



DVTR2800D Series

HIGH RELIABILITY HYBRID DC-DC CONVERTERS

DESCRIPTION

The DVTR series of high-reliability DC-DC converters provide decades of successful critical mission support. Operable over the full military (-55 °C to +125 °C) temperature range with no power derating, the DVTR series unique input, and output filters dramatically reduce input and output noise performance. While operating at a nominal fixed frequency of 475 kHz, these regulated, isolated units utilize a high-speed magnetic feedback design and well-controlled under-voltage lockout circuitry to eliminate slow start-up problems.

These converters are designed and manufactured in a facility qualified to ISO9001 and certified to MIL-PRF-38534 and MIL-STD-883.

This product may incorporate one or more of the following U.S. patents:

5,784,266
 5,790,389
 5,963,438
 5,999,433
 6,005,780
 6,084,792
 6,118,673

FEATURES

- High Reliability
- Very Low Output Noise
- Wide Input Voltage Range: 15 to 50 Volts per MIL-STD-704
- Up to 40 Watts Output Power
- Fault Tolerant Magnetic Feedback Circuit
- NO Use of Optoisolators
- Undervoltage Lockout
- Indefinite Short Circuit Protection
- Current Limit Protection
- Industry Standard Pinout
- High Input Transient Voltage: 80 Volts for 1 sec per MIL-STD-704A
- Precision Seam Welded Hermetic Package
- High Power Density: > 40 W/in³
- Custom Versions Available
- Additional Environmental Screening Available
- Meets MIL-STD-461 Revisions C, D, E and F EMC Requirements When Used With VPT's EMI Filters
- Flanged and Non-flanged Versions Available.
- MIL-PRF-38534 Element Evaluated Components
- Space Applications should consider VPT's "S" Series of Radiation Tolerant Power Conversion Devices. Contact VPT for details.

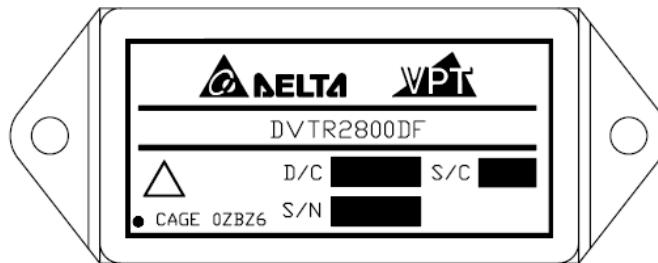

Figure 1 – DVTR2800D / DVTR2800DF DC-DC Converter
 (Exact marking may differ from that shown)

SPECIFICATIONS (T_{CASE} = -55°C to +125°C, V_{IN} = +28V ± 5%, Full Load⁵, Unless Otherwise Specified)

ABSOLUTE MAXIMUM RATINGS

Input Voltage (Continuous)	50 V _{DC}	Junction Temperature Rise to Case	+15°C
Input Voltage (Transient, 1 second)	80 Volts	Storage Temperature	-65°C to +150°C
Output Power ¹	40 Watts	Lead Solder Temperature (10 seconds)	270°C
Power Dissipation (Full Load, T _{CASE} = +125°C)	13 Watts	Weight (Maximum) (Un-Flanged / Flanged)	(52 / 55) Grams
ESD Rating per MIL-PRF-38534	3A		

Parameter	Conditions	DVTR2805D			DVTR2808D			Units	
		Min	Typ	Max	Min	Typ	Max		
STATIC									
INPUT Voltage ⁴	Continuous	15	28	50	15	28	50	V	
	Transient, 1 sec	-	-	80	-	-	80	V	
Current	Inhibited	-	4	6	-	4	6	mA	
	No Load	-	60	90	-	60	90	mA	
Ripple Current	Full Load ⁵ , 20Hz to 10MHz	-	30	50	-	30	50	mA _{p-p}	
Inhibit Pin Input ⁴		0	-	1.5	0	-	1.5	V	
Inhibit Pin Open Circuit Voltage ⁴		9.0	11.0	13.0	9.0	11.0	13.0	V	
UVLO Turn On		12.0	-	14.8	12.0	-	14.8	V	
UVLO Turn Off ⁴		11.0	-	14.5	11.0	-	14.5	V	
OUTPUT Voltage ⁵	+V _{OUT}	T _{CASE} = 25°C	4.95	5.0	5.05	7.92	8.0	8.08	V
	+V _{OUT}	T _{CASE} = -55°C to +125°C	4.925	5.0	5.075	7.88	8.0	8.12	V
	-V _{OUT}	T _{CASE} = 25°C	4.80	5.0	5.20	7.80	8.0	8.20	V
	-V _{OUT}	T _{CASE} = -55°C to +125°C	4.70	5.0	5.30	7.76	8.0	8.24	V
Power ^{3,6}	Total	0	-	30	0	-	35	W	
	±V _{OUT}	Either Output	0	-	21	0	-	25	W
Current ^{3,6}	±V _{OUT}	Either Output	0	-	4.2	0	-	3.12	A
Ripple Voltage	±V _{OUT}	Full Load ⁵ , 20Hz to 10MHz	-	30	60	-	40	60	mV _{p-p}
Line Regulation	+V _{OUT}	V _{IN} = 16V to 40V	-	2	20	-	2	20	mV
	-V _{OUT}	V _{IN} = 16V to 40V	-	25	200	-	35	200	mV
Load Regulation ^{5,7}	+V _{OUT}	No Load to Full Load	-	5	50	-	5	50	mV
	-V _{OUT}	No Load to Full Load	-	30	200	-	30	200	mV
Cross Regulation	-V _{OUT}	+Load 70%, -Load 30% +Load 30%, -Load 70%	-	360	650	-	450	650	mV
EFFICIENCY	Full Load ⁵	73	79	-	74	79	-	%	
LOAD FAULT POWER DISSIPATION	Overload ⁴	-	-	16	-	-	15	W	
	Short Circuit	-	-	16	-	-	15	W	
CAPACITIVE LOAD ⁴	Either Output	-	-	500	-	-	500	μF	
SWITCHING FREQUENCY		400	475	550	400	475	550	kHz	
SYNC FREQUENCY RANGE	V _H - V _L = 5V, DC = 20-80%	500	-	600	500	-	600	kHz	
ISOLATION	500 V _{DC} , T _{CASE} = 25°C	100	-	-	100	-	-	MΩ	
MTBF (MIL-HDBK-217F) ⁸	AIF @ T _C = 55°C	-	552	-	-	552	-	kHrs	

See notes next page.

SPECIFICATIONS (T_{CASE} = -55°C to +125°C, V_{IN} = +28V ± 5%, Full Load⁵, Unless Otherwise Specified)

ABSOLUTE MAXIMUM RATINGS

Input Voltage (Continuous)	50 V _{DC}	Junction Temperature Rise to Case	+15°C
Input Voltage (Transient, 1 second)	80 Volts	Storage Temperature	-65°C to +150°C
Output Power ¹	40 Watts	Lead Solder Temperature (10 seconds)	270°C
Power Dissipation (Full Load, T _{CASE} = +125°C)	13 Watts	Weight (Maximum) (Un-Flanged / Flanged)	(52 / 55) Grams
ESD Rating per MIL-PRF-38534	3A		

Parameter	Conditions	DVTR2805D			DVTR2808D			Units	
		Min	Typ	Max	Min	Typ	Max		
DYNAMIC									
Load Step Output Transient	±V _{OUT}	Half Load to Full Load	-	100	400	-	100	200	mV _{PK}
Load Step Recovery ²			-	100	350	-	50	100	μSec
Line Step Output Transient ⁴	±V _{OUT}	V _{IN} = 16V to 40V	-	300	600	-	200	550	mV _{PK}
Line Step Recovery ^{2, 4}			-	300	500	-	250	500	μSec
Turn On Delay	±V _{OUT}	V _{IN} = 0V to 28V	-	10	20	-	10	20	mSec
Turn On Overshoot			-	0	25	-	0	25	mV _{PK}

Notes:

1. Dependent on output voltage.
2. Time for output voltage to settle within 1% of its nominal value.
3. Derate linearly to 0 at 135°C.
4. Verified by initial electrical design verification. Post design verification, parameter shall be guaranteed to the limits specified.
5. Half load at +V_{OUT} and half load at -V_{OUT}.
6. Up to 70% of the total power or current can be drawn from any one of the two outputs.
7. 5% Load to Full Load at -55°C.
8. Correction factor of 0.12 added to ceramic capacitors.

SPECIFICATIONS (T_{CASE} = -55°C to +125°C, V_{IN} = +28V ± 5%, Full Load⁵, Unless Otherwise Specified)

ABSOLUTE MAXIMUM RATINGS

Input Voltage (Continuous)	50 V _{DC}	Junction Temperature Rise to Case	+15°C
Input Voltage (Transient, 1 second)	80 Volts	Storage Temperature	-65°C to +150°C
Output Power ¹	40 Watts	Lead Solder Temperature (10 seconds)	270°C
Power Dissipation (Full Load, T _{CASE} = +125°C)	13 Watts	Weight (Maximum) (Un-Flanged / Flanged)	(52 / 55) Grams
ESD Rating per MIL-PRF-38534	3A		

Parameter	Conditions	DVTR2812D			DVTR2815D			Units	
		Min	Typ	Max	Min	Typ	Max		
STATIC									
INPUT Voltage ⁴	Continuous	15	28	50	15	28	50	V	
	Transient, 1 sec	-	-	80	-	-	80	V	
Current	Inhibited	-	4	6	-	4	6	mA	
	No Load	-	60	90	-	60	90	mA	
Ripple Current	Full Load ⁵ , 20Hz to 10MHz	-	30	50	-	25	50	mA _{p-p}	
Inhibit Pin Input ⁴		0	-	1.5	0	-	1.5	V	
Inhibit Pin Open Circuit Voltage ⁴		9.0	11.0	13.0	9.0	11.0	13.0	V	
UVLO Turn On		12.0	-	14.8	12.0	-	14.8	V	
UVLO Turn Off ⁴		11.0	-	14.5	11.0	-	14.5	V	
OUTPUT Voltage ⁵	+V _{OUT}	T _{CASE} = 25°C	11.88	12.0	12.12	14.85	15.0	15.15	V
	+V _{OUT}	T _{CASE} = -55°C to +125°C	11.82	12.0	12.18	14.70	15.0	15.30	V
	-V _{OUT}	T _{CASE} = 25°C	11.80	12.0	12.20	14.70	15.0	15.30	V
	-V _{OUT}	T _{CASE} = -55°C to +125°C	11.64	12.0	12.36	14.55	15.0	15.45	V
Power ^{3,6}	Total		0	-	40	0	-	40	W
	±V _{OUT}	Either Output	0	-	28	0	-	28	W
Current ^{3,6}	±V _{OUT}	Either Output	0	-	2.33	0	-	1.87	A
Ripple Voltage	±V _{OUT}	Full Load ⁵ , 20Hz to 10MHz	-	25	50	-	25	50	mV _{p-p}
Line Regulation	+V _{OUT}	V _{IN} = 16V to 40V	-	2	20	-	2	20	mV
	-V _{OUT}	V _{IN} = 16V to 40V	-	25	200	-	65	200	mV
Load Regulation ^{5,7}	+V _{OUT}	No Load to Full Load	-	2	50	-	2	50	mV
	-V _{OUT}	No Load to Full Load	-	20	200	-	35	200	mV
Cross Regulation	-V _{OUT}	+Load 70%, -Load 30% +Load 30%, -Load 70%	-	430	650	-	420	650	mV
EFFICIENCY		Full Load ⁵	78	84	-	78	84	-	%
LOAD FAULT POWER DISSIPATION	Overload ⁴		-	-	14	-	-	14	W
	Short Circuit		-	-	14	-	-	14	W
CAPACITIVE LOAD ⁴		Either Output	-	-	500	-	-	500	μF
SWITCHING FREQUENCY			400	475	550	400	475	550	kHz
SYNC FREQUENCY RANGE		V _H - V _L = 5V, DC = 20-80%	500	-	600	500	-	600	kHz
ISOLATION		500 V _{DC} , T _{CASE} = 25°C	100	-	-	100	-	-	MΩ
MTBF (MIL-HDBK-217F) ⁸		AIF @ T _C = 55°C	-	552	-	-	552	-	kHrs

See notes next page.

SPECIFICATIONS (T_{CASE} = -55°C to +125°C, V_{IN} = +28V ± 5%, Full Load⁵, Unless Otherwise Specified)

ABSOLUTE MAXIMUM RATINGS

Input Voltage (Continuous)	50 V _{DC}	Junction Temperature Rise to Case	+15°C
Input Voltage (Transient, 1 second)	80 Volts	Storage Temperature	-65°C to +150°C
Output Power ¹	40 Watts	Lead Solder Temperature (10 seconds)	270°C
Power Dissipation (Full Load, T _{CASE} = +125°C)	13 Watts	Weight (Maximum) (Un-Flanged / Flanged)	(52 / 55) Grams
ESD Rating per MIL-PRF-38534	3A		

Parameter	Conditions	DVTR2812D			DVTR2815D			Units	
		Min	Typ	Max	Min	Typ	Max		
DYNAMIC									
Load Step Output Transient	±V _{OUT}	Half Load to Full Load	-	300	450	-	280	500	mV _{PK}
Load Step Recovery ²			-	120	400	-	100	300	μSec
Line Step Output Transient ⁴	±V _{OUT}	V _{IN} = 16V to 40V P _{OUT} = 30W	-	500	900	-	500	900	mV _{PK}
Line Step Recovery ^{2, 4}			-	300	500	-	300	500	μSec
Turn On Delay	±V _{OUT}	V _{IN} = 0V to 28V	-	10	20	-	10	20	mSec
Turn On Overshoot			-	0	50	-	0	50	mV _{PK}

Notes:

1. Dependent on output voltage.
2. Time for output voltage to settle within 1% of its nominal value.
3. Derate linearly to 0 at 135°C.
4. Verified by initial electrical design verification. Post design verification, parameter shall be guaranteed to the limits specified.
5. Half load at +V_{OUT} and half load at -V_{OUT}.
6. Up to 70% of the total power or current can be drawn from any one of the two outputs.
7. 5% Load to Full Load at -55°C.
8. Correction factor of 0.12 added to ceramic capacitors.

SPECIFICATIONS (T_{CASE} = -55°C to +125°C, V_{IN} = +28V ± 5%, Full Load⁵, Unless Otherwise Specified)

ABSOLUTE MAXIMUM RATINGS

Input Voltage (Continuous)	50 V _{DC}	Junction Temperature Rise to Case	+15°C
Input Voltage (Transient, 1 second)	80 Volts	Storage Temperature	-65°C to +150°C
Output Power ¹	40 Watts	Lead Solder Temperature (10 seconds)	270°C
Power Dissipation (Full Load, T _{CASE} = +125°C)	13 Watts	Weight (Maximum) (Un-Flanged / Flanged)	(52 / 55) Grams
ESD Rating per MIL-PRF-38534	3A		

Parameter	Conditions	DVTR2815R7D			DVTR2818D			Units	
		Min	Typ	Max	Min	Typ	Max		
STATIC									
INPUT Voltage ⁴	Continuous	15	28	50	15	28	50	V	
	Transient, 1 sec	-	-	80	-	-	80	V	
Current	Inhibited	-	4	6	-	4	6	mA	
	No Load	-	60	90	-	60	90	mA	
Ripple Current	Full Load ⁵ , 20Hz to 10MHz	-	25	50	-	30	50	mA _{p-p}	
Inhibit Pin Input ⁴		0	-	1.5	0	-	1.5	V	
Inhibit Pin Open Circuit Voltage ⁴		9.0	11.0	13.0	9.0	11.0	13.0	V	
UVLO Turn On		12.0	-	14.8	12.0	-	14.8	V	
UVLO Turn Off ⁴		11.0	-	14.5	11.0	-	14.5	V	
OUTPUT Voltage ⁵	+V _{OUT}	T _{CASE} = 25°C	15.54	15.7	15.86	17.82	18.0	18.18	V
	+V _{OUT}	T _{CASE} = -55°C to +125°C	15.38	15.7	16.01	17.64	18.0	18.36	V
	-V _{OUT}	T _{CASE} = 25°C	15.38	15.7	16.01	17.64	18.0	18.36	V
	-V _{OUT}	T _{CASE} = -55°C to +125°C	15.23	15.7	16.17	17.46	18.0	18.54	V
Power ^{3,6}	Total	0	-	40	-	-	40	W	
	±V _{OUT}	Either Output	0	-	28	-	-	28	W
Current ^{3,6}	±V _{OUT}	Either Output	0	-	1.78	-	-	1.56	A
Ripple Voltage	±V _{OUT}	Full Load ⁵ , 20Hz to 10MHz	-	25	50	-	25	50	mV _{p-p}
Line Regulation	+V _{OUT}	V _{IN} = 16V to 40V	-	2	20	-	2	20	mV
	-V _{OUT}	V _{IN} = 16V to 40V	-	65	200	-	80	200	mV
Load Regulation ^{5,7}	+V _{OUT}	No Load to Full Load	-	2	50	-	2	50	mV
	-V _{OUT}	No Load to Full Load	-	35	200	-	45	200	mV
Cross Regulation	-V _{OUT}	+Load 70%, -Load 30% +Load 30%, -Load 70%	-	420	650	-	420	650	mV
EFFICIENCY	Full Load ⁵	78	84	-	78	83	-	%	
LOAD FAULT POWER DISSIPATION	Overload ⁴	-	-	14	-	-	14	W	
	Short Circuit	-	-	14	-	-	14	W	
CAPACITIVE LOAD ⁴	Either Output	-	-	500	-	-	300	μF	
SWITCHING FREQUENCY		400	475	550	400	475	550	kHz	
SYNC FREQUENCY RANGE	V _H - V _L = 5V, DC = 20-80%	500	-	600	500	-	600	kHz	
ISOLATION	500 V _{DC} , T _{CASE} = 25°C	100	-	-	100	-	-	MΩ	
MTBF (MIL-HDBK-217F) ⁸	AIF @ T _C = 55°C	-	552	-	-	552	-	kHrs	

See notes next page.

SPECIFICATIONS (T_{CASE} = -55°C to +125°C, V_{IN} = +28V ± 5%, Full Load⁵, Unless Otherwise Specified)

ABSOLUTE MAXIMUM RATINGS

Input Voltage (Continuous)	50 V _{DC}	Junction Temperature Rise to Case	+15°C
Input Voltage (Transient, 1 second)	80 Volts	Storage Temperature	-65°C to +150°C
Output Power ¹	40 Watts	Lead Solder Temperature (10 seconds)	270°C
Power Dissipation (Full Load, T _{CASE} = +125°C)	13 Watts	Weight (Maximum) (Un-Flanged / Flanged)	(52 / 55) Grams
ESD Rating per MIL-PRF-38534	3A		

Parameter	Conditions	DVTR2815R7D			DVTR2818D			Units	
		Min	Typ	Max	Min	Typ	Max		
DYNAMIC									
Load Step Output Transient	±V _{OUT}	Half Load to Full Load	-	280	500	-	250	500	mV _{PK}
Load Step Recovery ²			-	100	300	-	100	250	μSec
Line Step Output Transient ⁴	±V _{OUT}	V _{IN} = 16V to 40V	-	700	1200	-	1200	2200	mV _{PK}
Line Step Recovery ^{2, 4}		P _{OUT} = 30W	-	300	500	-	350	500	μSec
Turn On Delay	±V _{OUT}	V _{IN} = 0V to 28V	-	10	20	-	10	20	mSec
Turn On Overshoot			-	0	50	-	0	50	mV _{PK}

Notes:

1. Dependent on output voltage.
2. Time for output voltage to settle within 1% of its nominal value.
3. Derate linearly to 0 at 135°C.
4. Verified by initial electrical design verification. Post design verification, parameter shall be guaranteed to the limits specified.
5. Half load at +V_{OUT} and half load at -V_{OUT}.
6. Up to 70% of the total power or current can be drawn from any one of the two outputs.
7. 5% Load to Full Load at -55°C.
8. Correction factor of 0.12 added to ceramic capacitors.

BLOCK DIAGRAM

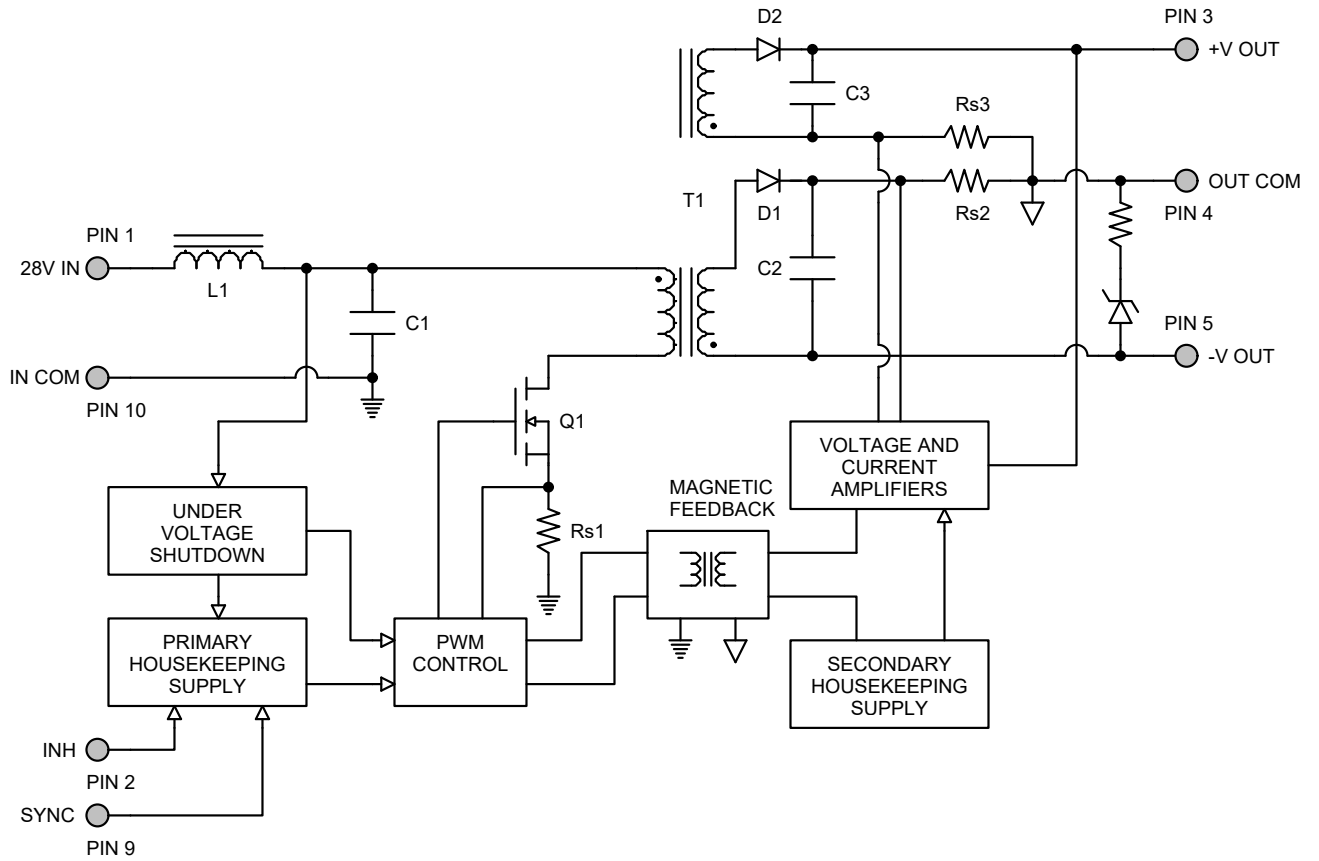

Figure 2

CONNECTION DIAGRAM

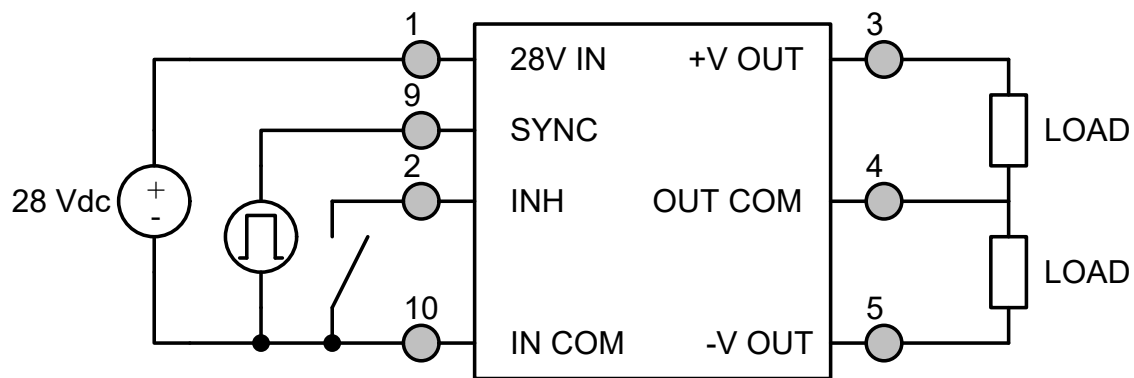

Figure 3

INHIBIT DRIVE CONNECTION DIAGRAMS

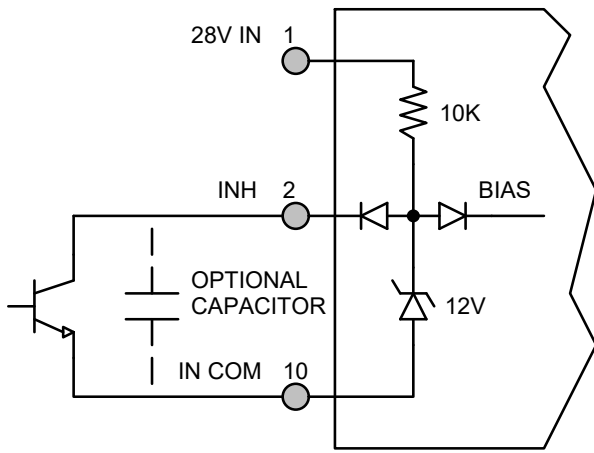

Figure 4 – Internal Inhibit Circuit and Recommended Drive
(Shown with optional capacitor for turn-on delay)

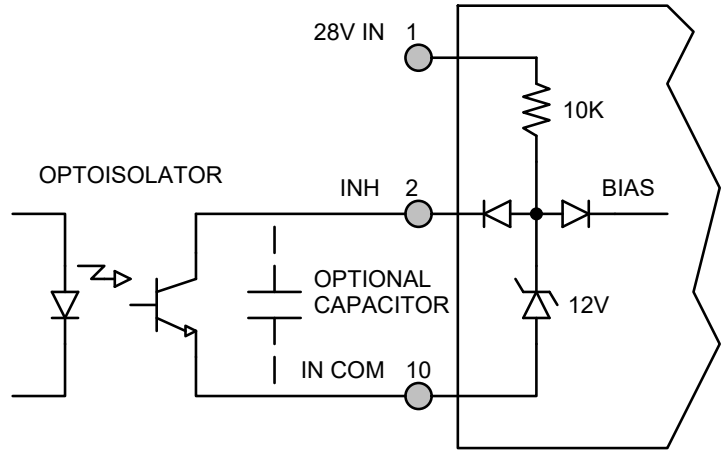

Figure 5 – Isolated Inhibit Drive
(Shown with optional capacitor for turn-on delay)

EMI FILTER HOOKUP DIAGRAM

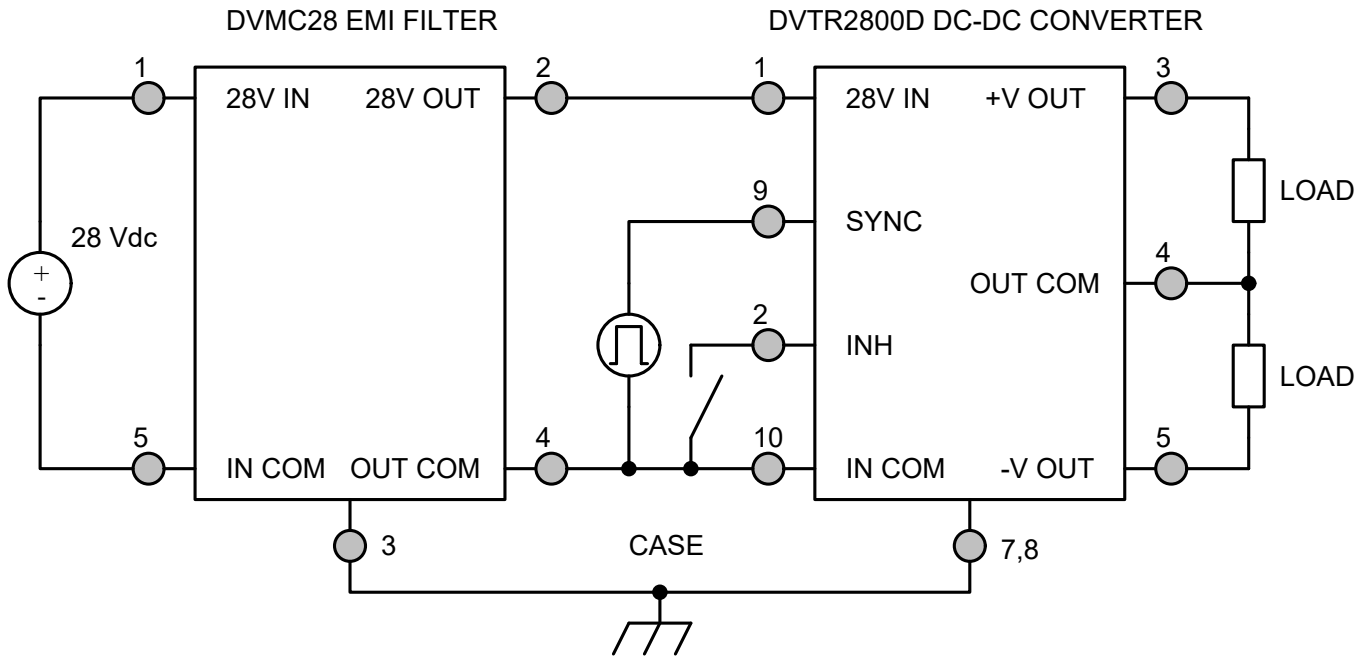

Figure 6 – Converter with EMI Filter

EFFICIENCY PERFORMANCE CURVES ($T_{CASE} = 25^{\circ}C$, Full Load, Unless Otherwise Specified)

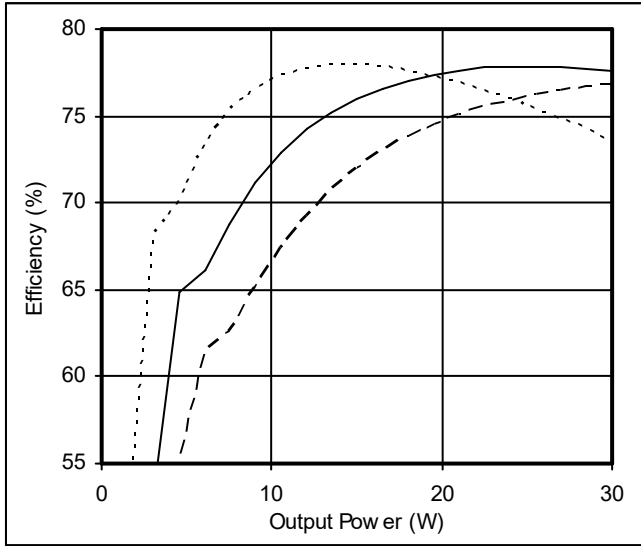
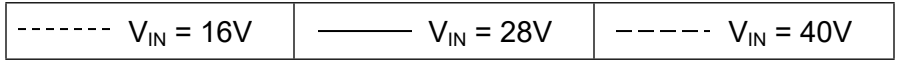

Figure 7 – DVTR2805D
Efficiency (%) vs. Output Power (W)

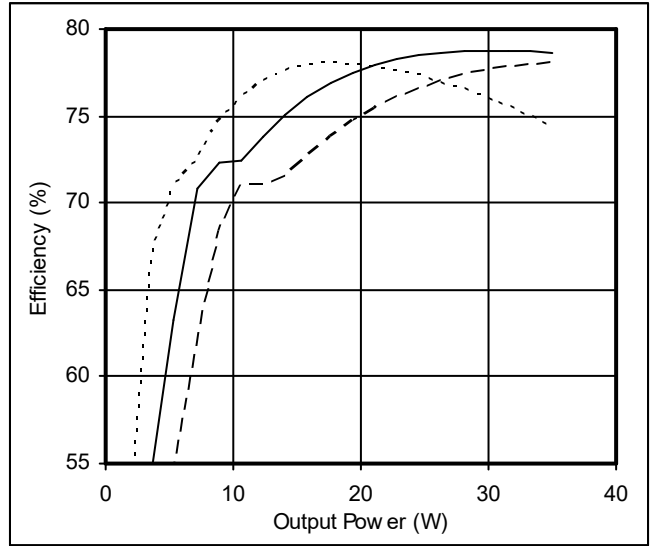

Figure 8 – DVTR2808D
Efficiency (%) vs. Output Power (W)

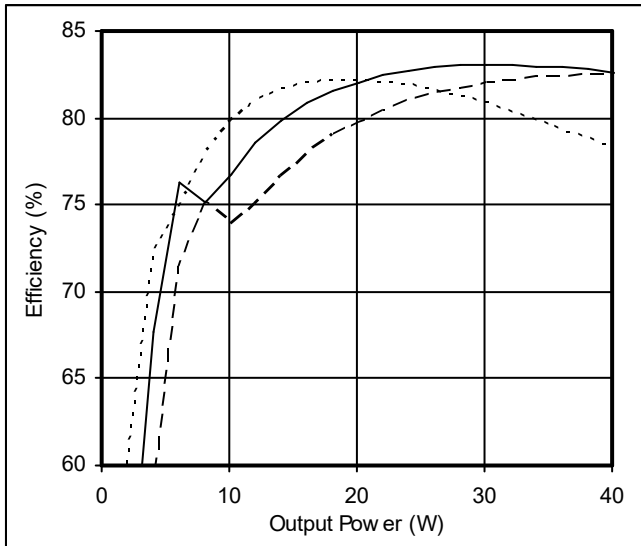

Figure 9 – DVTR2812D
Efficiency (%) vs. Output Power (W)

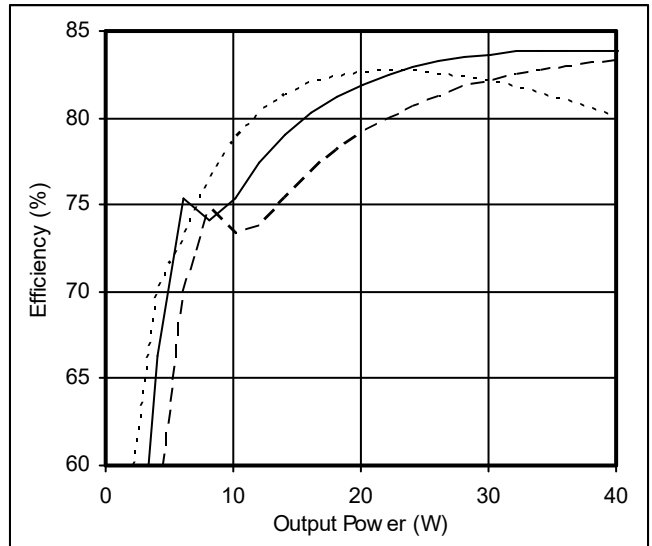

Figure 10 – DVTR2815D
Efficiency (%) vs. Output Power (W)

EFFICIENCY PERFORMANCE CURVES ($T_{CASE} = 25^{\circ}C$, Full Load, Unless Otherwise Specified)

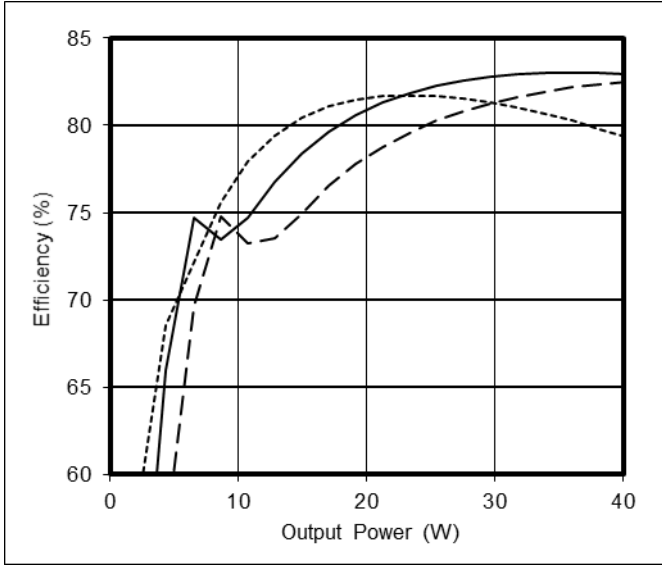
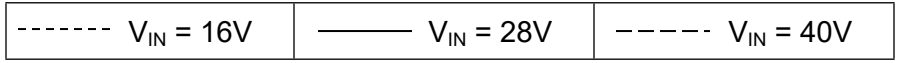

Figure 11 – DVTR2815R7D
Efficiency (%) vs. Output Power (W)

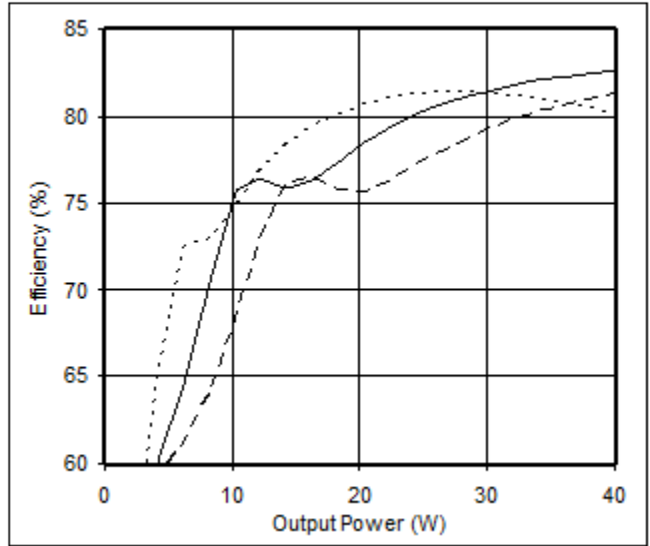

Figure 12 – DVTR2818D
Efficiency (%) vs. Output Power (W)

CROSS REGULATION CURVES ($T_{CASE} = 25^{\circ}C$, Full Load, Unless Otherwise Specified)

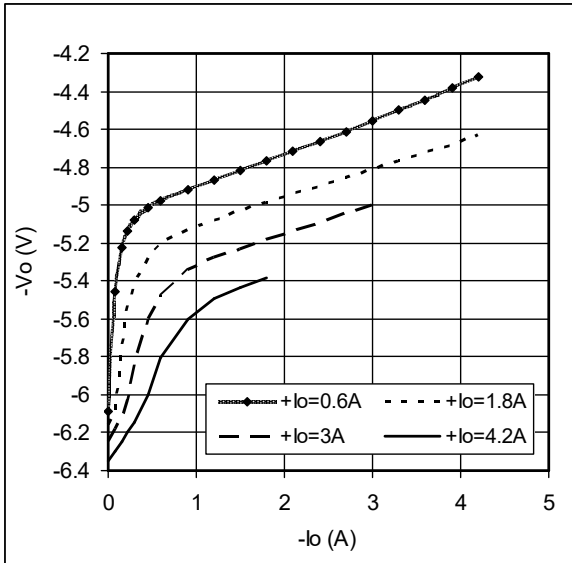
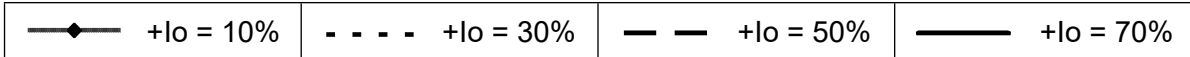

Figure 12 – DVTR2805D
-Vout (V) vs. -Iout (A)

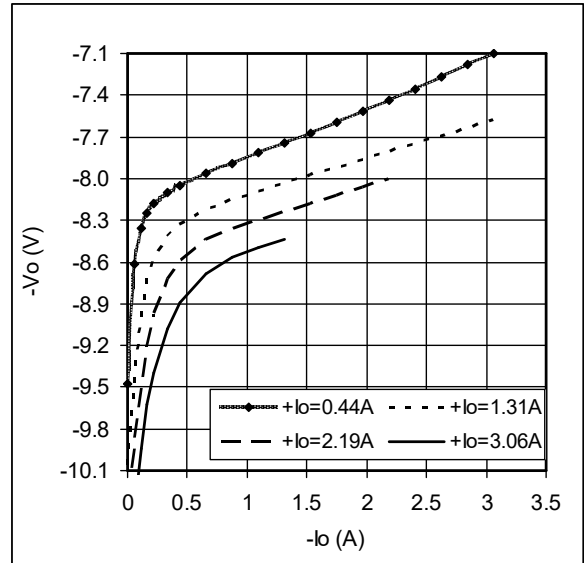

Figure 13 – DVTR2808D
-Vout (V) vs. -Iout (A)

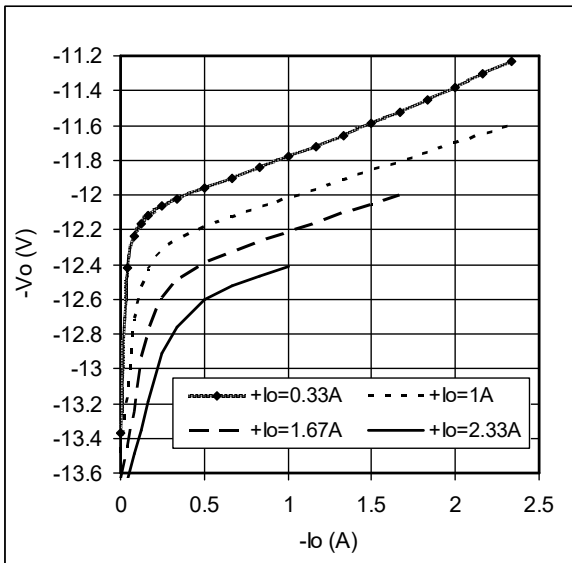

Figure 14 – DVTR2812D
-Vout (V) vs. -Iout (A)

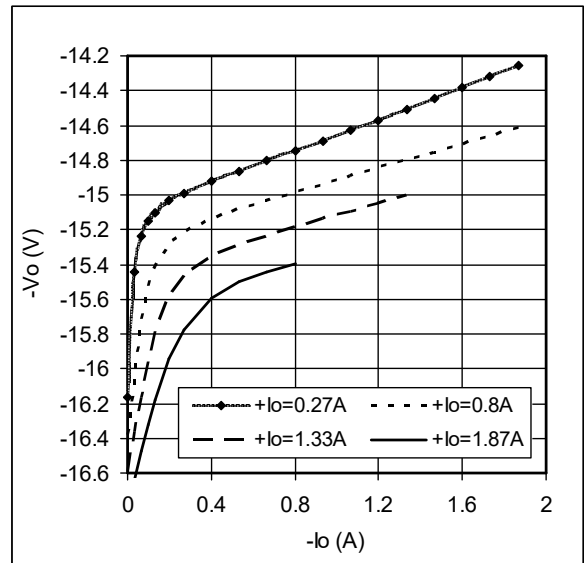

Figure 15 – DVTR2815D
-Vout (V) vs. -Iout (A)

CROSS REGULATION CURVES ($T_{CASE} = 25^{\circ}C$, Full Load, Unless Otherwise Specified)

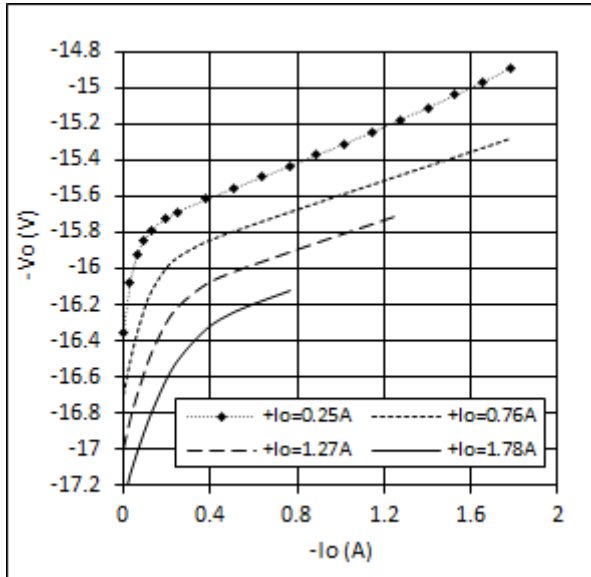
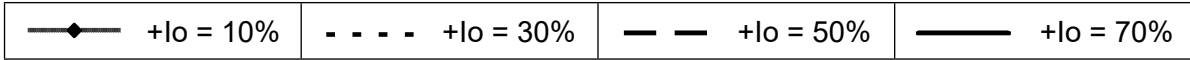

Figure 17 – DVTR2815R7D
-Vout (V) vs. -Iout (A)

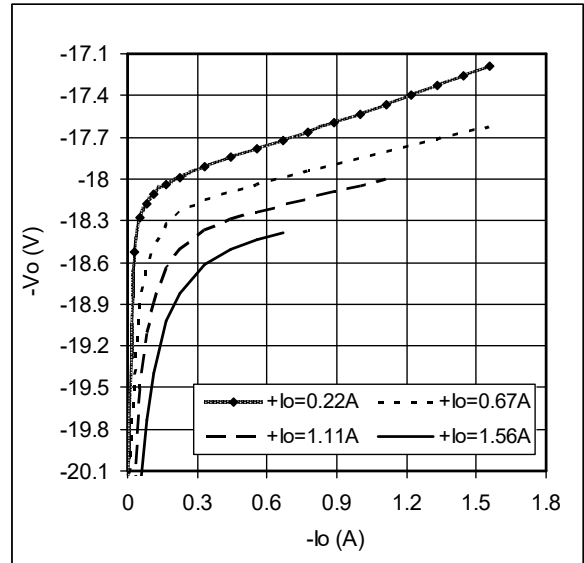

Figure 18 – DVTR2818D
-Vout (V) vs. -Iout (A)

EMI PERFORMANCE CURVES

($T_{CASE} = 25^{\circ}C$, $V_{IN} = +28V \pm 5\%$, Full Load, Unless Otherwise Specified)

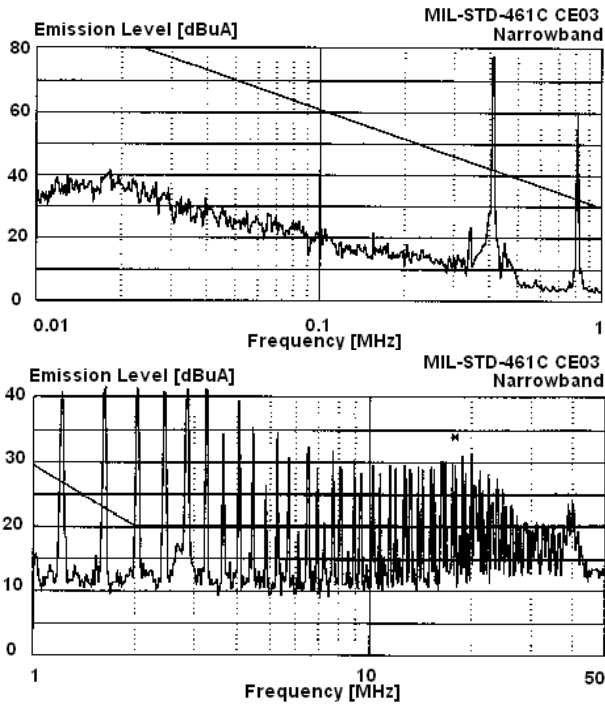

Figure 17 – DVTR2800D without EMI Filter

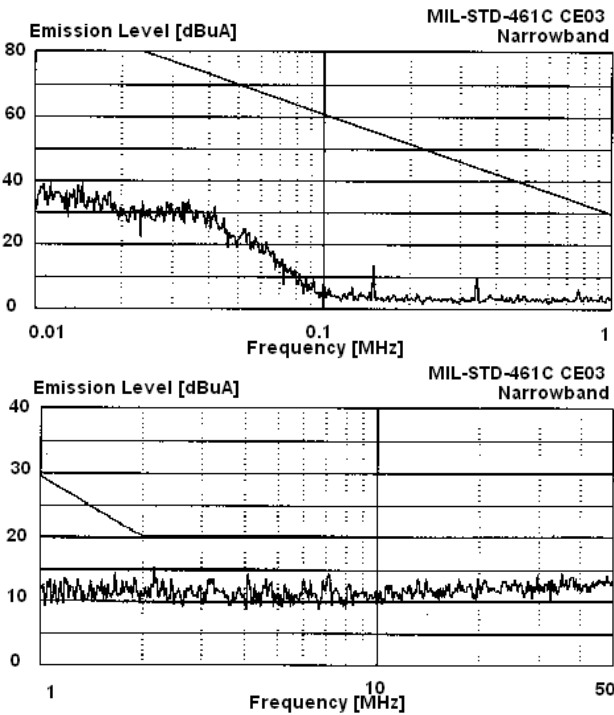
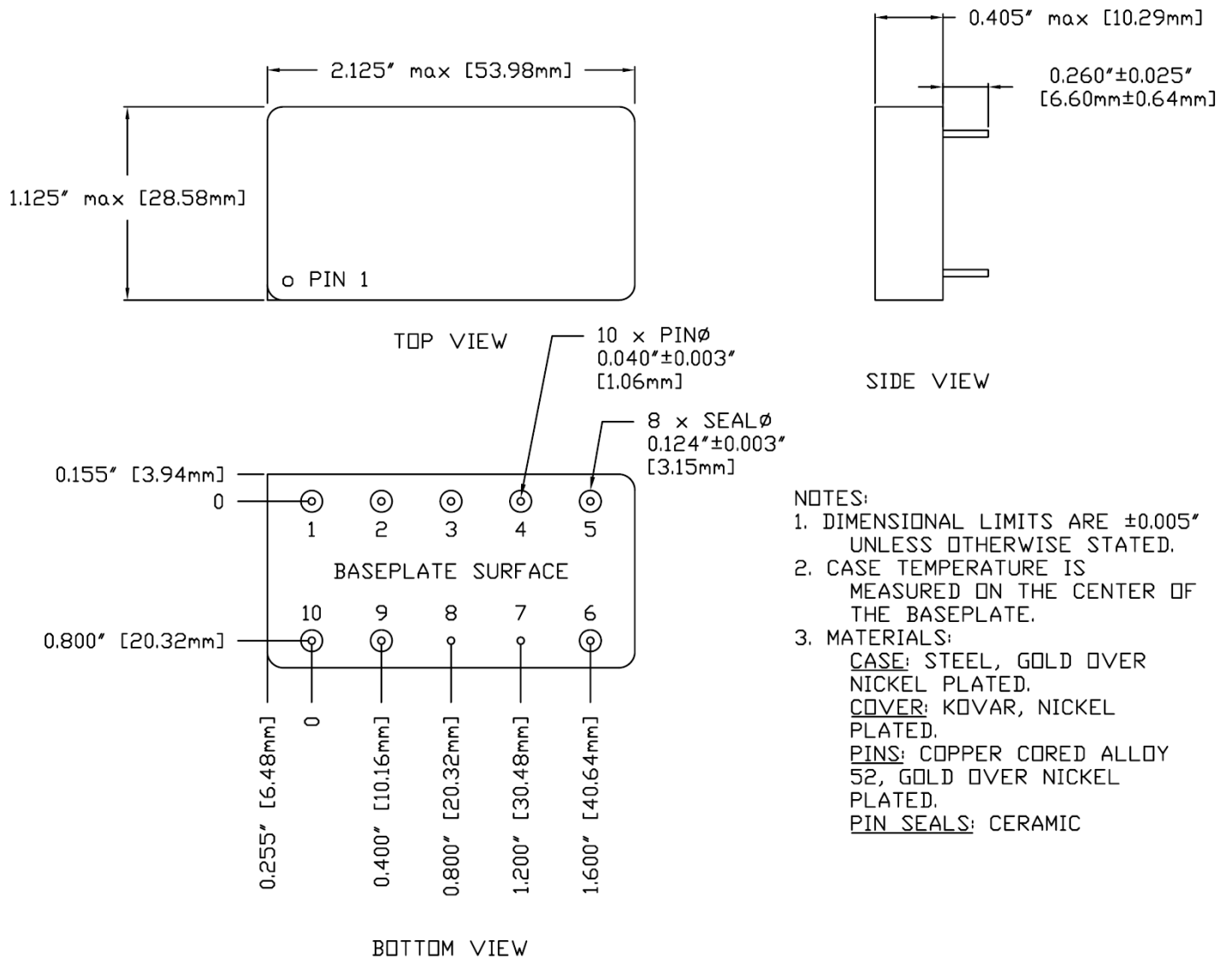

Figure 18 – DVTR2800D with EMI Filter

PACKAGE SPECIFICATIONS (NON-FLANGED)



Pin	Function	Pin	Function
1	28V IN	6	CASE
2	INHIBIT	7	CASE
3	+V OUT	8	CASE
4	OUT COM	9	SYNC
5	-V OUT	10	IN COM

Figure 19 – Non-Flanged, Seam Seal Package and Pinout

PACKAGE SPECIFICATIONS (FLANGED)

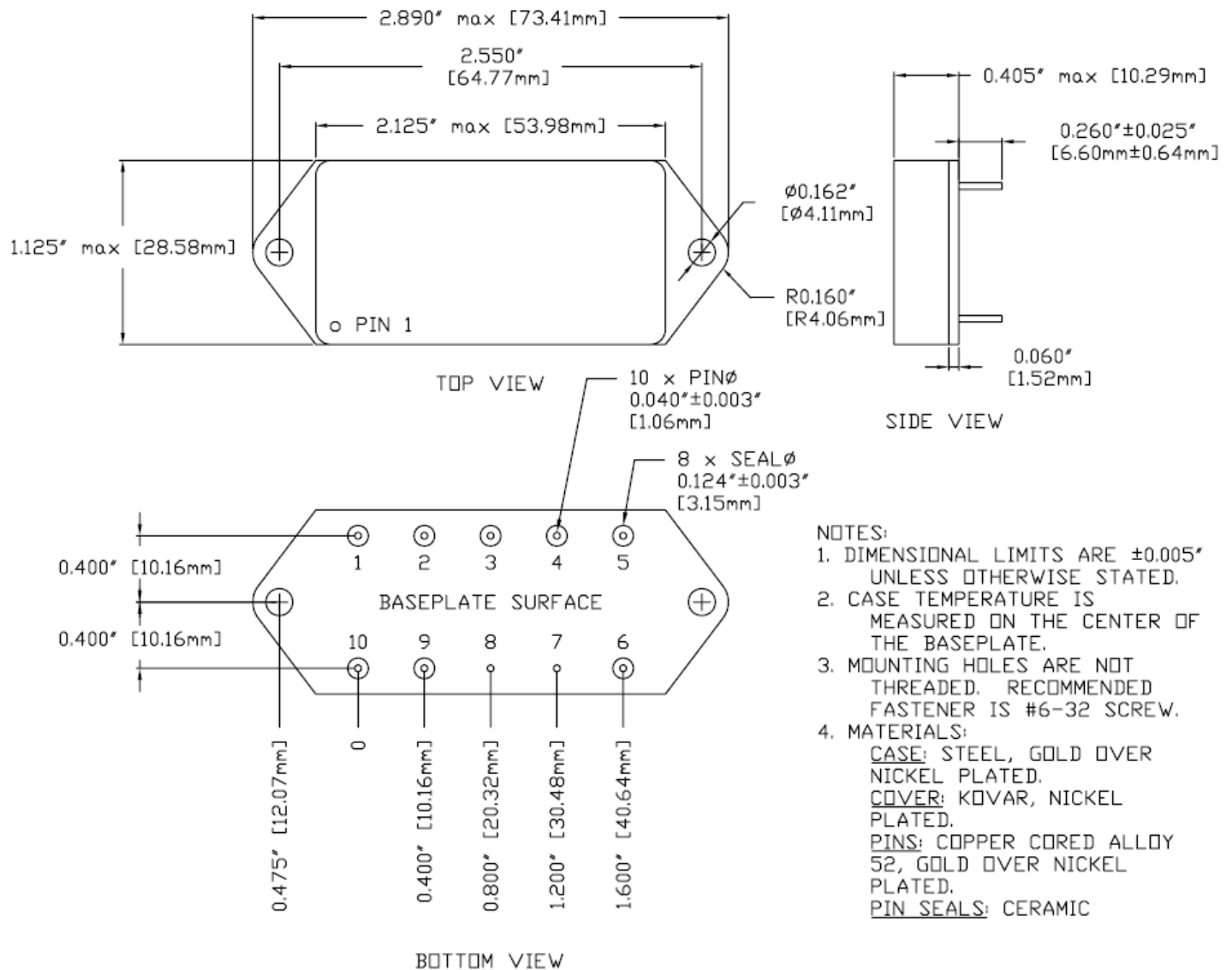

Pin	Function	Pin	Function
1	28V IN	6	CASE
2	INHIBIT	7	CASE
3	+V OUT	8	CASE
4	OUT COM	9	SYNC
5	-V OUT	10	IN COM

Figure 20 – Flanged, Seam Seal Package and Pinout

PACKAGE PIN DESCRIPTION

Pin	Function	Description
1	28V IN	Positive Input Voltage Connection
2	INHIBIT	Logic Low = Disabled Output. Connecting the inhibit pin to input common causes converter shutdown. Logic High = Enabled Output. Unconnected or open collector TTL.
3	+V OUT	Positive Output Voltage Connection
4	OUT COM	Output Common Connection
5	-V OUT	Negative Output Voltage Connection
6	CASE	Case Connection
7	CASE	Case Connection
8	CASE	Case Connection
9	SYNC	Synchronization Signal
10	IN COM	Input Common Connection

ENVIRONMENTAL SCREENING (100% Tested Per MIL-STD-883 as referenced to MIL-PRF-38534)

Test	MIL-STD-883 Test Method, Condition	No Suffix (Standard) Non-QML 5	/ES (Extended) Non-QML 5	/H (Class H)	/KL1 Non-QML 5,9
Non-Destructive Bond Pull	TM2023	• ⁴	• ⁴	• ⁴	•
Internal Visual	TM2010, TM2017, TM2032 (MIL-STD-750, TM2072, TM2073)	•	•	•	•
Temperature Cycling	TM1010, Condition C -65°C to 150°C, Ambient			•	•
	TM1010, Condition B -55°C to 125°C, Ambient		•		
Constant Acceleration	TM2001, 3000g, Y1 Direction			•	•
	TM2001, 500g, Y1 Direction		•		
PIND ⁷	TM2020, Condition A				•
Pre Burn-In Electrical	25°C				•
Burn-In	TM1015, 320 hrs, 125°C, Case Typ				•
	TM1015, 160 hrs, 125°C, Case Typ			•	
	96 hrs, 125°C, Case Typ		•		
	24 hrs, 125°C, Case Typ	•			
Final Electrical	MIL-PRF-38534, Group A Subgroups 1-6 -55°C, 25°C, 125°C ³			•	•
	MIL-PRF-38534, Group A Subgroups 1 and 4 25°C	•	•		
Hermeticity (Seal)	TM1014, Fine Leak, Condition A2 or B1		•	•	•
	TM1014, Gross Leak, Condition C1 or B2		•	•	•
	Gross Leak, Dip (No Bomb), Visual Verification	•			
Radiography ⁸	TM2012				•
External Visual	TM2009	•	•	•	•

- Notes:
- Contact Sales for more information concerning additional environmental screening and testing options desired.
 - VPT Inc. reserves the right to ship higher screened or SMD products to meet lower screened orders at our sole discretion unless specifically forbidden by customer contract.
 - 100% R&R testing with all test data included in product shipment.
 - Not required per MIL-PRF-38534. Test is performed for additional product quality assurance.
 - Non-QML products may not meet all requirements of MIL-PRF-38534.
 - Note intentionally not used.
 - PIND test Certificate of Compliance included in product shipment.
 - Radiographic test Certificate of Compliance and film(s) or data CD included in product shipment.
 - KL1 products are identical in every way with Class K products in compliance with MIL-PRF-38534 revision L and later revisions except they contain elements evaluated to the requirements of MIL-PRF-38534 revision K and previous revisions. These devices are not marked with an SMD number or MIL-PRF-38534 certification mark and are marked with -KL1 screening code in place of -K.

ORDERING INFORMATION

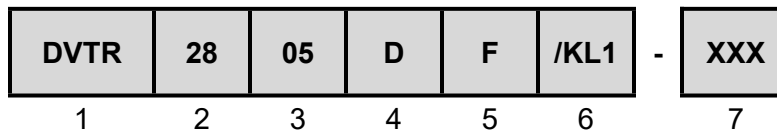

(1) Product Series	(2) Nominal Input Voltage		(3) Output Voltage		(4) Number of Outputs	
DVTR	28	28 Volts	05 08 12 15 15R7 18	± 5 Volts ± 8 Volts ± 12 Volts ± 15 Volts ± 15.7 Volts ± 18 Volts	D	Dual

(5) Package Option		(6) Screening Code ^{1,2,3}		(7) Additional Screening Code
None F	Non-Flanged Flanged	None /ES /H /KL1	Standard Extended Class H Class KL1	Contact Sales

- Notes:
1. Contact the VPT Sales Department for availability of Class H (/H) and KL1 (/KL1) qualified products.
 2. VPT Inc. reserves the right to ship higher screened or SMD products to meet lower screened orders at our sole discretion unless specifically forbidden by customer contract.
 3. -KL1 products are identical in every way with Class K products in compliance with MIL-PRF-38534 revision L and later revisions except they contain elements evaluated to the requirements of MIL-PRF-38534 revision K and previous revisions. These devices are not marked with an SMD number or MIL-PRF-38534 certification mark and are marked with -KL1 screening code in place of -K.

Please contact your sales representative or the VPT Inc. Sales Department for more information concerning additional environmental screening and testing, different input voltage, output voltage, power requirement, source inspection, and/or special element evaluation for space or other higher quality applications.

SMD (STANDARD MICROCIRCUIT DRAWING) NUMBERS

Standard Microcircuit Drawing (SMD)	Vendor Cage Code	DVTR2800S Series Similar Part Number
5962-1122501HXC	0ZBZ6	DVTR2805D/H
5962-1122501HXA	0ZBZ6	DVTR2805D/H-E
5962-1122501HYC	0ZBZ6	DVTR2805DF/H
5962-1122501HYA	0ZBZ6	DVTR2805DF/H-E
5962-1122502HXC	0ZBZ6	DVTR2812D/H
5962-1122502HXA	0ZBZ6	DVTR2812D/H-E
5962-1122502HYC	0ZBZ6	DVTR2812DF/H
5962-1122502HYA	0ZBZ6	DVTR2812DF/H-E
5962-1122503HXC	0ZBZ6	DVTR2815D/H
5962-1122503HXA	0ZBZ6	DVTR2815D/H-E
5962-1122503HYC	0ZBZ6	DVTR2815DF/H
5962-1122503HYA	0ZBZ6	DVTR2815DF/H-E
5962-1122504HXC	0ZBZ6	DVTR2808D/H
5962-1122504HXA	0ZBZ6	DVTR2808D/H-E
5962-1122504HYC	0ZBZ6	DVTR2808DF/H
5962-1122504HYA	0ZBZ6	DVTR2808DF/H-E
5962-1122505HXC	0ZBZ6	DVTR2818D/H
5962-1122505HXA	0ZBZ6	DVTR2818D/H-E
5962-1122505HYC	0ZBZ6	DVTR2818DF/H
5962-1122505HYA	0ZBZ6	DVTR2818DF/H-E

Do not use the DVTR2800D Series similar part number for SMD product acquisition. It is listed for reference only. For exact specifications for the SMD product, refer to the SMD drawing. SMDs can be downloaded from the DLA Land and Maritime (Previously known as DSCC) website at <https://landandmaritimeapps.dla.mil/programs/defaultapps.asp>. The SMD number listed above represents the Federal Stock Class, Device Type, Device Class Designator, Case Outline, Lead Finish and RHA Designator (where applicable). Please reference the SMD for other screening levels, lead finishes, and radiation levels. All SMD products are marked with a "Q" on the cover as specified by the QML certification mark requirement of MIL-PRF-38534.

CONTACT INFORMATION

To request a quotation or place an order please contact your sales representative or the VPT Inc. Sales Department at:

Phone: (425) 353-3010
Fax: (425) 353-4030
E-mail: vptsales@vptpower.com

All information contained in this datasheet is believed to be accurate, however, no responsibility is assumed for possible errors or omissions. The products or specifications contained herein are subject to change without notice.