

## HIGH RELIABILITY HYBRID DC-DC CONVERTERS

### DESCRIPTION

The DVTR series of high-reliability DC-DC converters provide decades of successful critical mission support. Operable over the full military (-55 °C to +125 °C) temperature range with no power derating, the DVTR series unique input, and output filters dramatically reduce input and output noise performance. While operating at a nominal fixed frequency of 475 kHz, these regulated, isolated units utilize a high-speed magnetic feedback design and well-controlled under-voltage lockout circuitry to eliminate slow start-up problems.

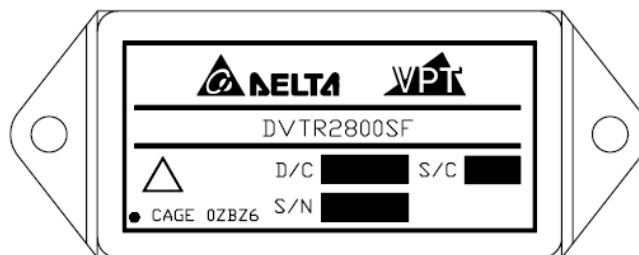
These converters are designed and manufactured in a facility qualified to ISO9001 and certified to MIL-PRF-38534 and MIL-STD-883.

This product may incorporate one or more of the following U.S. patents:

5,784,266  
5,790,389  
5,963,438  
5,999,433  
6,005,780  
6,084,792  
6,118,673

### FEATURES

- High Reliability
- Very Low Output Noise
- Wide Input Voltage Range: 15 to 50 Volts per MIL-STD-704
- Up to 40 Watts Output Power
- Fault Tolerant Magnetic Feedback Circuit
- Output Voltage Trim Up +10%
- NO Use of Optoisolators
- Undervoltage Lockout
- Indefinite Short Circuit Protection
- Current Limit Protection
- Industry Standard Pinout
- High Input Transient Voltage: 80 Volts for 1 sec per MIL-STD-704A
- Precision Seam Seal Hermetic Package
- High Power Density: > 40 W/in<sup>3</sup>
- Custom Versions Available
- Additional Environmental Screening Available
- Meets MIL-STD-461 Revisions C, D, E and F EMC Requirements When Used With VPT's EMI Filters
- Flanged and Non-flanged Versions Available
- MIL-PRF-38534 Element Evaluated Components
- Space Applications should consider VPT's "S" Series of Radiation Tolerant Power Conversion Devices. Contact VPT for details.



**Figure 1** – DVTR2800S / DVTR2800SF DC-DC Converter  
(Exact marking may differ from that shown)

## SPECIFICATIONS (T<sub>CASE</sub> = -55°C to +125°C, V<sub>IN</sub> = +28V ± 5%, Full Load, Unless Otherwise Specified)

### ABSOLUTE MAXIMUM RATINGS

Input Voltage (Continuous)	50 V <sub>DC</sub>	Junction Temperature Rise to Case	+15°C
Input Voltage (Transient, 1 second)	80 Volts	Storage Temperature	-65°C to +150°C
Output Power <sup>1</sup>	40 Watts	Lead Solder Temperature (10 seconds)	270°C
Power Dissipation (Full Load, T <sub>CASE</sub> = +125°C)	13 Watts	Weight (Maximum) (Un-Flanged / Flanged)	(52 / 55) Grams
ESD Rating per MIL-PRF-38534	3A		

Parameter	Conditions	DVTR282R5S			DVTR283R3S			Units	
		Min	Typ	Max	Min	Typ	Max		
<b>STATIC</b>									
INPUT Voltage <sup>4</sup>	Continuous	15	28	50	15	28	50	V	
	Transient, 1 sec	-	-	80	-	-	80	V	
Current	Inhibited	-	4	6	-	4	6	mA	
	No Load	-	50	90	-	50	90	mA	
Ripple Current	Full Load, 20Hz to 10MHz	-	15	50	-	20	50	mA <sub>p-p</sub>	
Inhibit Pin Input <sup>4</sup>		0	-	1.5	0	-	1.5	V	
Inhibit Pin Open Circuit Voltage <sup>4</sup>		9.0	11.0	13.0	9.0	11.0	13.0	V	
UVLO Turn On		12.0	-	14.8	12.0	-	14.8	V	
UVLO Turn Off <sup>4</sup>		11.0	-	14.5	11.0	-	14.5	V	
OUTPUT Voltage	V <sub>OUT</sub> T <sub>CASE</sub> = 25°C	2.47	2.5	2.53	3.25	3.3	3.35	V	
	V <sub>OUT</sub> T <sub>CASE</sub> = -55°C to +125°C	2.46	2.5	2.54	3.2	3.3	3.4	V	
Power <sup>3</sup>		0	-	15	0	-	20	W	
Current <sup>3</sup>	V <sub>OUT</sub>	0	-	6.0	0	-	6.06	A	
Ripple Voltage	V <sub>OUT</sub> Full Load, 20Hz to 10MHz	-	20	50	-	25	50	mV <sub>p-p</sub>	
Line Regulation	V <sub>OUT</sub> V <sub>IN</sub> = 15V to 50V	-	2	20	-	2	20	mV	
Load Regulation	V <sub>OUT</sub> No Load to Full Load	-	2	50	-	2	50	mV	
EFFICIENCY		63	66	-	65	70	-	%	
LOAD FAULT POWER DISSIPATION <sup>4</sup>	Overload	-	-	18	-	-	16	W	
	Short Circuit	-	-	18	-	-	16	W	
CAPACITIVE LOAD <sup>4</sup>		-	-	1000	-	-	1000	μF	
SWITCHING FREQUENCY		400	475	550	400	475	550	kHz	
SYNC FREQUENCY RANGE	V <sub>H</sub> - V <sub>L</sub> = 5V, DC = 20-80%	500	-	600	500	-	600	kHz	
ISOLATION	500 V <sub>DC</sub>	100	-	-	100	-	-	MΩ	
MTBF (MIL-HDBK-217F) <sup>5</sup>	AIF @ T <sub>C</sub> = 55°C	-	552	-	-	552	-	kHrs	
<b>DYNAMIC</b>									
Load Step Output Transient	V <sub>OUT</sub>	Half Load to Full Load	-	90	400	-	180	500	mV <sub>PK</sub>
Load Step Recovery <sup>2</sup>			-	280	500	-	260	500	μSec
Line Step Output Transient <sup>4</sup>	V <sub>OUT</sub>	V <sub>IN</sub> = 16V to 40V	-	300	450	-	300	600	mV <sub>PK</sub>
Line Step Recovery <sup>2, 4</sup>			-	300	450	-	300	500	μSec
Turn On Delay	V <sub>OUT</sub>	V <sub>IN</sub> = 0V to 28V	-	10	20	-	10	20	mSec
Turn On Overshoot			-	0	15	-	0	15	mV <sub>PK</sub>

Notes:

1. Dependent on output voltage.
2. Time for output voltage to settle within 1% of its nominal value.
3. Derate linearly to 0 at 135°C.
4. Verified by initial electrical design verification. Post design verification, parameter shall be guaranteed to the limits specified.
5. Correction factor of 0.12 added to ceramic capacitors.

## SPECIFICATIONS (T<sub>CASE</sub> = -55°C to +125°C, V<sub>IN</sub> = +28V ± 5%, Full Load, Unless Otherwise Specified)

### ABSOLUTE MAXIMUM RATINGS

Input Voltage (Continuous)	50 V <sub>DC</sub>	Junction Temperature Rise to Case	+15°C
Input Voltage (Transient, 1 second)	80 Volts	Storage Temperature	-65°C to +150°C
Output Power <sup>1</sup>	40 Watts	Lead Solder Temperature (10 seconds)	270°C
Power Dissipation (Full Load, T <sub>CASE</sub> = +125°C)	13 Watts	Weight (Maximum) (Un-Flanged / Flanged)	(52 / 55) Grams
ESD Rating per MIL-PRF-38534	3A		

Parameter	Conditions	DVTR2805S			DVTR285R2S			Units	
		Min	Typ	Max	Min	Typ	Max		
<b>STATIC</b>									
INPUT Voltage <sup>4</sup>	Continuous	15	28	50	15	28	50	V	
	Transient, 1 sec	-	-	80	-	-	80	V	
Current	Inhibited	-	4	6	-	4	6	mA	
	No Load	-	55	90	-	55	90	mA	
Ripple Current	Full Load, 20Hz to 10MHz	-	30	50	-	30	50	mA <sub>p-p</sub>	
Inhibit Pin Input <sup>4</sup>		0	-	1.5	0	-	1.5	V	
Inhibit Pin Open Circuit Voltage <sup>4</sup>		9.0	11.0	13.0	9.0	11.0	13.0	V	
UVLO Turn On		12.0	-	14.8	12.0	-	14.8	V	
UVLO Turn Off <sup>4</sup>		11.0	-	14.5	11.0	-	14.5	V	
OUTPUT Voltage	V <sub>OUT</sub> T <sub>CASE</sub> = 25°C	4.95	5	5.05	5.14	5.2	5.26	V	
	V <sub>OUT</sub> T <sub>CASE</sub> = -55°C to +125°C	4.875	5	5.125	5.07	5.2	5.33	V	
Power <sup>3</sup>		0	-	30	0	-	30	W	
Current <sup>3</sup>	V <sub>OUT</sub>	0	-	6	0	-	6	A	
Ripple Voltage	V <sub>OUT</sub> Full Load, 20Hz to 10MHz	-	20	50	-	20	50	mV <sub>p-p</sub>	
Line Regulation	V <sub>OUT</sub> V <sub>IN</sub> = 15V to 50V	-	2	20	-	2	20	mV	
Load Regulation	V <sub>OUT</sub> No Load to Full Load	-	2	50	-	2	50	mV	
EFFICIENCY		72	78	-	72	78	-	%	
LOAD FAULT POWER DISSIPATION <sup>4</sup>	Overload	-	-	16	-	-	16	W	
	Short Circuit	-	-	16	-	-	16	W	
CAPACITIVE LOAD <sup>4</sup>		-	-	1000	-	-	1000	μF	
SWITCHING FREQUENCY		400	475	550	400	475	550	kHz	
SYNC FREQUENCY RANGE	V <sub>H</sub> - V <sub>L</sub> = 5V, DC = 20-80%	500	-	600	500	-	600	kHz	
ISOLATION	500 V <sub>DC</sub>	100	-	-	100	-	-	MΩ	
MTBF (MIL-HDBK-217F) <sup>5</sup>	AIF @ T <sub>C</sub> = 55°C	-	552	-	-	552	-	kHrs	
<b>DYNAMIC</b>									
Load Step Output Transient	V <sub>OUT</sub>	Half Load to Full Load	-	170	500	-	170	500	mV <sub>PK</sub>
Load Step Recovery <sup>2</sup>			-	60	500	-	60	500	μSec
Line Step Output Transient <sup>4</sup>	V <sub>OUT</sub>	V <sub>IN</sub> = 16V to 40V	-	300	600	-	300	600	mV <sub>PK</sub>
Line Step Recovery <sup>2, 4</sup>			-	300	500	-	300	500	μSec
Turn On Delay	V <sub>OUT</sub>	V <sub>IN</sub> = 0V to 28V	-	10	20	-	10	20	mSec
Turn On Overshoot			-	0	25	-	0	25	mV <sub>PK</sub>

Notes:

1. Dependent on output voltage.
2. Time for output voltage to settle within 1% of its nominal value.
3. Derate linearly to 0 at 135°C.
4. Verified by initial electrical design verification. Post design verification, parameter shall be guaranteed to the limits specified.
5. Correction factor of 0.12 added to ceramic capacitors.

## SPECIFICATIONS (T<sub>CASE</sub> = -55°C to +125°C, V<sub>IN</sub> = +28V ± 5%, Full Load, Unless Otherwise Specified)

### ABSOLUTE MAXIMUM RATINGS

Input Voltage (Continuous)	50 V <sub>DC</sub>	Junction Temperature Rise to Case	+15°C
Input Voltage (Transient, 1 second)	80 Volts	Storage Temperature	-65°C to +150°C
Output Power <sup>1</sup>	40 Watts	Lead Solder Temperature (10 seconds)	270°C
Power Dissipation (Full Load, T <sub>CASE</sub> = +125°C)	13 Watts	Weight (Maximum) (Un-Flanged / Flanged)	(52 / 55) Grams
ESD Rating per MIL-PRF-38534	3A		

Parameter	Conditions	DVTR2807S			DVTR2808S			Units	
		Min	Typ	Max	Min	Typ	Max		
<b>STATIC</b>									
INPUT Voltage <sup>4</sup>	Continuous	15	28	50	15	28	50	V	
	Transient, 1 sec	-	-	80	-	-	80	V	
Current	Inhibited	-	4	6	-	4	6	mA	
	No Load	-	65	90	-	65	90	mA	
Ripple Current	Full Load, 20Hz to 10MHz	-	30	50	-	30	50	mA <sub>p-p</sub>	
Inhibit Pin Input <sup>4</sup>		0	-	1.5	0	-	1.5	V	
Inhibit Pin Open Circuit Voltage <sup>4</sup>		9.0	11.0	13.0	9.0	11.0	13.0	V	
UVLO Turn On		12.0	-	14.8	12.0	-	14.8	V	
UVLO Turn Off <sup>4</sup>		11.0	-	14.5	11.0	-	14.5	V	
OUTPUT Voltage	V <sub>OUT</sub> T <sub>CASE</sub> = 25°C	6.93	7	7.07	7.92	8	8.08	V	
	V <sub>OUT</sub> T <sub>CASE</sub> = -55°C to +125°C	6.895	7	7.105	7.88	8	8.12	V	
Power <sup>3</sup>		0	-	35	0	-	35	W	
Current <sup>3</sup>	V <sub>OUT</sub>	0	-	5	0	-	4.4	A	
Ripple Voltage	V <sub>OUT</sub> Full Load, 20Hz to 10MHz	-	30	50	-	30	50	mV <sub>p-p</sub>	
Line Regulation	V <sub>OUT</sub> V <sub>IN</sub> = 15V to 50V	-	2	20	-	2	20	mV	
Load Regulation	V <sub>OUT</sub> No Load to Full Load	-	2	50	-	2	50	mV	
EFFICIENCY		72	76	-	75	79	-	%	
LOAD FAULT POWER DISSIPATION <sup>4</sup>	Overload	-	-	16	-	-	16	W	
	Short Circuit	-	-	16	-	-	16	W	
CAPACITIVE LOAD <sup>4</sup>		-	-	1000	-	-	1000	μF	
SWITCHING FREQUENCY		400	475	550	400	475	550	kHz	
SYNC FREQUENCY RANGE	V <sub>H</sub> - V <sub>L</sub> = 5V, DC = 20-80%	500	-	600	500	-	600	kHz	
ISOLATION	500 V <sub>DC</sub>	100	-	-	100	-	-	MΩ	
MTBF (MIL-HDBK-217F) <sup>5</sup>	AIF @ T <sub>C</sub> = 55°C	-	552	-	-	552	-	kHrs	
<b>DYNAMIC</b>									
Load Step Output Transient	V <sub>OUT</sub>	Half Load to Full Load	-	150	300	-	110	250	mV <sub>PK</sub>
Load Step Recovery <sup>2</sup>			-	100	250	-	60	250	μSec
Line Step Output Transient <sup>4</sup>	V <sub>OUT</sub>	V <sub>IN</sub> = 16V to 40V	-	250	500	-	250	500	mV <sub>PK</sub>
Line Step Recovery <sup>2, 4</sup>			-	250	400	-	250	500	μSec
Turn On Delay	V <sub>OUT</sub>	V <sub>IN</sub> = 0V to 28V	-	10	20	-	10	20	mSec
Turn On Overshoot			-	0	25	-	0	25	mV <sub>PK</sub>

Notes:

1. Dependent on output voltage.
2. Time for output voltage to settle within 1% of its nominal value.
3. Derate linearly to 0 at 135°C.
4. Verified by initial electrical design verification. Post design verification, parameter shall be guaranteed to the limits specified.
5. Correction factor of 0.12 added to ceramic capacitors.

## SPECIFICATIONS (T<sub>CASE</sub> = -55°C to +125°C, V<sub>IN</sub> = +28V ± 5%, Full Load, Unless Otherwise Specified)

### ABSOLUTE MAXIMUM RATINGS

Input Voltage (Continuous)	50 V <sub>DC</sub>	Junction Temperature Rise to Case	+15°C
Input Voltage (Transient, 1 second)	80 Volts	Storage Temperature	-65°C to +150°C
Output Power <sup>1</sup>	40 Watts	Lead Solder Temperature (10 seconds)	270°C
Power Dissipation (Full Load, T <sub>CASE</sub> = +125°C)	13 Watts	Weight (Maximum) (Un-Flanged / Flanged)	(52 / 55) Grams
ESD Rating per MIL-PRF-38534	3A		

Parameter	Conditions	DVTR289R5S			DVTR2812S			Units
		Min	Typ	Max	Min	Typ	Max	
<b>STATIC</b>								
INPUT Voltage <sup>4</sup>	Continuous	15	28	50	15	28	50	V
	Transient, 1 sec	-	-	80	-	-	80	V
Current	Inhibited	-	4	6	-	4	6	mA
	No Load	-	63	90	-	60	90	mA
Ripple Current	Full Load, 20Hz to 10MHz	-	30	50	-	30	50	mA <sub>p-p</sub>
Inhibit Pin Input <sup>4</sup>		0	-	1.5	0	-	1.5	V
Inhibit Pin Open Circuit Voltage <sup>4</sup>		9.0	11.0	13.0	9.0	11.0	13.0	V
UVLO Turn On		12.0	-	14.8	12.0	-	14.8	V
UVLO Turn Off <sup>4</sup>		11.0	-	14.5	11.0	-	14.5	V
OUTPUT Voltage	V <sub>OUT</sub> T <sub>CASE</sub> = 25°C	9.4	9.5	9.6	11.88	12	12.12	V
	V <sub>OUT</sub> T <sub>CASE</sub> = -55°C to +125°C	9.35	9.5	9.64	11.7	12	12.3	V
Power <sup>3</sup>		0	-	40	0	-	40	W
Current <sup>3</sup>	V <sub>OUT</sub>	0	-	4.21	0	-	3.33	A
Ripple Voltage	V <sub>OUT</sub> Full Load, 20Hz to 10MHz	-	30	50	-	20	50	mV <sub>p-p</sub>
Line Regulation	V <sub>OUT</sub> V <sub>IN</sub> = 15V to 50V	-	2	20	-	2	20	mV
Load Regulation	V <sub>OUT</sub> No Load to Full Load	-	2	50	-	10	50	mV
EFFICIENCY		76	82	-	76	84	-	%
LOAD FAULT POWER DISSIPATION <sup>4</sup>	Overload	-	-	16	-	-	14	W
	Short Circuit	-	-	16	-	-	14	W
CAPACITIVE LOAD <sup>4</sup>		-	-	500	-	-	500	μF
SWITCHING FREQUENCY		400	475	550	400	475	550	kHz
SYNC FREQUENCY RANGE	V <sub>H</sub> - V <sub>L</sub> = 5V, DC = 20-80%	500	-	600	500	-	600	kHz
ISOLATION	500 V <sub>DC</sub>	100	-	-	100	-	-	MΩ
MTBF (MIL-HDBK-217F) <sup>5</sup>	AIF @ T <sub>C</sub> = 55°C	-	552	-	-	552	-	kHrs
<b>DYNAMIC</b>								
Load Step Output Transient	V <sub>OUT</sub> Half Load to Full Load	-	500	700	-	450	700	mV <sub>PK</sub>
Load Step Recovery <sup>2</sup>		-	200	500	-	200	500	μSec
Line Step Output Transient <sup>4</sup>	V <sub>OUT</sub> V <sub>IN</sub> = 16V to 40V	-	900	1500	-	500	900	mV <sub>PK</sub>
Line Step Recovery <sup>2, 4</sup>	P <sub>OUT</sub> = 30W	-	300	500	-	300	500	μSec
Turn On Delay	V <sub>OUT</sub> V <sub>IN</sub> = 0V to 28V	-	10	20	-	10	20	μSec
Turn On Overshoot		-	0	50	-	0	50	mV <sub>PK</sub>

Notes:

1. Dependent on output voltage.
2. Time for output voltage to settle within 1% of its nominal value.
3. Derate linearly to 0 at 135°C.
4. Verified by initial electrical design verification. Post design verification, parameter shall be guaranteed to the limits specified.
5. Correction factor of 0.12 added to ceramic capacitors.

## SPECIFICATIONS (T<sub>CASE</sub> = -55°C to +125°C, V<sub>IN</sub> = +28V ± 5%, Full Load, Unless Otherwise Specified)

### ABSOLUTE MAXIMUM RATINGS

Input Voltage (Continuous)	50 V <sub>DC</sub>	Junction Temperature Rise to Case	+15°C
Input Voltage (Transient, 1 second)	80 Volts	Storage Temperature	-65°C to +150°C
Output Power <sup>1</sup>	40 Watts	Lead Solder Temperature (10 seconds)	270°C
Power Dissipation (Full Load, T <sub>CASE</sub> = +125°C)	13 Watts	Weight (Maximum) (Un-Flanged / Flanged)	(52 / 55) Grams
ESD Rating per MIL-PRF-38534	3A		

Parameter	Conditions	DVTR2815S			DVTR2818S			Units
		Min	Typ	Max	Min	Typ	Max	
<b>STATIC</b>								
INPUT Voltage <sup>4</sup>	Continuous	15	28	50	15	28	50	V
	Transient, 1 sec	-	-	80	-	-	80	V
Current	Inhibited	-	4	6	-	4	6	mA
	No Load	-	60	90	-	60	90	mA
Ripple Current	Full Load, 20Hz to 10MHz	-	30	50	-	30	50	mA <sub>p-p</sub>
Inhibit Pin Input <sup>4</sup>		0	-	1.5	0	-	1.5	V
Inhibit Pin Open Circuit Voltage <sup>4</sup>		9.0	11.0	13.0	9.0	11.0	13.0	V
UVLO Turn On		12.0	-	14.8	12.0	-	14.8	V
UVLO Turn Off <sup>4</sup>		11.0	-	14.5	11.0	-	14.5	V
OUTPUT Voltage	V <sub>OUT</sub> T <sub>CASE</sub> = 25°C	14.85	15	15.15	17.82	18	18.18	V
	V <sub>OUT</sub> T <sub>CASE</sub> = -55°C to +125°C	14.625	15	15.375	17.55	18	18.45	V
Power <sup>3</sup>		0	-	40	0	-	40	W
Current <sup>3</sup>	V <sub>OUT</sub> 0	0	-	2.67	0	-	2.22	A
Ripple Voltage	V <sub>OUT</sub> Full Load, 20Hz to 10MHz	-	20	50	-	20	50	mV <sub>p-p</sub>
Line Regulation	V <sub>OUT</sub> V <sub>IN</sub> = 15V to 50V	-	2	20	-	2	20	mV
Load Regulation	V <sub>OUT</sub> No Load to Full Load	-	10	50	-	10	50	mV
EFFICIENCY		77	84	-	77	84	-	%
LOAD FAULT POWER DISSIPATION <sup>4</sup>	Overload	-	-	14	-	-	14	W
	Short Circuit	-	-	14	-	-	14	W
CAPACITIVE LOAD <sup>4</sup>		-	-	500	-	-	500	μF
SWITCHING FREQUENCY		400	475	550	400	475	550	kHz
SYNC FREQUENCY RANGE	V <sub>H</sub> - V <sub>L</sub> = 5V, DC = 20-80%	500	-	600	500	-	600	kHz
ISOLATION	500 V <sub>DC</sub>	100	-	-	100	-	-	MΩ
MTBF (MIL-HDBK-217F) <sup>5</sup>	AIF @ T <sub>C</sub> = 55°C	-	552	-	-	552	-	kHrs
<b>DYNAMIC</b>								
Load Step Output Transient	V <sub>OUT</sub> Half Load to Full Load	-	500	700	-	450	700	mV <sub>PK</sub>
Load Step Recovery <sup>2</sup>		-	150	500	-	200	400	μSec
Line Step Output Transient <sup>4</sup>	V <sub>OUT</sub> V <sub>IN</sub> = 16V to 40V	-	500	900	-	1000	1600	mV <sub>PK</sub>
Line Step Recovery <sup>2, 4</sup>	P <sub>OUT</sub> = 30W	-	300	500	-	350	550	μSec
Turn On Delay	V <sub>OUT</sub> V <sub>IN</sub> = 0V to 28V	-	10	20	-	10	20	mSec
Turn On Overshoot		-	0	50	-	0	50	mV <sub>PK</sub>

Notes:

1. Dependent on output voltage.
2. Time for output voltage to settle within 1% of its nominal value.
3. Derate linearly to 0 at 135°C.
4. Verified by initial electrical design verification. Post design verification, parameter shall be guaranteed to the limits specified.
5. Correction factor of 0.12 added to ceramic capacitors.

## SPECIFICATIONS (T<sub>CASE</sub> = -55°C to +125°C, V<sub>IN</sub> = +28V ± 5%, Full Load, Unless Otherwise Specified)

### ABSOLUTE MAXIMUM RATINGS

Input Voltage (Continuous)	50 V <sub>DC</sub>	Junction Temperature Rise to Case	+15°C
Input Voltage (Transient, 1 second)	80 Volts	Storage Temperature	-65°C to +150°C
Output Power <sup>1</sup>	40 Watts	Lead Solder Temperature (10 seconds)	270°C
Power Dissipation (Full Load, T <sub>CASE</sub> = +125°C)	13 Watts	Weight (Maximum) (Un-Flanged / Flanged)	(52 / 55) Grams
ESD Rating per MIL-PRF-38534	3A		

Parameter	Conditions	DVTR2828S			Units
		Min	Typ	Max	
<b>STATIC</b>					
INPUT Voltage <sup>4</sup>	Continuous	15	28	50	V
	Transient, 1 sec	-	-	80	V
Current	Inhibited	-	4	6	mA
	No Load	-	60	90	mA
Ripple Current	Full Load, 20Hz to 10MHz	-	30	50	mA <sub>p-p</sub>
Inhibit Pin Input <sup>4</sup>		0	-	1.5	V
Inhibit Pin Open Circuit Voltage <sup>4</sup>		9.0	11.0	13.0	V
UVLO Turn On		12.0	-	14.8	V
UVLO Turn Off <sup>4</sup>		11.0	-	14.5	V
OUTPUT Voltage	V <sub>OUT</sub> T <sub>CASE</sub> = 25°C	27.72	28	28.28	V
	V <sub>OUT</sub> T <sub>CASE</sub> = -55°C to +125°C	27.30	28	28.70	V
Power <sup>3</sup>		0	-	40	W
Current <sup>3</sup>	V <sub>OUT</sub>	0	-	1.43	A
Ripple Voltage	V <sub>OUT</sub> Full Load, 20Hz to 10MHz	-	30	150	mV <sub>p-p</sub>
Line Regulation	V <sub>OUT</sub> V <sub>IN</sub> = 15V to 50V	-	2	150	mV
Load Regulation	V <sub>OUT</sub> No Load to Full Load	-	20	150	mV
EFFICIENCY		79	84	-	%
LOAD FAULT POWER DISSIPATION <sup>4</sup>	Overload	-	-	14	W
	Short Circuit	-	-	14	W
CAPACITIVE LOAD <sup>4</sup>		-	-	500	μF
SWITCHING FREQUENCY		400	475	550	kHz
SYNC FREQUENCY RANGE	V <sub>H</sub> - V <sub>L</sub> = 5V, DC = 20-80%	500	-	600	kHz
ISOLATION	500 V <sub>DC</sub>	100	-	-	MΩ
MTBF (MIL-HDBK-217F) <sup>5</sup>	AIF @ T <sub>C</sub> = 55°C	-	552	-	kHrs
<b>DYNAMIC</b>					
Load Step Output Transient	V <sub>OUT</sub> Half Load to Full Load	-	850	1200	mV <sub>PK</sub>
Load Step Recovery <sup>2</sup>			250	400	μSec
Line Step Output Transient <sup>4</sup>	V <sub>OUT</sub> V <sub>IN</sub> = 16V to 40V	-	1500	2800	mV <sub>PK</sub>
Line Step Recovery <sup>2, 4</sup>			350	600	μSec
Turn On Delay	V <sub>OUT</sub> V <sub>IN</sub> = 0V to 28V	-	10	20	mSec
Turn On Overshoot		-	0	50	mV <sub>PK</sub>

Notes:

1. Dependent on output voltage.
2. Time for output voltage to settle within 1% of its nominal value.
3. Derate linearly to 0 at 135°C.
4. Verified by initial electrical design verification. Post design verification, parameter shall be guaranteed to the limits specified.
5. Correction factor of 0.12 added to ceramic capacitors.

**BLOCK DIAGRAM**

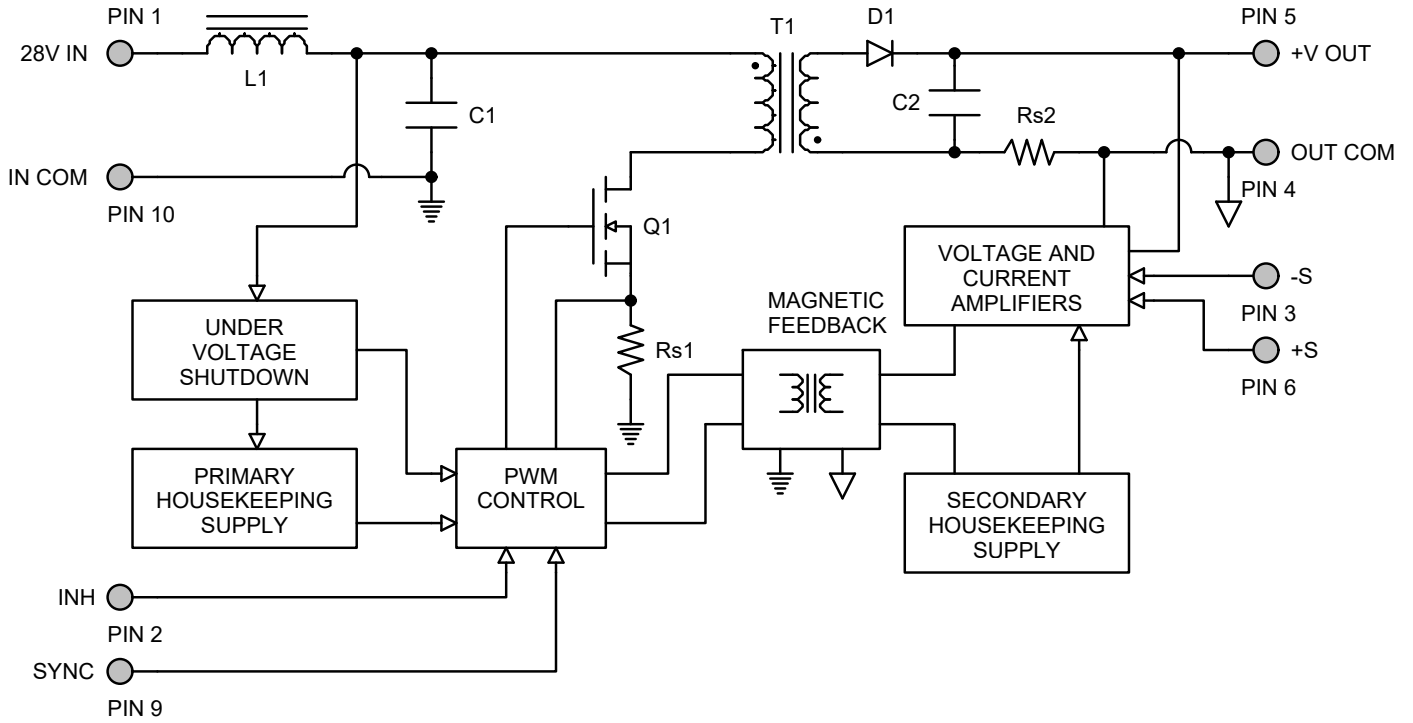


Figure 2

**CONNECTION DIAGRAM**

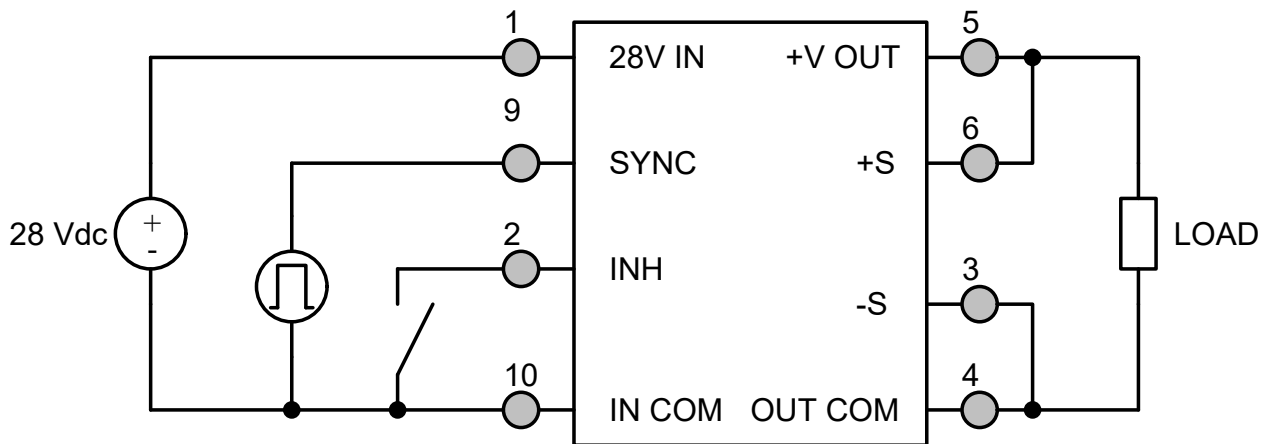
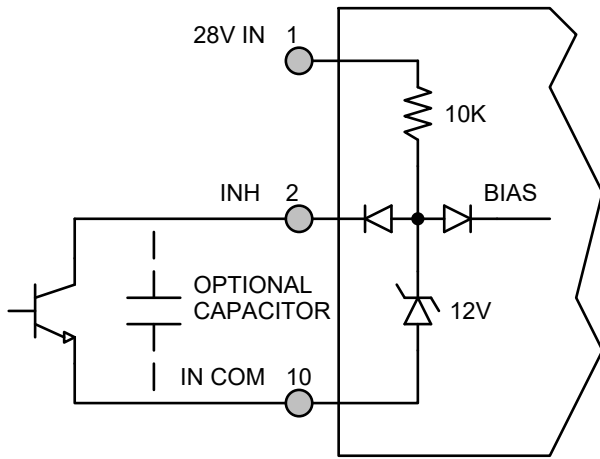
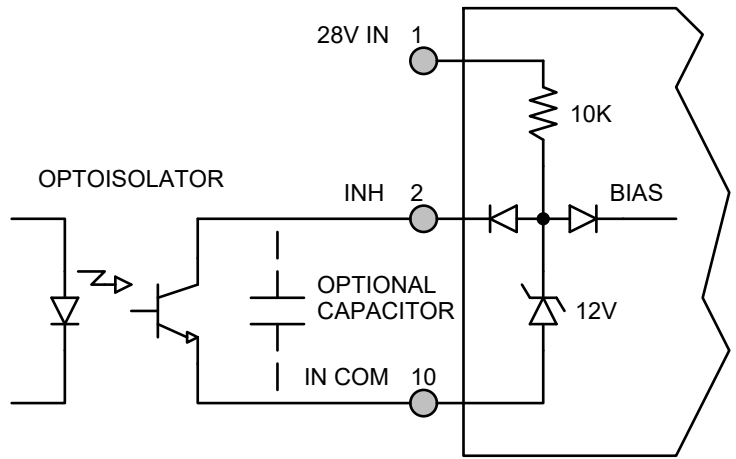


Figure 3

**INHIBIT DRIVE CONNECTION DIAGRAMS**

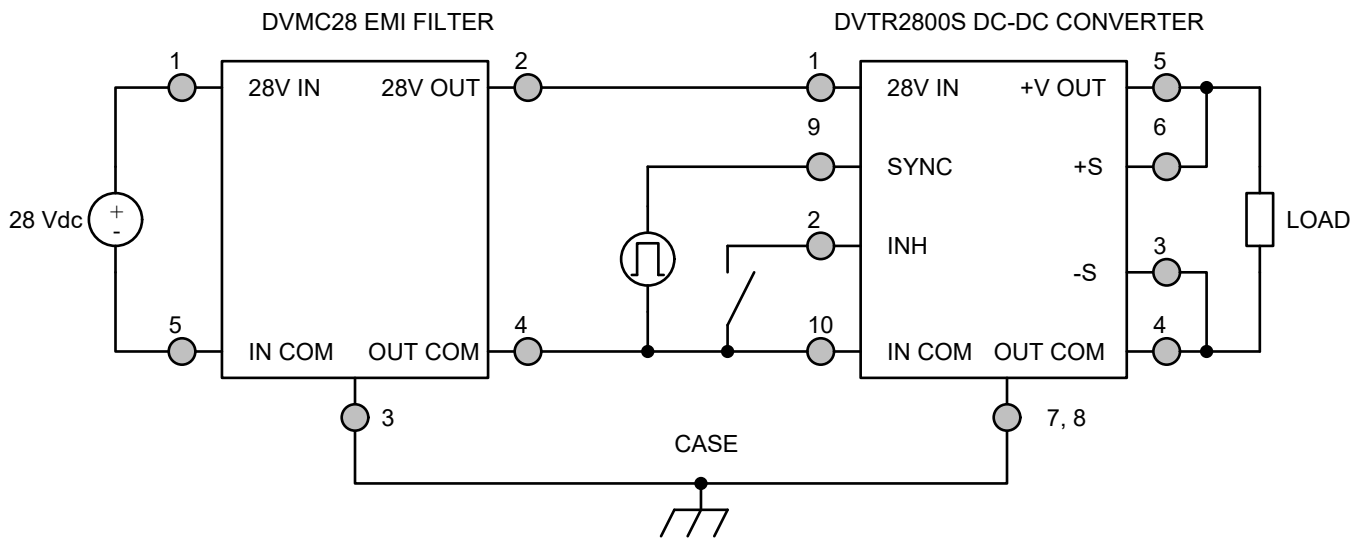


**Figure 4** – Internal Inhibit Circuit and Recommended Drive  
(Shown with optional capacitor for turn-on delay)



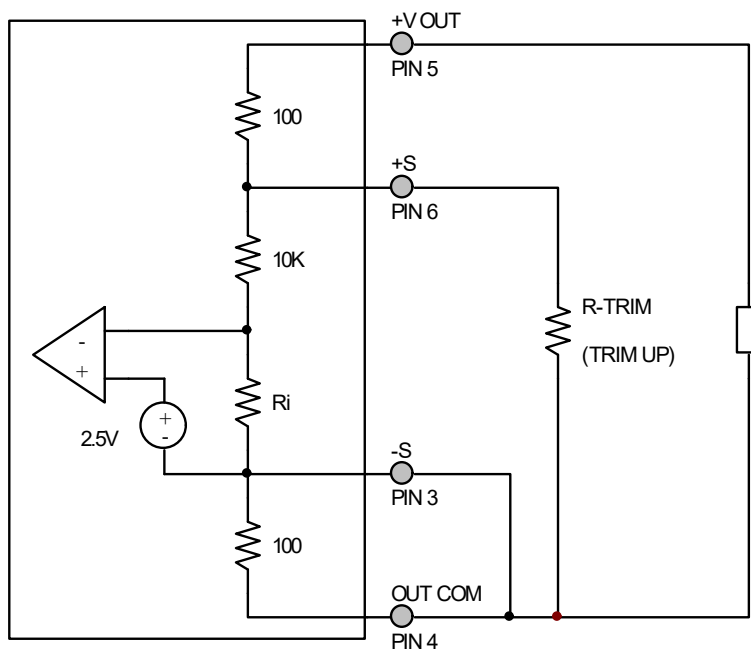
**Figure 5** – Isolated Inhibit Drive  
(Shown with optional capacitor for turn-on delay)

**EMI FILTER HOOKUP DIAGRAM**



**Figure 6** – Converter with EMI Filter

**OUTPUT VOLTAGE TRIM**



The output voltage can be trimmed up by connecting a resistor between the +S pin (PIN 6) and the OUT COM pin (PIN 4). The maximum trim range is +10%. The appropriate resistor values versus the output voltage are given in the trim table below. The -S pin should be connected to the OUT COM pin.

Figure 7 – Output Voltage Trim

DVTR282R5S		DVTR283R3S		DVTR2805S		DVTR285R2S		DVTR2807S	
+V <sub>OUT</sub> (V)	R <sub>TRIM</sub> (Ω)	+V <sub>OUT</sub> (V)	R <sub>TRIM</sub> (Ω)	+V <sub>OUT</sub> (V)	R <sub>TRIM</sub> (Ω)	+V <sub>OUT</sub> (V)	R <sub>TRIM</sub> (Ω)	+V <sub>OUT</sub> (V)	R <sub>TRIM</sub> (Ω)
2.75	1.05k	3.60	1.13k	5.50	1.05k	5.70	1.09k	7.70	1.07k
2.70	1.33k	3.55	1.36k	5.45	1.18k	5.65	1.22k	7.65	1.16k
2.65	1.82k	3.50	1.72k	5.40	1.33k	5.60	1.39k	7.60	1.26k
2.60	2.86k	3.45	2.32k	5.35	1.54k	5.55	1.60k	7.55	1.39k
2.55	6.67k	3.40	3.59k	5.30	1.82k	5.50	1.89k	7.50	1.54k
2.50	-	3.35	7.87k	5.25	2.22k	5.45	2.31k	7.45	1.73k
		3.30	-	5.20	2.86k	5.40	2.97k	7.40	1.97k
				5.15	4.00k	5.35	4.16k	7.35	2.29k
				5.10	6.67k	5.30	6.93k	7.30	2.74k
				5.05	20.0k	5.25	20.8k	7.25	3.41k
				5.00	-	5.20	-	7.20	4.51k
								7.15	6.64k
								7.10	12.6k
								7.05	131k
								7.00	-

(Continued on next page)

## OUTPUT VOLTAGE TRIM

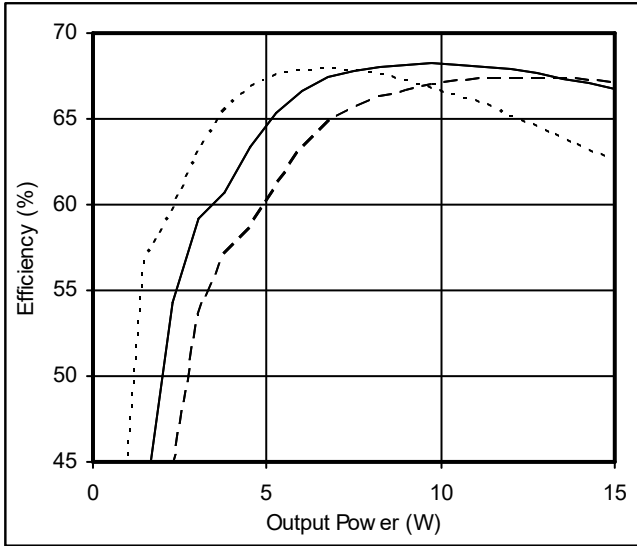
DVTR2808S		DVTR289R5S		DVTR2812S		DVTR2815S	
+V <sub>OUT</sub> (V)	R <sub>TRIM</sub> (Ω)	+V <sub>OUT</sub> (V)	R <sub>TRIM</sub> (Ω)	+V <sub>OUT</sub> (V)	R <sub>TRIM</sub> (Ω)	+V <sub>OUT</sub> (V)	R <sub>TRIM</sub> (Ω)
8.8	1.07k	10.5	1.02k	13.2	1.09k	16.50	1.09k
8.7	1.24k	10.4	1.15k	13.1	1.19k	16.40	1.18k
8.6	1.47k	10.3	1.31k	13.0	1.33k	16.30	1.28k
8.5	1.80k	10.2	1.52k	12.9	1.49k	16.20	1.40k
8.4	2.32k	10.1	1.8k	12.8	1.70k	16.10	1.54k
8.3	3.27k	10	2.22k	12.7	1.98k	16.00	1.71k
8.2	5.52k	9.9	2.9k	12.6	2.38k	15.90	1.94k
8.1	17.8k	9.8	4.18k	12.5	2.96k	15.80	2.22k
8.0	-	9.7	7.47k	12.4	3.94k	15.70	2.61k
		9.6	34.97k	12.3	5.86k	15.60	3.16k
		9.5	-	12.2	11.4k	15.50	4.00k
				12.1	242k	15.40	5.46k
				12.0	-	15.30	8.57k
						15.20	20.0k
						15.10	Note 1
						15.00	-

DVTR2818S		DVTR2828S	
+V <sub>OUT</sub> (V)	R <sub>TRIM</sub> (Ω)	+V <sub>OUT</sub> (V)	R <sub>TRIM</sub> (Ω)
19.8	1.09k	30.8	1.10k
19.6	1.24k	30.6	1.19k
19.4	1.43k	30.4	1.30k
19.2	1.70k	30.2	1.44k
19.0	2.10k	30.0	1.60k
18.8	2.74k	29.8	1.81k
18.6	3.94k	29.6	2.07k
18.4	7.00k	29.4	2.44k
18.2	31.5k	29.2	2.95k
18.0	-	29.0	3.73k
		28.8	5.09k
		28.6	8.00k
		28.4	18.7k
		28.2	Note 1
		28.0	-

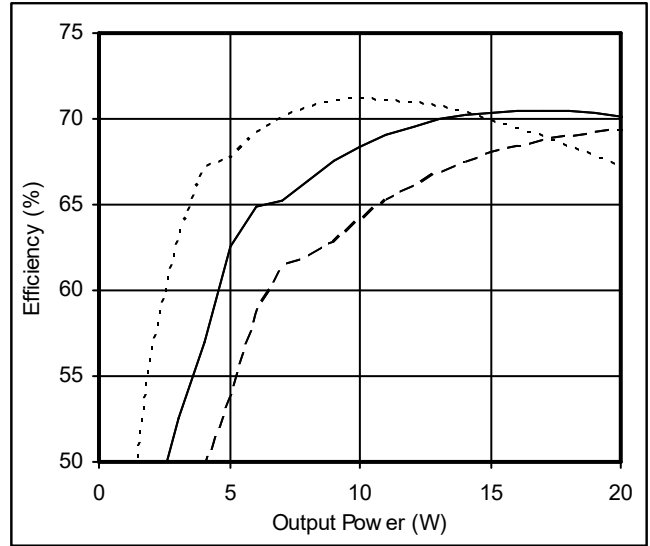
Notes: 1. Connect R-TRIM = 400Ω from +VOUT (PIN 5) to +S (PIN 6).

**EFFICIENCY PERFORMANCE CURVES** ( $T_{CASE} = 25^{\circ}C$ , Full Load, Unless Otherwise Specified)

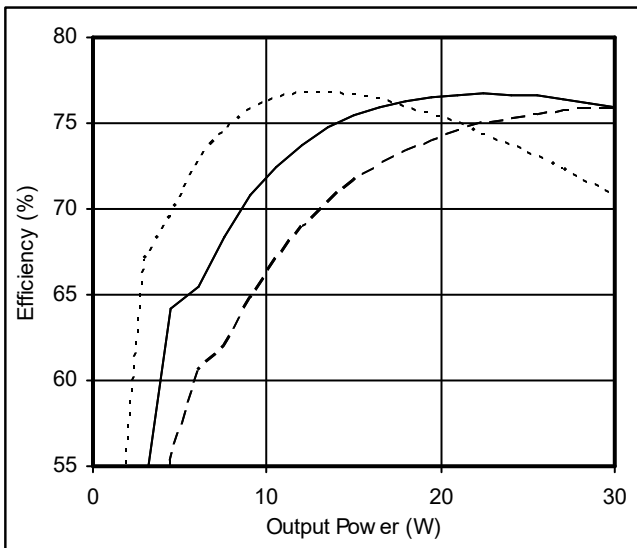
-----  $V_{IN} = 16V$       ———  $V_{IN} = 28V$       - - - -  $V_{IN} = 40V$



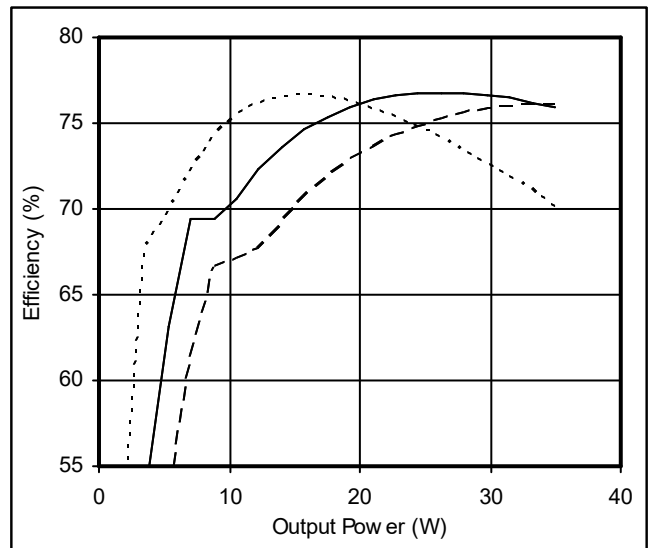
**Figure 8 – DVTR282R5S**  
Efficiency (%) vs. Output Power (W)



**Figure 9 – DVTR283R3S**  
Efficiency (%) vs. Output Power (W)



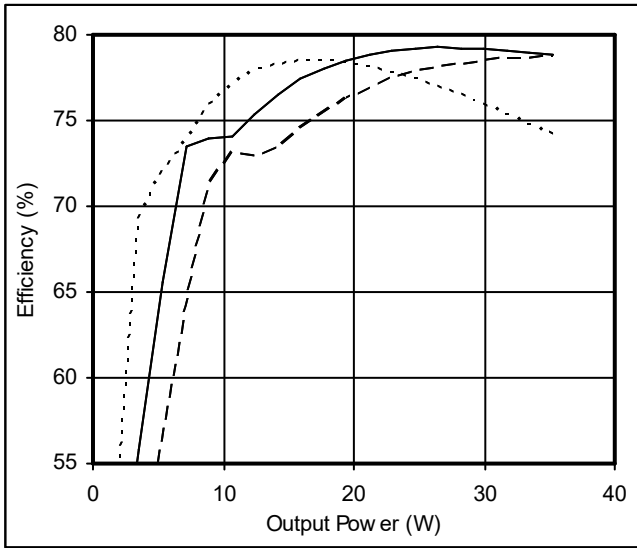
**Figure 10 – DVTR2805S / DVTR285R2S**  
Efficiency (%) vs. Output Power (W)



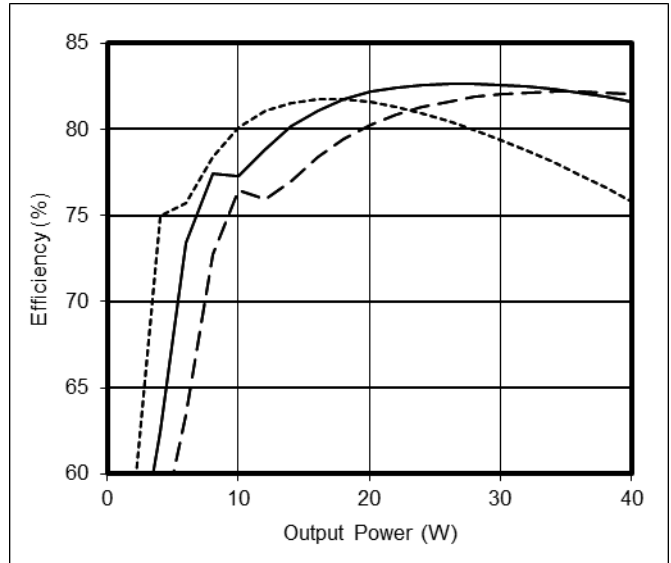
**Figure 11 – DVTR2807S**  
Efficiency (%) vs. Output Power (W)

**EFFICIENCY PERFORMANCE CURVES** ( $T_{CASE} = 25^{\circ}C$ , Full Load, Unless Otherwise Specified)

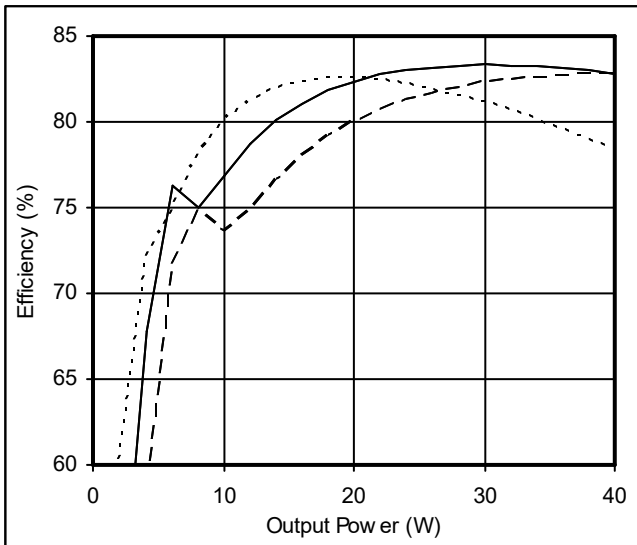
-----  $V_{IN} = 16V$       ———  $V_{IN} = 28V$       - - - - -  $V_{IN} = 40V$



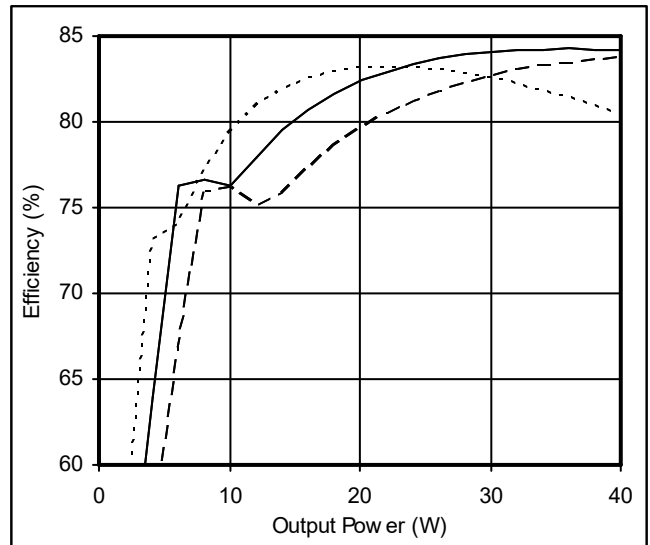
**Figure 12 – DVTR2808S**  
Efficiency (%) vs. Output Power (W)



**Figure 13 – DVTR289R5S**  
Efficiency (%) vs. Output Power (W)

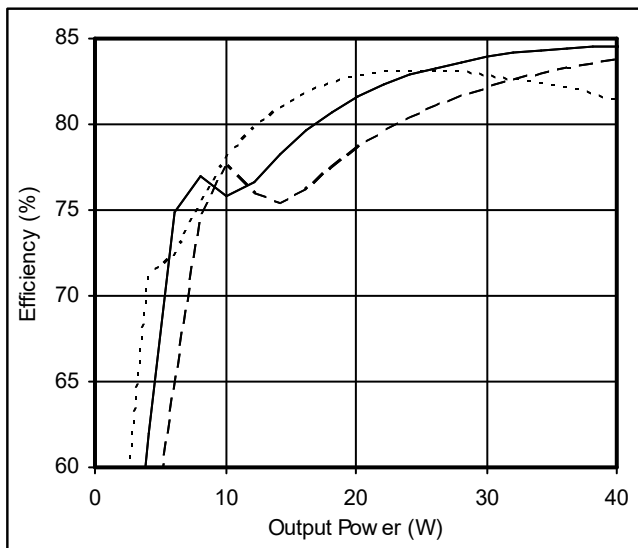
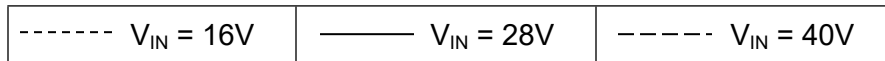


**Figure 14 – DVTR2812S**  
Efficiency (%) vs. Output Power (W)

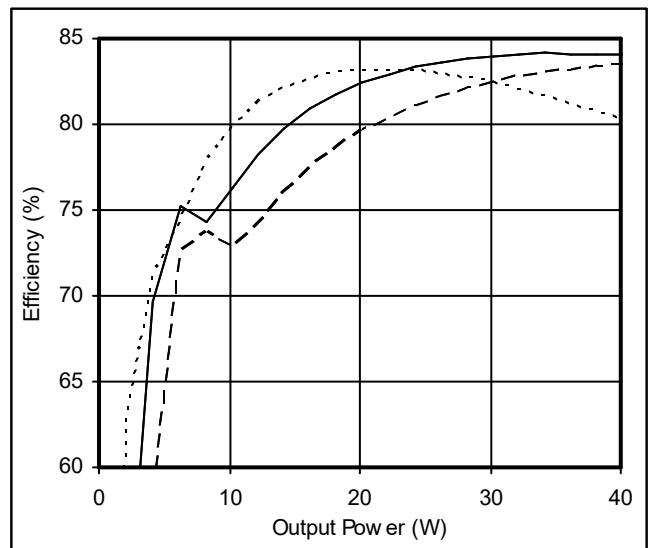


**Figure 15 – DVTR2815S**  
Efficiency (%) vs. Output Power (W)

**EFFICIENCY PERFORMANCE CURVES** ( $T_{CASE} = 25^{\circ}C$ , Full Load, Unless Otherwise Specified)



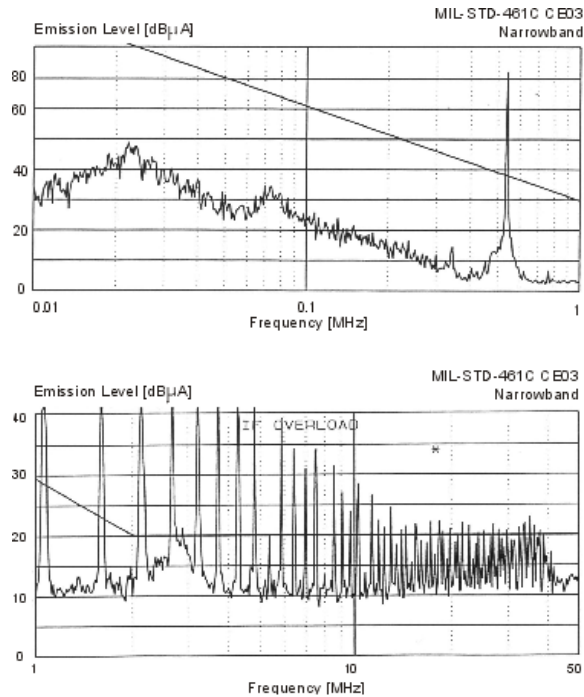
**Figure 16 – DVTR2818S**  
Efficiency (%) vs. Output Power (W)



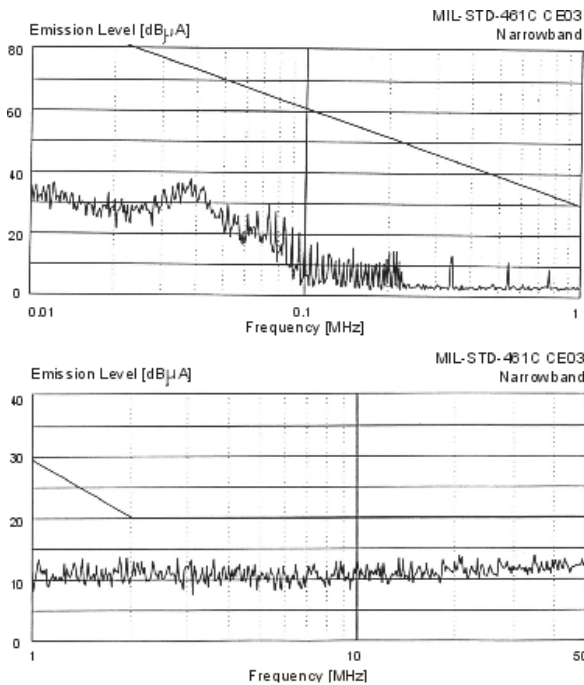
**Figure 17 – DVTR2828S**  
Efficiency (%) vs. Output Power (W)

**EMI PERFORMANCE CURVES**

( $T_{CASE} = 25^{\circ}C$ ,  $V_{IN} = +28V \pm 5\%$ , Full Load, Unless Otherwise Specified)

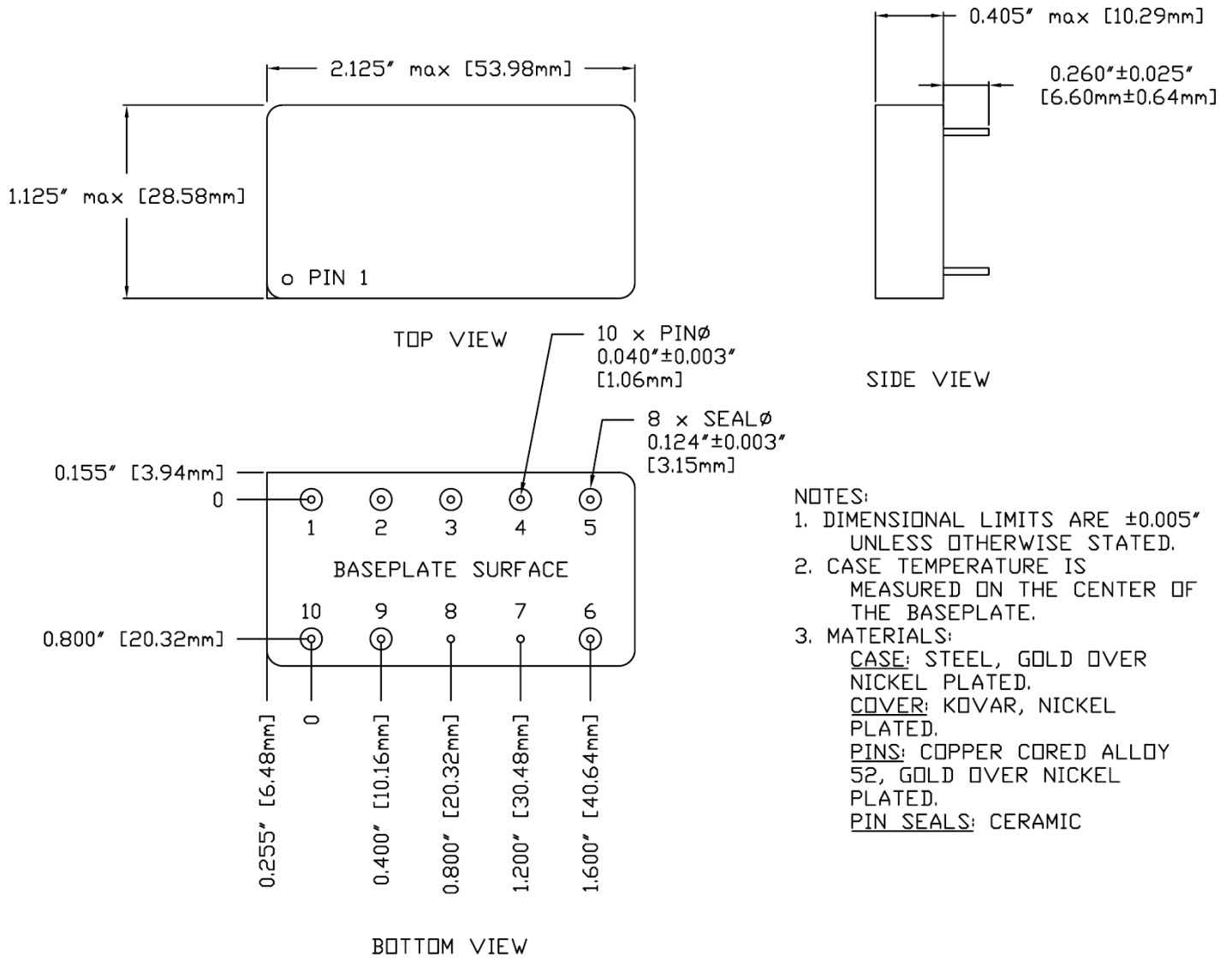


**Figure 18 – DVTR2800S without EMI Filter**



**Figure 19 – DVTR2800S with EMI Filter**

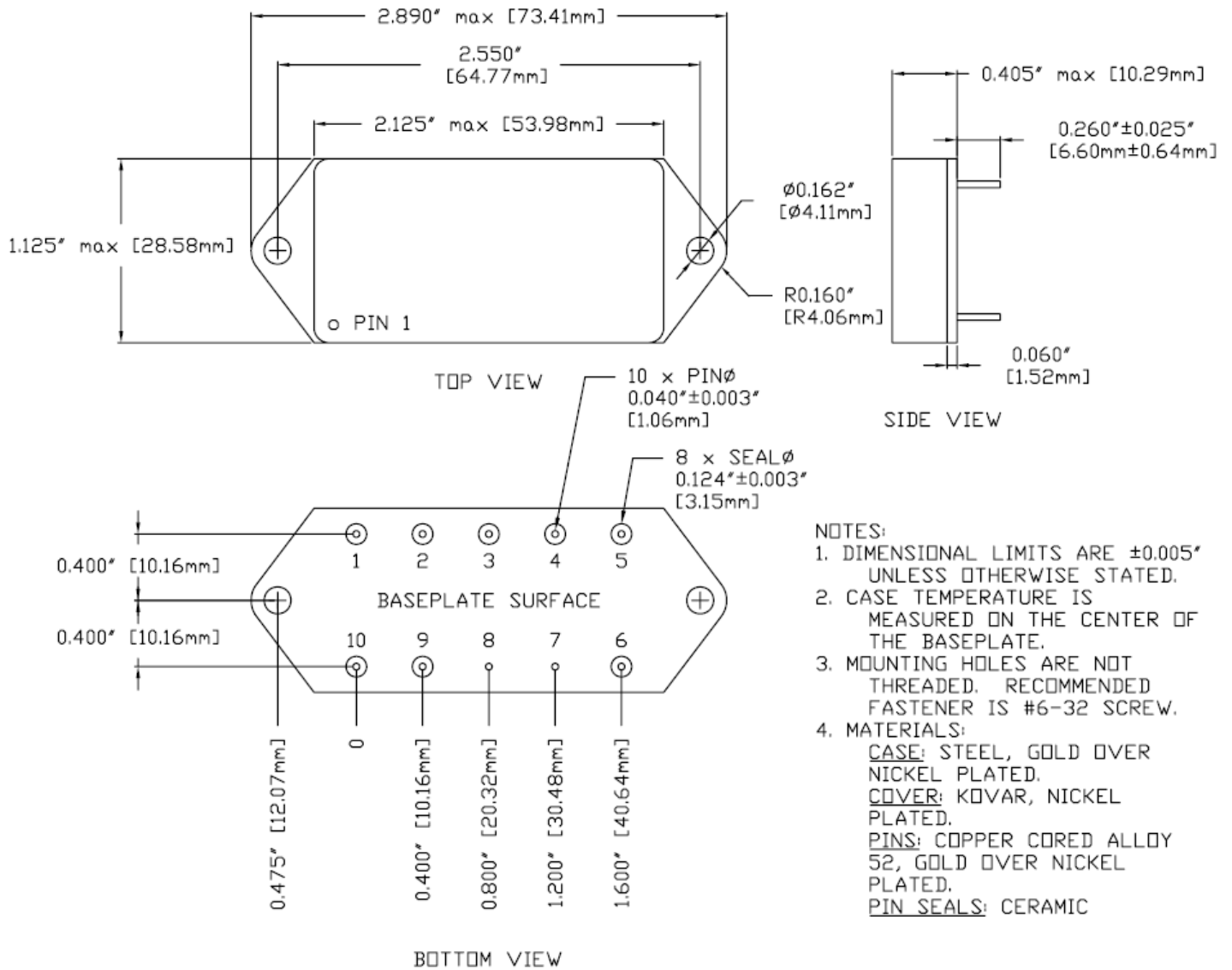
**PACKAGE SPECIFICATIONS (NON-FLANGED, SEAM SEAL)**



Pin	Function	Pin	Function
1	28V IN	6	+S
2	INHIBIT	7	CASE
3	-S	8	CASE
4	OUT COM	9	SYNC
5	+V OUT	10	IN COM

**Figure 20** – Non-Flanged, Seam Seal Package and Pinout

**PACKAGE SPECIFICATIONS (FLANGED, SEAM SEAL)**



Pin	Function	Pin	Function
1	28V IN	6	+S
2	INHIBIT	7	CASE
3	-S	8	CASE
4	OUT COM	9	SYNC
5	+V OUT	10	IN COM

**Figure 21 – Flanged, Seam Seal Package and Pinout**

## PACKAGE PIN DESCRIPTION

Pin	Function	Description
1	28V IN	Positive Input Voltage Connection
2	INHIBIT	Logic Low = Disabled Output. Connecting the inhibit pin to input common causes converter shutdown. Logic High = Enabled Output. Unconnected or open collector TTL.
3	-S	Return Sense
4	OUT COM	Output Common Connection
5	+V OUT	Positive Output Voltage Connection
6	+S	Positive Sense
7	CASE	Case Connection
8	CASE	Case Connection
9	SYNC	Synchronization Signal
10	IN COM	Input Common Connection

## ENVIRONMENTAL SCREENING (100% Tested Per MIL-STD-883 as referenced to MIL-PRF-38534)

Test	MIL-STD-883 Test Method, Condition	No Suffix (Standard) Non-QML 5	/ES (Extended) Non-QML 5	/H (Class H)	/KL1 Non-QML 5,9
Non-Destructive Bond Pull	TM2023	• <sup>4</sup>	• <sup>4</sup>	• <sup>4</sup>	•
Internal Visual	TM2010, TM2017, TM2032 (MIL-STD-750, TM2072, TM2073)	•	•	•	•
Temperature Cycling	TM1010, Condition C -65°C to 150°C, Ambient			•	•
	TM1010, Condition B -55°C to 125°C, Ambient		•		
Constant Acceleration	TM2001, 3000g, Y1 Direction			•	•
	TM2001, 500g, Y1 Direction		•		
PIND <sup>7</sup>	TM2020, Condition A				•
Pre Burn-In Electrical	25°C				•
Burn-In	TM1015, 320 hrs, 125°C, Case Typ				•
	TM1015, 160 hrs, 125°C, Case Typ			•	
	96 hrs, 125°C, Case Typ 24 hrs, 125°C, Case Typ	•	•		
Final Electrical	MIL-PRF-38534, Group A Subgroups 1-6 -55°C, 25°C, 125°C <sup>3</sup>			•	•
	MIL-PRF-38534, Group A Subgroups 1 and 4 25°C	•	•		
Hermeticity (Seal)	TM1014, Fine Leak, Condition A2 or B1		•	•	•
	TM1014, Gross Leak, Condition C1 or B2		•	•	•
	Gross Leak, Dip (No Bomb), Visual Verification	•			
Radiography <sup>8</sup>	TM2012				•
External Visual	TM2009	•	•	•	•

- Notes:
- Contact Sales for more information concerning additional environmental screening and testing options desired.
  - VPT Inc. reserves the right to ship higher screened or SMD products to meet lower screened orders at our sole discretion unless specifically forbidden by customer contract.
  - 100% R&R testing with all test data included in product shipment.
  - Not required per MIL-PRF-38534. Test is performed for additional product quality assurance.
  - Non-QML products may not meet all requirements of MIL-PRF-38534.
  - Note intentionally not used.
  - PIND test Certificate of Compliance included in product shipment.
  - Radiographic test Certificate of Compliance and film(s) or data CD included in product shipment.
  - KL1 products are identical in every way with Class K products in compliance with MIL-PRF-38534 revision L and later revisions except they contain elements evaluated to the requirements of MIL-PRF-38534 revision K and previous revisions. These devices are not marked with an SMD number or MIL-PRF-38534 certification mark and are marked with -KL1 screening code in place of -K.

## ORDERING INFORMATION

<b>DVTR</b>	<b>28</b>	<b>05</b>	<b>S</b>	<b>F</b>	<b>/KL1</b>	-	<b>XXX</b>
1	2	3	4	5	6		7

	(1)	(2)	(3)		(4)	
Product Series	Nominal Input Voltage	Output Voltage	Output Voltage		Number of Outputs	
<b>DVTR</b>	<b>28</b>	28 Volts	<b>2R5</b>	2.5 Volts	<b>S</b>	Single
			<b>3R3</b>	3.3 Volts		
			<b>05</b>	5 Volts		
			<b>5R2</b>	5.2 Volts		
			<b>07</b>	7 Volts		
			<b>08</b>	8 Volts		
			<b>9R5</b>	9.5 Volts		
			<b>12</b>	12 Volts		
			<b>15</b>	15 Volts		
			<b>18</b>	18 Volts		
			<b>28</b>	28 Volts		

(5)		(6)		(7)
Package Option		Screening Code <sup>1,2,3</sup>		Additional Screening Code
<b>None</b>	Non-Flanged	<b>None</b>	Standard	Contact Sales
<b>F</b>	Flanged	<b>/ES</b>	Extended	
		<b>/H</b>	Class H	
		<b>/KL1</b>	Class KL1	

- Notes:
1. Contact the VPT Inc. Sales Department for availability of Class H (/H) and KL1 (/KL1) qualified products.
  2. VPT Inc. reserves the right to ship higher screened or SMD products to meet lower screened orders at our sole discretion unless specifically forbidden by customer contract.
  3. -KL1 products are identical in every way with Class K products in compliance with MIL-PRF-38534 revision L and later revisions except they contain elements evaluated to the requirements of MIL-PRF-38534 revision K and previous revisions. These devices are not marked with an SMD number or MIL-PRF-38534 certification mark and are marked with -KL1 screening code in place of -K.

Please contact your sales representative or the VPT Inc. Sales Department for more information concerning additional environmental screening and testing, different input voltage, output voltage, power requirement, source inspection, and/or special element evaluation for space or other higher quality applications.

## SMD (STANDARD MICROCIRCUIT DRAWING) NUMBERS

Standard Microcircuit Drawing (SMD)	DVTR2800S Series Similar Part Number
5962-1122401HXC	DVTR282R5S/H
5962-1122401HXA	DVTR282R5S/H-E
5962-1122401HYC	DVTR282R5SF/H
5962-1122401HYA	DVTR282R5SF/H-E
5962-1122402HXC	DVTR283R3S/H
5962-1122402HXA	DVTR283R3S/H-E
5962-1122402HYC	DVTR283R3SF/H
5962-1122402HYA	DVTR283R3SF/H-E
5962-1122403HXC	DVTR2805S/H
5962-1122403HXA	DVTR2805S/H-E
5962-1122403HYC	DVTR2805SF/H
5962-1122403HYA	DVTR2805SF/H-E
5962-1122404HXC	DVTR285R2S/H
5962-1122404HXA	DVTR285R2S/H-E
5962-1122404HYC	DVTR285R2SF/H
5962-1122404HYA	DVTR285R2SF/H-E
5962-1122405HXC	DVTR2812S/H
5962-1122405HXA	DVTR2812S/H-E
5962-1122405HYC	DVTR2812SF/H
5962-1122405HYA	DVTR2812SF/H-E
5962-1122406HXC	DVTR2815S/H
5962-1122406HXA	DVTR2815S/H-E
5962-1122406HYC	DVTR2815SF/H
5962-1122406HYA	DVTR2815SF/H-E

Standard Microcircuit Drawing (SMD)	DVTR2800S Series Similar Part Number
5962-1122407HXC	DVTR2828S/H
5962-1122407HXA	DVTR2828S/H-E
5962-1122407HYC	DVTR2828SF/H
5962-1122407HYA	DVTR2828SF/H-E
5962-1122408HXC	DVTR289R5S/H
5962-1122408HXA	DVTR289R5S/H-E
5962-1122408HYC	DVTR289R5SF/H
5962-1122408HYA	DVTR289R5SF/H-E
5962-1122409HXC	DVTR2808S/H
5962-1122409HXA	DVTR2808S/H-E
5962-1122409HYC	DVTR2808SF/H
5962-1122409HYA	DVTR2808SF/H-E
5962-1122410HXC	DVTR2818S/H
5962-1122410HXA	DVTR2818S/H-E
5962-1122410HYC	DVTR2818SF/H
5962-1122410HYA	DVTR2818SF/H-E
5962-1122411HXC	DVTR2807S/H
5962-1122411HXA	DVTR2807S/H-E
5962-1122411HYC	DVTR2807SF/H
5962-1122411HYA	DVTR2807SF/H-E

Do not use the DVTR2800S Series similar part number for SMD product acquisition. It is listed for reference only. For exact specifications for the SMD product, refer to the SMD drawing. SMDs can be downloaded from the DLA Land and Maritime (Previously known as DSCC) website at <https://landandmaritimeapps.dla.mil/programs/defaultapps.asp>. The SMD number listed above represents the Federal Stock Class, Device Type, Device Class Designator, Case Outline, Lead Finish and RHA Designator (where applicable). Please reference the SMD for other screening levels, lead finishes, and radiation levels. All SMD products are marked with a "Q" on the cover as specified by the QML certification mark requirement of MIL-PRF-38534.

## CONTACT INFORMATION

To request a quotation or place orders please contact your sales representative or the VPT Inc. Sales Department at:

**Phone:** (425) 353-3010  
**Fax:** (425) 353-4030  
**E-mail:** [vptsales@vptpower.com](mailto:vptsales@vptpower.com)

All information contained in this datasheet is believed to be accurate, however, no responsibility is assumed for possible errors or omissions. The products or specifications contained herein are subject to change without notice.