



DATASHEET

VPT[®]

Power Your Critical Mission Today

VPT100+2800S SERIES

HIGH RELIABILITY COTS DC-DC CONVERTERS

Models Available

Input: 16 V to 40 V continuous, 50 V transient
 100 W, single output of 3.3 V, 5 V, 7 V, 12 V, 15 V, 28 V
 -55 °C to 105 °C Operation

1.0 DESCRIPTION

The VPT100+ series of isolated COTS DC-DC converters is a cost-effective solution for many demanding high reliability applications. A wide input voltage range accommodates nominal 28V inputs including avionics, mobile, ground systems, and other applications. A high efficiency design using synchronous rectification reduces input power requirements and eases thermal management. Low input and output ripple, fixed operating frequency, current sharing capability, and companion EMI filters simplify system design and compliance. A proven design heritage, no optoisolators and a rugged all metal package ensures long term reliability.

The VPT100+ series is intended for harsh environments including severe vibration, shock and temperature cycling. Testing is to JESD22, MIL-STD-810, and MIL-STD-883.

These converters are designed and manufactured in the USA in a facility certified to ISO9001, J-STD-001 and IPC-A-610.

This product may incorporate one or more of the following U.S. patents:

- 5,784,266
- 5,790,389
- 5,963,438
- 5,999,433
- 6,005,780
- 6,084,792
- 6,118,673



1.1 FEATURES

- High Reliability at Low Cost
- Parallel Up to 5 Units With Current Sharing
- Up to 100 Watts Maximum Output Power
- High Efficiency, Up to 91%
- Wide Input Voltage Range: 16 to 40 Volts per MIL-STD-704 and MIL-STD-1275
- High Input Transient Voltage: 50 Volts for 1 second
- Input Undervoltage Lockout
- Fixed Frequency
- Output Voltage Trim (+10% / -20%)
- Fast Startup time with Soft Start
- Current Limit Protection
- Short Circuit Protection
- Wide Temperature Range, -55 °C to 105 °C
- Internally Conformal Coated
- Standard Six-Sided Non-Hermetic Rugged Metal Package

1.2 COMPLIANCE

- MIL-STD-1275
- MIL-STD-704
- Meets MIL-STD-461 C-G when used with an appropriate VPT EMI filter

1.3 PACKAGING

- Low-profile: 2.350" x 1.550" x 0.465"
- Max weight: 76 g

1.4 SIMILAR PRODUCTS AND ACCESSORIES

- DVFL 120 W single output DC-DC Converter
- VXR100 100 W single output COTS DC-DC Converter
- VHR100 100 W single output COTS DC-DC Converter
- EMI filters, Thermal Pads, Front-End Modules and Accessories

2.0 DESCRIPTION

2.1 BLOCK DIAGRAM

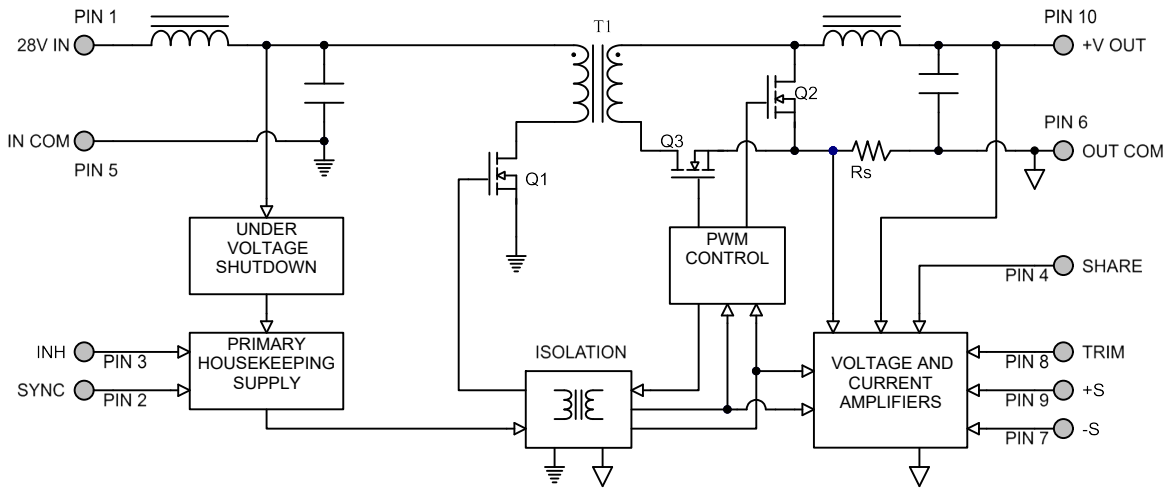

(Not applicable to VPT100+2828S)

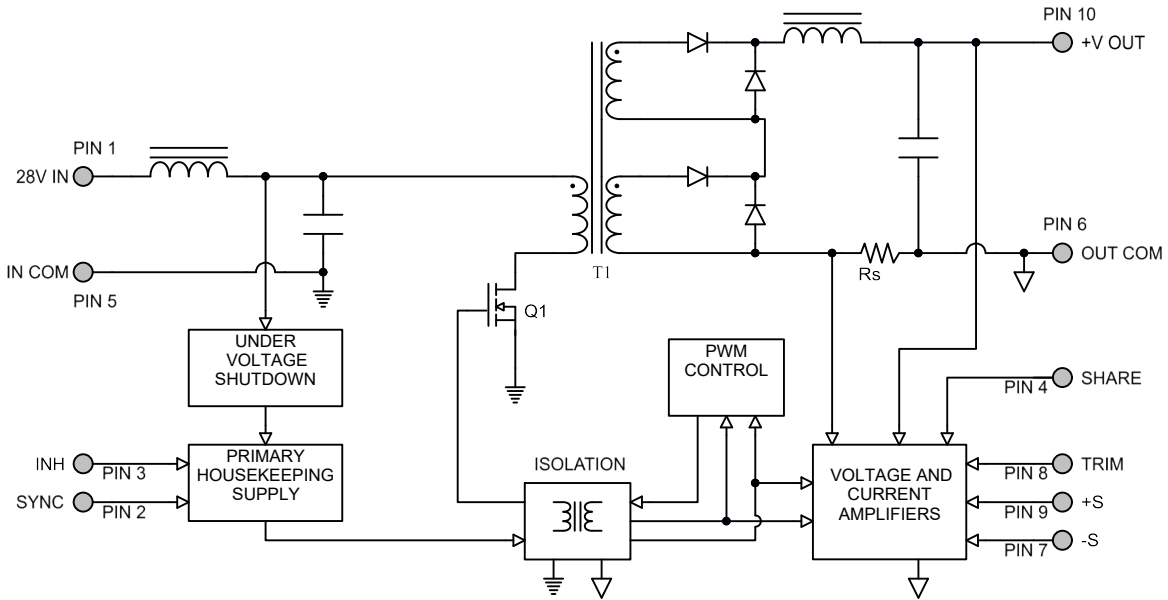

(Only applicable to VPT100+2828S)

2.2 CONNECTION DIAGRAM

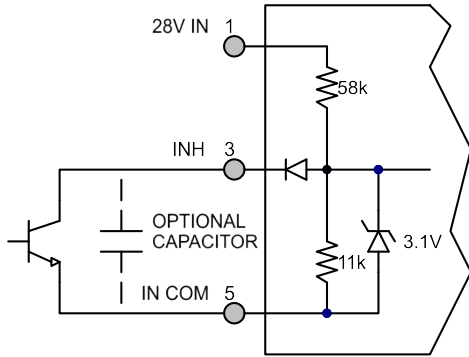
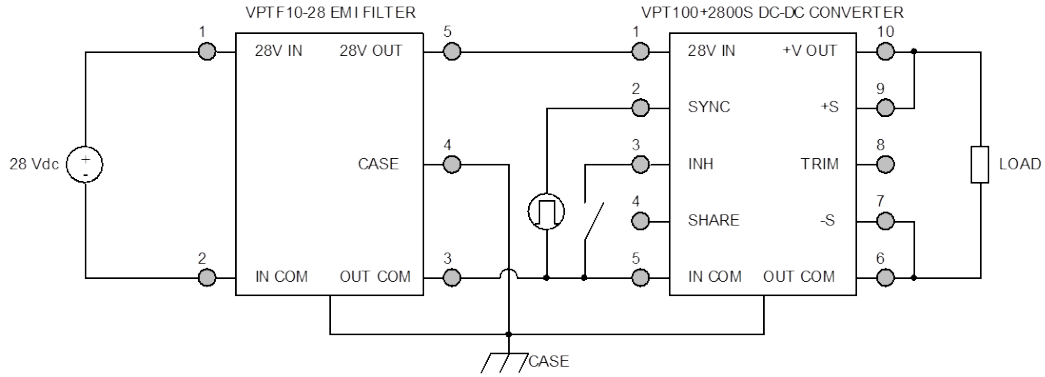

Inhibit Circuit (Shown with optional capacitor for turn-on delay)

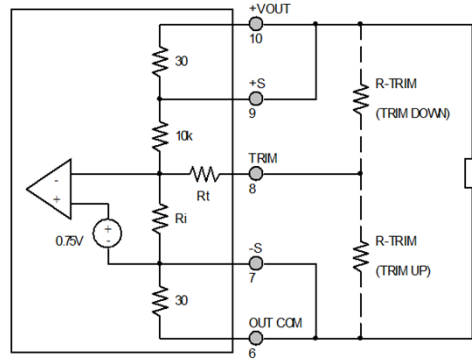

Output Voltage Trim Circuit

2.3 PARALLEL CONNECTION DIAGRAMS

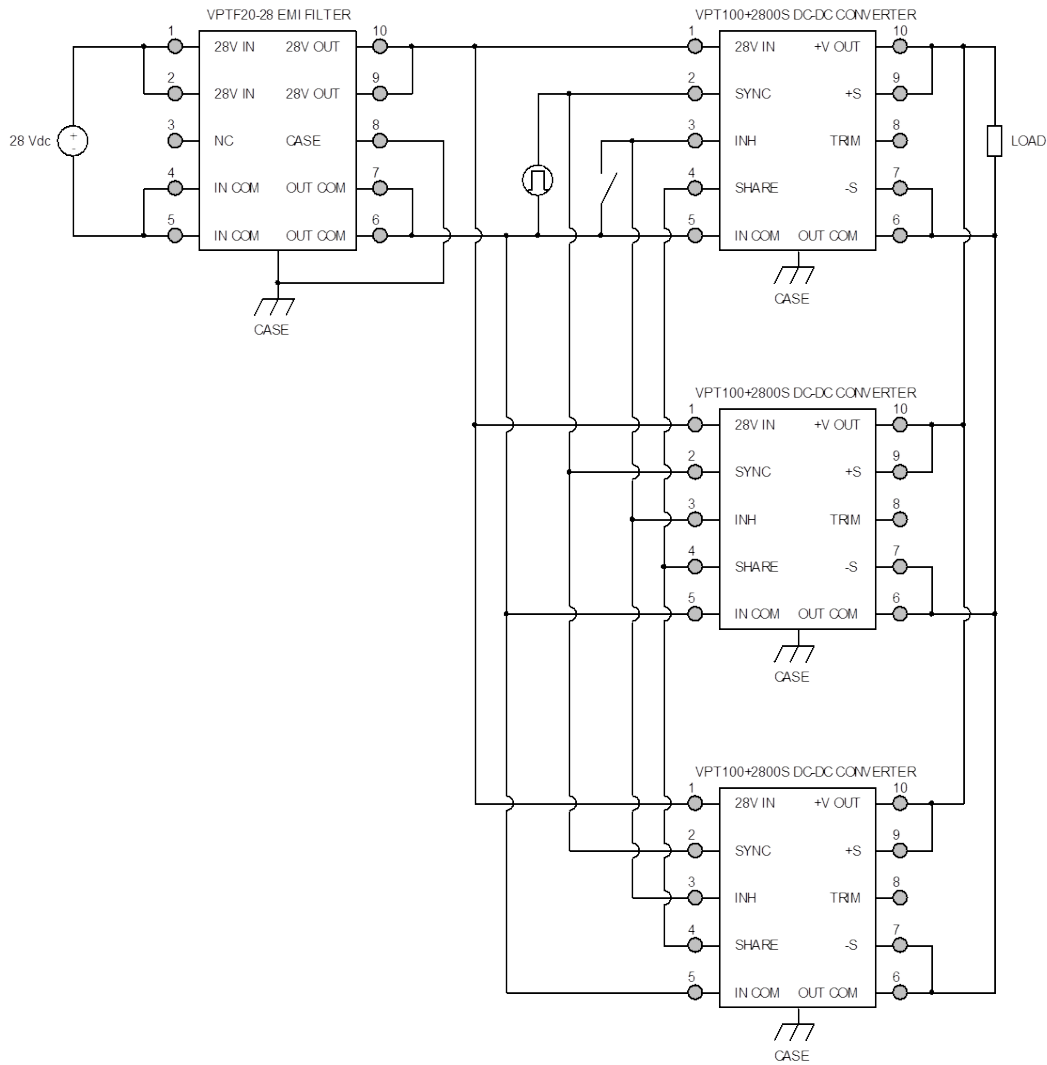

Current Sharing Parallel Connection for Multiple Converters (SYNC connection is optional)

Note: Units of the VPT100+ Series manufactured before Date Code 2301 cannot be shared with those manufactured after Date Code 2301 due to a share circuit design change. Please contact VPT Sales with any questions.

3.0 SPECIFICATIONS

3.1 ABSOLUTE MAXIMUM RATINGS

Absolute Maximum Ratings			
Input Voltage (Continuous):	40 V	Operating Temperature (Full Load):	-55 °C to 105 °C
Input Voltage (Transient, 1 second):	50 V	Storage Temperature:	-55 °C to 125 °C
		Lead Solder Temperature (10 seconds):	300 °C

3.2 PERFORMANCE SPECIFICATIONS

Tcase = -55 °C to 105 °C, Vin = +28 V ± 5%, Full Load, Unless Otherwise Specified

Parameter	Conditions	VPT100+283R3S			VPT100+2805S			Units
		Min	Typ	Max	Min	Typ	Max	
INPUT								
Voltage	Continuous	16	28	40	16	28	40	V
	Transient, 1 sec ³	-	-	50	-	-	50	V
Current	INH < 1.5 V	-	-	5	-	-	5	mA
	No Load	-	80	150	-	80	150	mA
Ripple Current	20 Hz to 10 MHz	-	-	180	-	-	200	mApp
Undervoltage Lockout	Turn On	14.5	-	15.8	14.5	-	15.8	V
	Turn Off ³	14	-	15	14	-	15	V
OUTPUT STATIC								
Voltage	Tcase = 25 °C	3.25	3.3	3.35	4.925	5	5.075	V
	Tcase = -55 °C to 105 °C	3.217	3.3	3.383	4.875	5	5.125	V
Power ²		0	-	66	0	-	100	W
Current ²		0	-	20	0	-	20	A
Ripple Voltage	20 Hz to 10 MHz	-	-	150	-	-	150	mVpp
Line Regulation	Vin = 16 V to 40 V	-	-	20	-	-	20	mV
Load Regulation	No Load to Full Load	-	-	50	-	-	50	mV
Load Fault Power Dissipation	Overload ³	-	-	24	-	-	24	W
	Short Circuit	-	-	24	-	-	24	W
OUTPUT DYNAMIC								
Load Step, Half to Full Load	Output Transient	-	-	250	-	-	250	mVpk
	Recovery ¹	-	-	300	-	-	300	µs
Line Step ³ , Vin = 16 V to 40 V	Output Transient	-	150	300	-	150	300	mVpk
	Recovery ¹	-	35	150	-	30	150	µs
Turn On, Vin = 0 to 28 V	Delay	-	4	10	-	4	10	ms
	Overshoot	-	0	15	-	0	25	mVpk
FUNCTION								
INH Pin Input ³	Output Inhibited	0	-	1.5	0	-	1.5	V
INH Pin Open Circuit Voltage ³	Output Enabled	-	3.1	14	-	3.1	14	V
Voltage Trim Range		-20	-	10	-20	-	10	%
SHARE Pin Voltage ³		0	-	8	0	-	8	V
Current Share Accuracy ³		-	5	-	-	5	-	%
SYNC Frequency Range	V _H - V _L = 5 V, D = 50%	240	-	325	240	-	325	kHz
GENERAL								
Efficiency		85	90	-	85	90	-	%
Capacitive Load ³		-	-	1000	-	-	1000	µF
Switching Frequency		230	260	290	230	260	290	kHz
Isolation	500 V DC, Tcase = 25 °C	100	-	-	100	-	-	MΩ
Weight		-	-	76	-	-	76	g
MTBF (MIL-HDBK-217F)	GM @ Tcase = 55 °C	-	393	-	-	393	-	kHr

1. Time for output voltage to settle within 1% of its nominal value.
2. Derate linearly to 0 at 115 °C.
3. Verified by initial electrical design verification. Post design verification, parameter shall be guaranteed to the limits specified.

3.2 PERFORMANCE SPECIFICATIONS (CONTINUED)

Tcase = -55 °C to 105 °C, Vin = +28 V ± 5%, Full Load, Unless Otherwise Specified

Parameter	Conditions	VPT100+2807S			VPT100+2812S			Units
		Min	Typ	Max	Min	Typ	Max	
INPUT								
Voltage	Continuous	16	28	40	16	28	40	V
	Transient, 1 sec ³	-	-	50	-	-	50	V
Current	INH < 1.5 V	-	-	5	-	-	5	mA
	No Load	-	100	200	-	130	200	mA
Ripple Current	20 Hz to 10 MHz	-	-	200	-	-	200	mApp
Undervoltage Lockout	Turn On	14.5	-	15.8	14.5	-	15.8	V
	Turn Off ³	14	-	15	14	-	15	V
OUTPUT STATIC								
Voltage	Tcase = 25 °C	6.895	7	7.105	11.82	12	12.18	V
	Tcase = -55 °C to 105 °C	6.825	7	7.175	11.7	12	12.3	V
Power ²		0	-	100	0	-	100	W
Current ²		0	-	14.28	0	-	8.33	A
Ripple Voltage	20 Hz to 10 MHz	-	-	150	-	-	150	mVpp
Line Regulation	Vin = 16 V to 40 V	-	-	20	-	-	20	mV
Load Regulation	No Load to Full Load	-	-	70	-	-	100	mV
Load Fault Power Dissipation	Overload ³	-	-	24	-	-	24	W
	Short Circuit	-	-	24	-	-	24	W
OUTPUT DYNAMIC								
Load Step, Half to Full Load	Output Transient	-	-	750	-	-	500	mVpk
	Recovery ¹	-	-	300	-	-	300	µs
Line Step ³ , Vin = 16 V to 40 V	Output Transient	-	200	750	-	110	300	mVpk
	Recovery ¹	-	35	150	-	-	150	µs
Turn On, Vin = 0 to 28 V	Delay	-	4	10	-	4	10	ms
	Overshoot	-	0	25	-	0	50	mVpk
FUNCTION								
INH Pin Input ³	Output Inhibited	0	-	1.5	0	-	1.5	V
INH Pin Open Circuit Voltage ³	Output Enabled	9	11	14	9	11	14	V
Voltage Trim Range		-20	-	10	-20	-	10	%
SHARE Pin Voltage ³		0	-	8	0	-	8	V
Current Share Accuracy ³		-	5	-	-	5	-	%
SYNC Frequency Range	V _H - V _L = 5 V, D = 50%	300	-	380	300	-	380	kHz
GENERAL								
Efficiency		87	90	-	87	90	-	%
Capacitive Load ³		-	-	1000	-	-	500	µF
Switching Frequency		300	340	380	300	340	380	kHz
Isolation	500 V DC, Tcase = 25 °C	100	-	-	100	-	-	MΩ
Weight		-	-	76	-	-	76	g
MTBF (MIL-HDBK-217F)	GM @ Tcase = 55 °C	-	393	-	-	393	-	kHr

1. Time for output voltage to settle within 1% of its nominal value.
2. Derate linearly to 0 at 115 °C.
3. Verified by initial electrical design verification. Post design verification, parameter shall be guaranteed to the limits specified.

3.2 PERFORMANCE SPECIFICATIONS (CONTINUED)

T_{case} = -55 °C to 105 °C, V_{in} = +28 V ± 5%, Full Load, Unless Otherwise Specified

Parameter	Conditions	VPT100+2815S			VPT100+2828S			Units
		Min	Typ	Max	Min	Typ	Max	
INPUT								
Voltage	Continuous	16	28	40	16	28	40	V
	Transient, 1 sec ³	-	-	50	-	-	50	V
Current	INH < 1.5 V	-	-	5	-	-	5	mA
	No Load	-	130	200	-	30	100	mA
Ripple Current	20 Hz to 10 MHz	-	-	200	-	-	200	mApp
Undervoltage Lockout	Turn On	14.5	-	15.8	14.5	-	15.8	V
	Turn Off ³	14	-	15	14	-	15	V
OUTPUT STATIC								
Voltage	T _{case} = 25 °C	14.775	15	15.225	27.44	28	28.56	V
	T _{case} = -55 °C to 105 °C	14.625	15	15.375	27.16	28	28.84	V
Power ²		0	-	100	0	-	100	W
Current ²		0	-	6.67	0	-	3.57	A
Ripple Voltage	20 Hz to 10 MHz	-	-	150	-	-	250	mVpp
Line Regulation	V _{in} = 16 V to 40 V	-	-	20	-	-	50	mV
Load Regulation	No Load to Full Load	-	-	100	-	-	100	mV
Load Fault Power Dissipation	Overload ³	-	-	24	-	-	24	W
	Short Circuit	-	-	24	-	-	28	W
OUTPUT DYNAMIC								
Load Step, Half to Full Load	Output Transient	-	-	500	-	-	1400	mVpk
	Recovery ¹	-	-	300	-	-	300	µs
Line Step ³ , V _{in} = 16 V to 40 V	Output Transient	-	150	300	-	300	1400	mVpk
	Recovery ¹	-	20	150	-	25	300	µs
Turn On, V _{in} = 0 to 28 V	Delay	-	4	10	-	4	10	ms
	Overshoot	-	0	50	-	0	50	mVpk
FUNCTION								
INH Pin Input ³	Output Inhibited	0	-	1.5	0	-	1.5	V
INH Pin Open Circuit Voltage ³	Output Enabled	-	3.1	14	-	3.1	14	V
Voltage Trim Range		-20	-	10	-20	-	10	%
SHARE Pin Voltage ³		0	-	8	0	-	8	V
Current Share Accuracy ³		-	5	-	-	5	-	%
SYNC Frequency Range	V _H - V _L = 5 V, D = 50%	300	-	380	300	-	380	kHz
GENERAL								
Efficiency		87	91	-	85	88	-	%
Capacitive Load ³		-	-	500	-	-	500	µF
Switching Frequency		300	340	380	300	340	380	kHz
Isolation	500 V DC, T _{case} = 25 °C	100	-	-	100	-	-	MΩ
Weight		-	-	76	-	-	76	g
MTBF (MIL-HDBK-217F)	GM @ T _{case} = 55 °C	-	393	-	-	393	-	kHr

1. Time for output voltage to settle within 1% of its nominal value.
2. Derate linearly to 0 at 115 °C.
3. Verified by initial electrical design verification. Post design verification, parameter shall be guaranteed to the limits specified.



4.0 PERFORMANCE CURVES

Tcase = 25° C, Full Load, Unless Otherwise Specified

4.1 EFFICIENCY PERFORMANCE CURVES

4.1.1 VPT100+283R3S Efficiency (%) vs. Output Power (W)

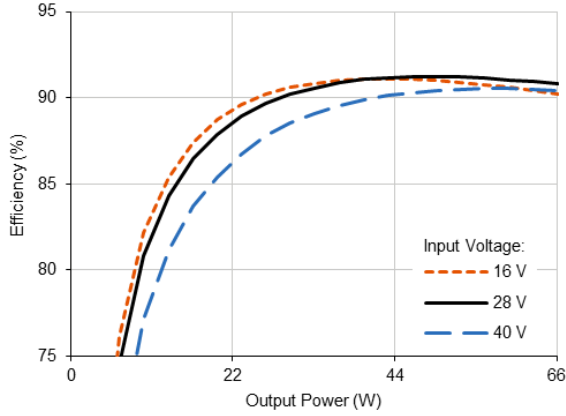

4.1.2 VPT100+2805S Efficiency (%) vs. Output Power (W)

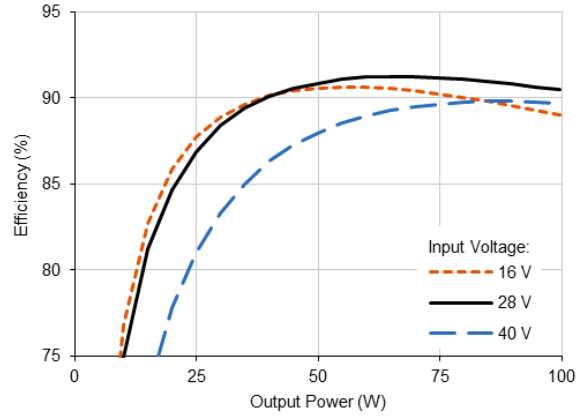

4.1.3 VPT100+2807S Efficiency (%) vs. Output Power (W)

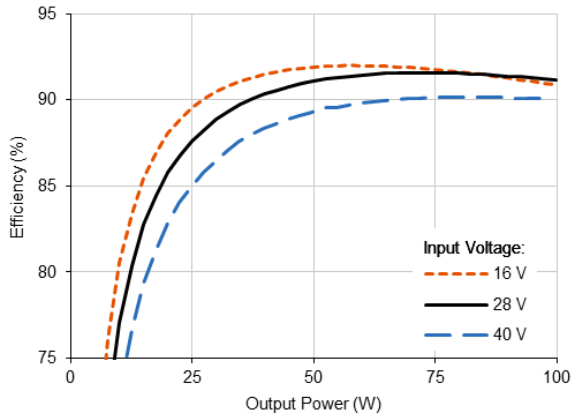

4.1.4 VPT100+2812S Efficiency (%) vs. Output Power (W)

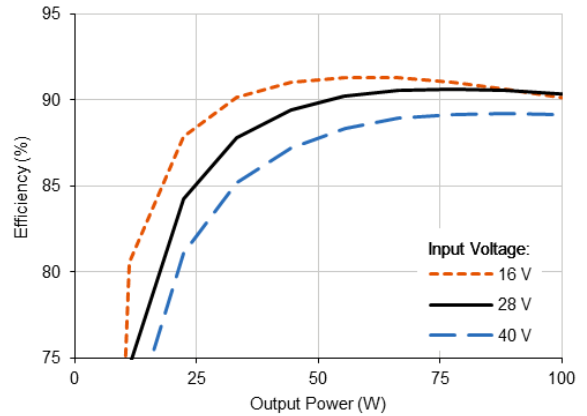

4.1.5 VPT100+2815S Efficiency (%) vs. Output Power (W)

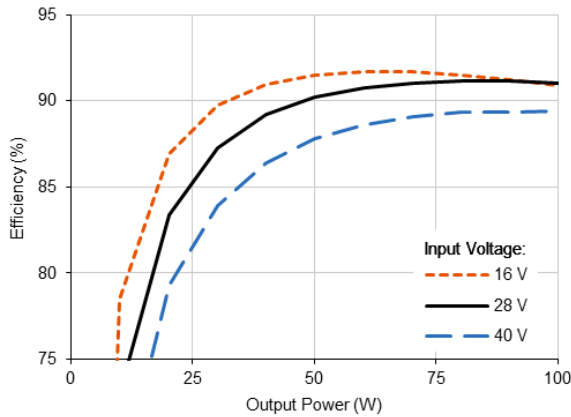

4.1.6 VPT100+2828S Efficiency (%) vs. Output Power (W)

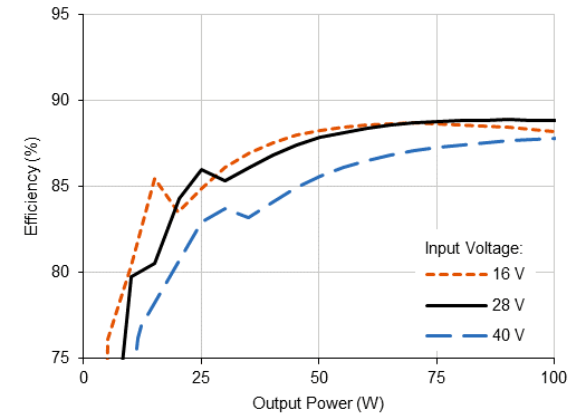

5.0 MECHANICAL OUTLINES AND PINOUT

Standard Package:

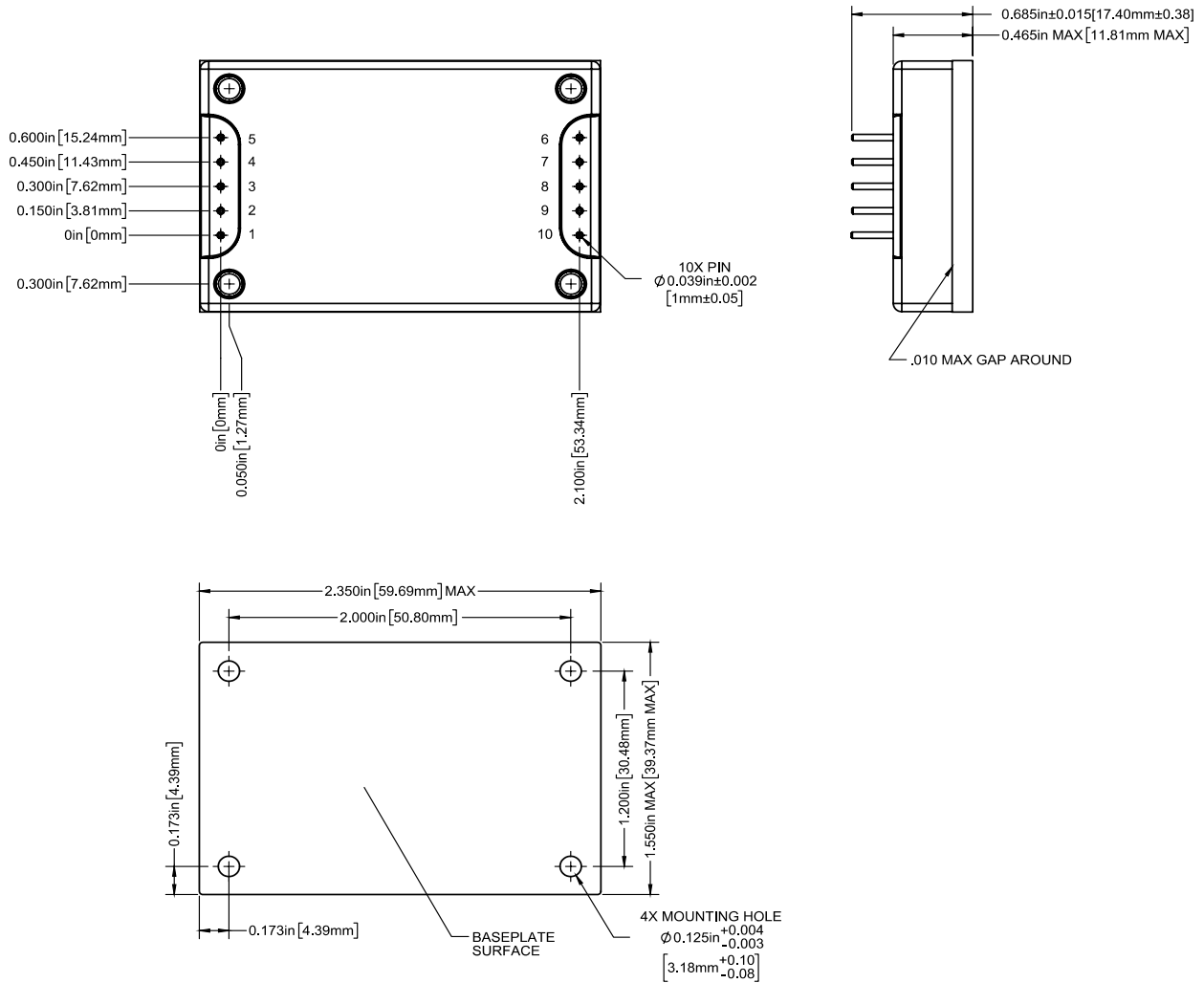

1. Case temperature is measured on the center of the baseplate surface.
2. Materials: Baseplate (Aluminum, conductive conversion coating); Cover (Brass, Nickel Plated); Pins (Copper, gold over nickel plating)
3. Mounting holes are not threaded. Recommended fastener is 4-40
4. This Package is not hermetic.
5. Tolerances are ±0.005" unless otherwise stated.

Pin	Function	Pin	Function
1	28VIN	6	OUTCOM
2	SYNC	7	-SENSE
3	INHIBIT	8	TRIM
4	SHARE	9	+SENSE
5	INCOM	10	+VOUT

6.0 PACKAGE PIN DESCRIPTION

Pin	Function	Description
1	28VIN	Positive Input Voltage Connection
2	SYNC	Input Synchronization Signal. TTL squarewave, 5 Vpp, 20 - 80% duty cycle.
3	INHIBIT	This is an open collector input. Logic Low = Disabled Output. Connect the inhibit pin to input common to disable the output. Unconnected, open collector or open drain = Enabled Output.
4	SHARE	Current Share Connection
5	INCOM	Input Return Connection
6	OUTCOM	Output Return Connection
7	-SENSE	Output Return Remote Sense. Compensate for up to 0.5 V total drop (positive and return).
8	TRIM	Trim Output Voltage to +10%, -20% of Nominal Value. Leave open if not used.
9	+SENSE	Positive Output Voltage Remote Sense. Compensate for up to 0.5 V total drop (positive and return).
10	+VOUT	Positive Output Voltage Connection

7.0 OUTPUT VOLTAGE TRIM

The output voltage can be trimmed down by connecting a resistor between the TRIM pin and the +VOUT pin, or can be trimmed up by connecting a resistor between the TRIM pin and the OUTCOM pin as shown in Section 2.2. The maximum trim range is +10% up and -20% down. The appropriate resistor values versus the output voltage are given in the trim table below.

VPT100+283R3S		VPT100+2805S		VPT100+2807S		VPT100+2812S		VPT100+2815S		VPT100+2828S	
+Vout (V)	Rtrim (Ω)	+ Vout (V)	Rtrim (Ω)	+ Vout (V)	Rtrim (Ω)	+ Vout (V)	Rtrim (Ω)	+ Vout (V)	Rtrim (Ω)	+ Vout (V)	Rtrim (Ω)
3.60	3.94k	5.5	980	7.7	714	13.2	1.14k	16.50	686	30.5	720
3.55	8.92k	5.4	4.72k	7.5	5.00k	13.0	2.39k	16.25	1.69k	30.0	1.46k
3.50	16.4k	5.3	10.9k	7.3	15.0k	12.8	4.26k	16.00	3.19k	29.5	2.68k
3.45	28.8k	5.2	23.4k	7.1	65.0k	12.6	7.39k	15.75	5.7k	29.0	5.12k
3.40	53.5k	5.1	60.5k	7.0	—	12.4	13.6k	15.50	10.7k	28.5	12.3k
3.35	127k	5.0	—	6.9	605k	12.2	32.4k	15.25	25.9k	28.0	—
3.30	—	4.9	404k	6.7	188k	12.0	—	15.00	—	27.5	551k
3.25	486k	4.8	189k	6.5	105k	11.8	548k	14.75	552k	27.0	265k
3.20	226k	4.7	118k	6.3	69.3k	11.6	266k	14.50	270k	26.5	171k
3.15	140k	4.6	82.4k	6.1	49.4k	11.4	172k	14.25	175k	26.0	125k
3.10	96.9k	4.5	61.1k	5.9	36.8k	11.2	126k	14.00	128k	25.5	97.4k
3.05	71.3k	4.4	46.9k	5.7	28.1k	11.0	97.4k	13.75	99.5k	25.0	79k
3.00	54.2k	4.3	36.8k	5.6	24.6k	10.8	78.6k	13.50	80.6k	24.5	65.9k
2.95	42k	4.2	29.2k			10.6	65.3k	13.25	67k	24.0	56.1k
2.90	32.8k	4.1	23.3k			10.4	55.2k	13.00	56.9k	23.5	48.5k
2.85	25.7k	4.0	18.5k			10.2	47.4k	12.75	49k	23.0	42.4k
2.80	20.1k					10.0	41.1k	12.50	42.6k	22.5	37.4k
2.75	15.4k					9.8	36k	12.25	37.5k		
2.70	11.5k					9.6	31.8k	12.00	33.2k		
2.65	8.26k										



8.0 ENVIRONMENTAL SCREENING

Screening	Condition
Internal Visual	IPC-A-610, Class 3
Temperature Cycling	MIL-STD-883, Method 1010, Condition B, -55°C to +125°C, 10 Cycles
Burn-In	96 hours at +105°C
Final Electrical	100% at 25 °C
External Visual	Internal Procedure

9.0 ORDERING INFORMATION

VPT100+	28	05	S
1	2	3	4

(1) Product Series	(2) Nominal Input Voltage	(3) Output Voltage	(4) Number of Outputs
VPT100+	28	28 Volts	Single
		3R3 3.3 Volts	
		05 5 Volts	
		07 7 Volts	
		12 12 Volts	
		15 15 Volts	
		28 28 Volts	

Please contact your sales representative or the VPT Inc. Sales Department for more information concerning additional environmental screening and testing, different input voltage, output voltage, power requirements, and source inspection.

10.0 CONTACT INFORMATION

To request a quotation or place orders please contact your sales representative or the VPT, Inc. Sales Department at:

Phone: (425) 353-3010
Fax: (425) 353-4030
E-mail: vptsales@vptpower.com

All information contained in this datasheet is believed to be accurate, however, no responsibility is assumed for possible errors or omissions. The products or specifications contained herein are subject to change without notice. VPT, its logo and tagline are registered trademarks in the U.S. Patent and Trademark Office.

11.0 ADDITIONAL INFORMATION

Visit the VPT website for additional technical resources, including:

[Product Literature](#)



[Application Notes and White Papers](#)

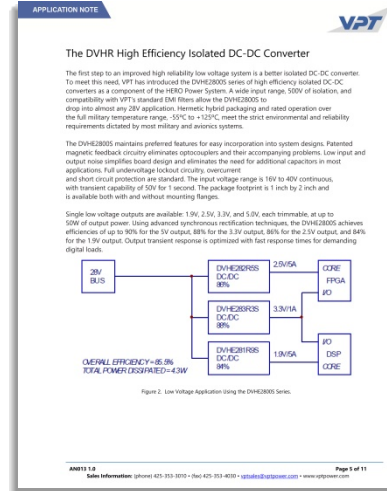

[Technical Video Labs](#)



[Additional Products For Avionics/Military, Hi-Temp, Hi-Rel COTS, and Space Applications](#)

