



DATASHEET



Power Your Critical Mission Today

VPT30-2800T SERIES HIGH RELIABILITY COTS DC-DC CONVERTERS

Models Available

Input: 9 V to 80 V continuous, 100 V transient
30 W, triple outputs of 3.3 V, 5 V, 12 V, 15 V
-55 °C to 105 °C Operation

1.0 DESCRIPTION

The VPT30 series of isolated COTS DC-DC converters is a cost-effective solution for many demanding high reliability applications. A wide input voltage range accommodates nominal 28V inputs including avionics, mobile, ground systems, and other applications. Low input and output ripple, fixed operating frequency, and companion EMI filters simplify system design and compliance. A proven design heritage, no optoisolators and a rugged all metal or optional epoxy encapsulated package ensure long term reliability.

The VPT30 series is intended for harsh environments including severe vibration, shock and temperature cycling. Testing is to JESD22, MIL-STD-810, and MIL-STD-883.

These converters are designed and manufactured in a facility certified to ISO9001, J-STD-001 and IPC-A-610.

This product may incorporate one or more of the following U.S. patents:

- 5,784,266
- 5,790,389
- 5,963,438
- 5,999,433
- 6,005,780
- 6,084,792
- 6,118,673

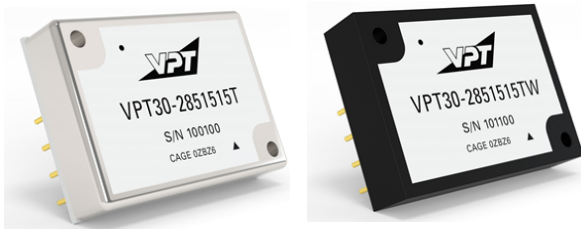

1.1 FEATURES

- High Reliability at Low Cost
- 30 Watts Output Power
- Three Independent Fully Isolated Outputs
- Wide Input Voltage Range: 9 to 80 Volts per MIL-STD-704 and MIL-STD-1275
- High Input Transient Voltage: 100 Volts for 1 sec per MIL-STD-1275
- Each Output can be configured as a Positive or Negative Output
- Zero Cross Regulation
- No Minimum Load Requirement
- Input Undervoltage Lockout
- Fixed Frequency
- Output Soft Start
- Short Circuit Protection
- Magnetic Feedback, no Optoisolators
- Wide Temperature Range, -55 °C to 105 °C
- Internally Conformal Coated
- Standard Six-Sided Non-Hermetic Rugged Metal Package
- Multiple standard output voltage combinations
- Optional Six-Sided Rugged Epoxy Encapsulated V-SHIELD® Package with Integral Metalized EMI shield that is fully compatible with aqueous cleaning processes

1.2 COMPLIANCE

- MIL-STD-1275
- MIL-STD-704
- Meets MIL-STD-461 C-G when used with an appropriate VPT EMI filter

1.3 PACKAGING

- Low-profile: 1.885" x 1.325" x 0.400"
- Optional Rugged Epoxy Encapsulated V-SHIELD® Package
- Max weight: 50 g

1.4 SIMILAR PRODUCTS AND ACCESSORIES

- DVTR 30 W triple output DC-DC Converter
- VHR30 30 W triple output COTS DC-DC Converter
- EMI filters, Thermal Pads, Front-End Modules and Accessories

2.0 DESCRIPTION

2.1 BLOCK DIAGRAM

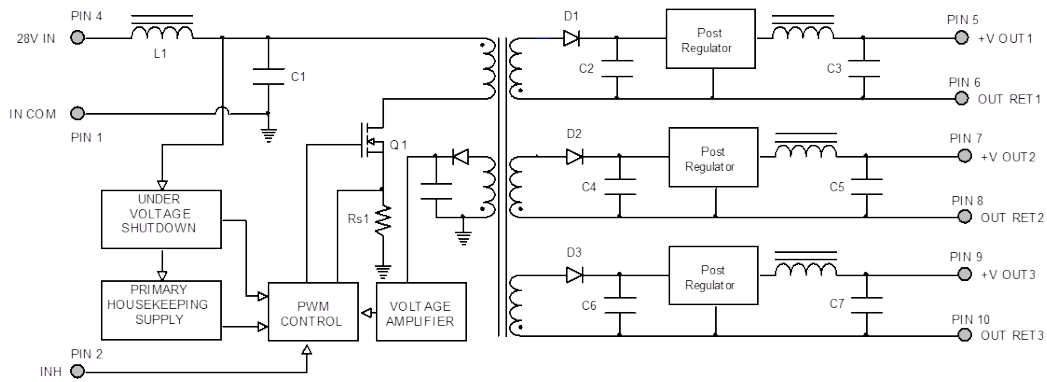

2.2 CONNECTION DIAGRAM

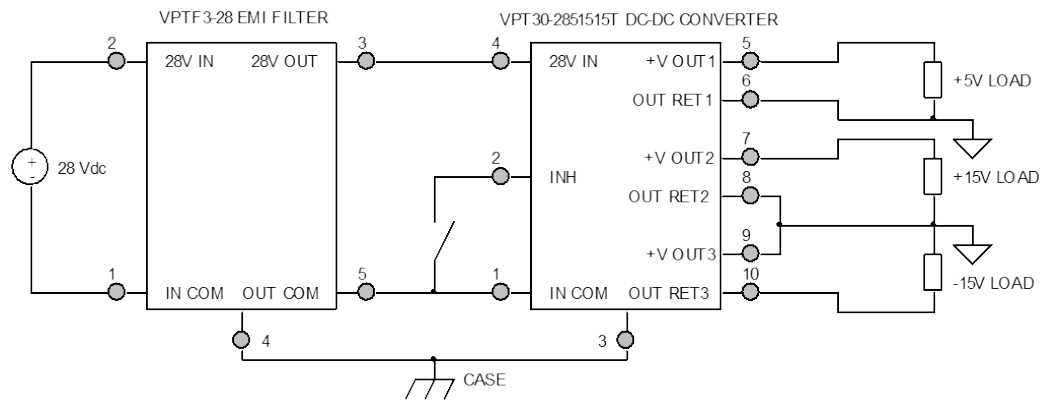

(Shown with optional VPTF3-28 EMI filter, recommended for input voltages > 13V, and optional negative output configuration.)

2.2 CONNECTION DIAGRAMS (CONTINUED)

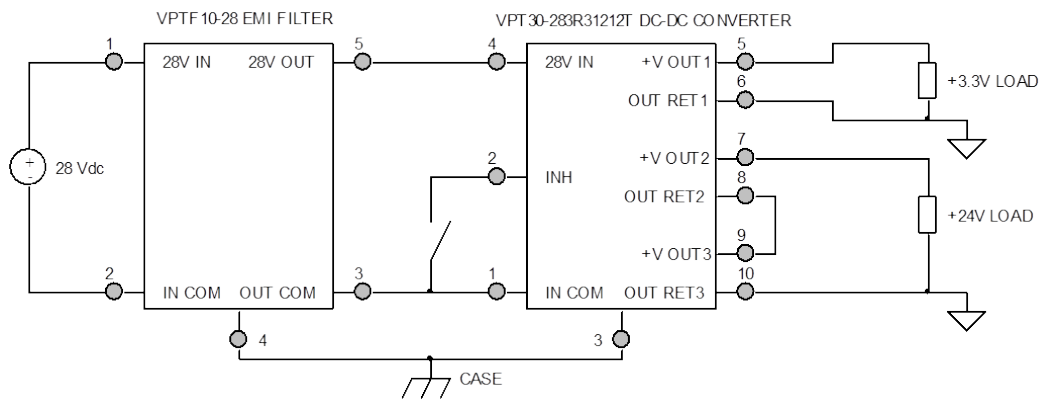

(Shown with optional VPTF10-28 EMI filter, recommended for input voltages < 13V, and optional stacked output configuration.)

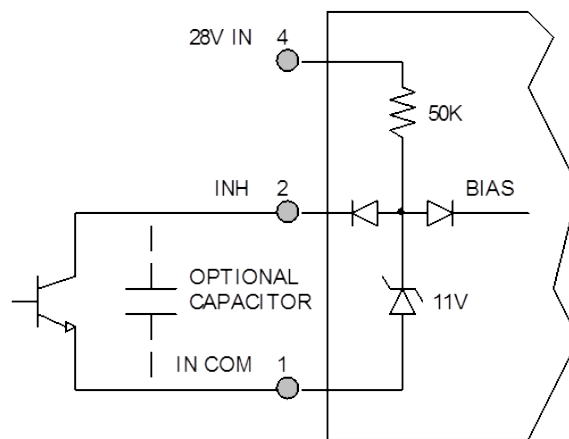

Inhibit Circuit (Shown with optional capacitor for turn-on delay)

3.0 SPECIFICATIONS

3.1 ABSOLUTE MAXIMUM RATINGS

Absolute Maximum Ratings

Input Voltage (Continuous):	80 V	Operating Temperature (Full Load):	-55 °C to 105 °C
Input Voltage (Transient, 1 sec):	100 V	Storage Temperature:	-55 °C to 125 °C
		Lead Solder Temperature (10 seconds):	300 °C

3.2 PERFORMANCE SPECIFICATIONS

Tcase = -55 °C to 105 °C, Vin = +28 V ± 5%, Full Load, Unless Otherwise Specified

VPT30-2800T					
Parameter	Conditions	Min	Typ	Max	Units
INPUT					
Voltage	Continuous ⁴	9	28	80	V
	Transient, 1 sec ³	-	-	100	V
Current	INH < 1.5 V	-	1	5	mA
	No Load	-	90	130	mA
Ripple Current ⁵	20 Hz to 10 MHz	-	30	90	mA
Undervoltage Lockout	Turn On	9.8	-	11	V
	Turn Off ³	8	-	8.9	V
OUTPUT STATIC					
Power ²		0	-	30	W
Load Fault Power Dissipation	Short Circuit	-	2	5	W
FUNCTION					
Inhibit Pin Input ³	Output Inhibited	0	-	1.5	V
Inhibit Pin Open Circuit Voltage ³	Output Enabled	9	11	13	V
GENERAL					
Efficiency ⁵		77	82	-	%
Switching Frequency	Input	400	500	550	kHz
	Output	325	400	475	kHz
Isolation Input / Output / Case	500 V DC, Tcase = 25 °C	100	-	-	MΩ
Isolation Output / Output	100 V DC, Tcase = 25 °C	20	-	-	MΩ
Weight		-	-	50	g
MTBF (MIL-HDBK-217F)	GM @ Tcase = 55 °C		672		kHr

Parameter	Conditions	3.3 V Output			5 V Output			Units
		Min	Typ	Max	Min	Typ	Max	
OUTPUT STATIC								
Voltage	Tcase = 25 °C	3.25	3.3	3.35	4.92	5	5.08	V
	Tcase = -55 °C to 105 °C	3.21	3.3	3.38	4.87	5	5.13	V
Power ²		0	-	10	0	-	15	W
Current ²		0	-	3	0	-	3	A
Ripple Voltage	20 Hz to 10 MHz	-	40	100	-	40	100	mVpp
Line Regulation ⁵	Vin = 9 V to 80 V	-	2	20	-	2	20	mV
Load Regulation	No Load to Full Load	-	3	30	-	3	30	mV
OUTPUT DYNAMIC								
Load Step, Half to Full Load	Output Transient	-	140	280	-	100	200	mVpk
	Recovery ¹	-	120	240	-	90	180	μs
Line Step ^{3, 5} , Vin = 16 V to 40 V	Output Transient	-	50	100	-	60	120	mVpk
	Recovery ¹	-	50	100	-	50	100	μs
Turn On ⁵ , Vin = 0 to 28 V	Delay	-	14	20	-	14	20	ms
	Overshoot	-	0	15	-	0	25	mVpk
GENERAL								
Capacitive Load ³		-	-	1000	-	-	1000	μF

1. Time for output voltage to settle to within 1% of its nominal value.
2. Derate linearly to 0 at 115 °C.
3. Verified by initial electrical design verification. Post design verification, parameter shall be guaranteed to the limits specified.
4. Operation down to 9 V is possible after the input voltage is taken above 11 V to start the module.
5. Tested with a balanced full load of 10 W per each output.

3.2 PERFORMANCE SPECIFICATIONS (CONTINUED)

T_{case} = -55 °C to 105 °C, V_{in} = +28 V ± 5%, Full Load, Unless Otherwise Specified

Parameter	Conditions	12 V Output			15 V Output			Units
		Min	Typ	Max	Min	Typ	Max	
OUTPUT STATIC								
Voltage	T _{case} = 25 °C	11.82	12	12.18	14.77	15	15.23	V
	T _{case} = -55 °C to 105 °C	11.7	12	12.3	14.62	15	15.38	V
Power ²		0	-	15	0	-	15	W
Current ²		0	-	1.25	0	-	1	A
Ripple Voltage	20 Hz to 10 MHz	-	40	100	-	40	100	mVpp
Line Regulation ⁵	V _{in} = 9 V to 80 V	-	2	20	-	2	20	mV
Load Regulation	No Load to Full Load	-	3	30	-	3	30	mV
OUTPUT DYNAMIC								
Load Step, Half to Full Load	Output Transient	-	120	240	-	110	220	mVpk
	Recovery ¹	-	0	100	-	0	100	μs
Line Step ^{3, 5} , V _{in} = 16 V to 40 V	Output Transient	-	150	300	-	180	360	mVpk
	Recovery ¹	-	50	100	-	50	100	μs
Turn On ⁵ , V _{in} = 0 to 28 V	Delay	-	14	20	-	14	20	ms
	Overshoot	-	0	50	-	0	50	mVpk
GENERAL								
Capacitive Load ³		-	-	500	-	-	500	μF

1. Time for output voltage to settle to within 1% of its nominal value.
2. Derate linearly to 0 at 115 °C.
3. Verified by initial electrical design verification. Post design verification, parameter shall be guaranteed to the limits specified.
4. Operation down to 9 V is possible after the input voltage is taken above 11 V to start the module.
5. Tested with a balanced full load of 10 W per each output.



4.0 PERFORMANCE CURVES

4.1 EFFICIENCY PERFORMANCE CURVES

T_{case} = 25 °C, Full Load, Unless Otherwise Specified

4.1.1 VPT30-283R31212T Efficiency (%) vs. Output Power (W)

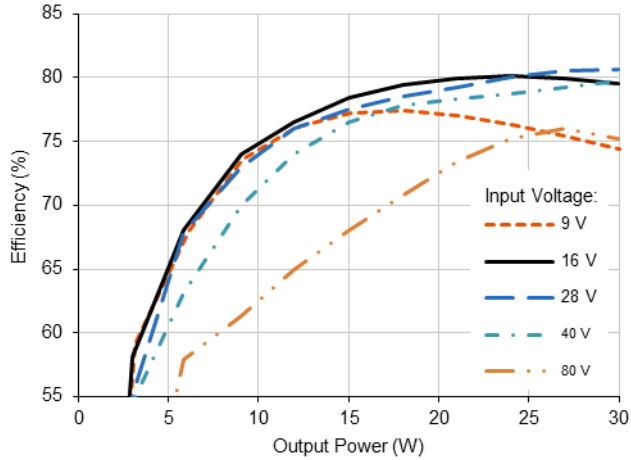

4.1.2 VPT30-2851515T Efficiency (%) vs. Output Power (W)

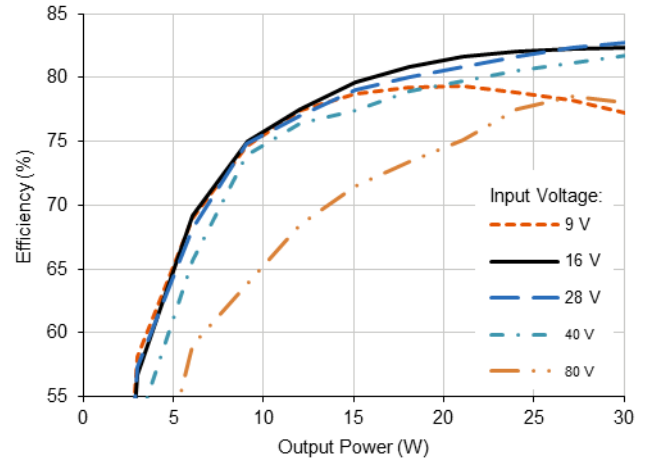

5.0 MECHANICAL OUTLINES AND PINOUT

Standard Metal Package:

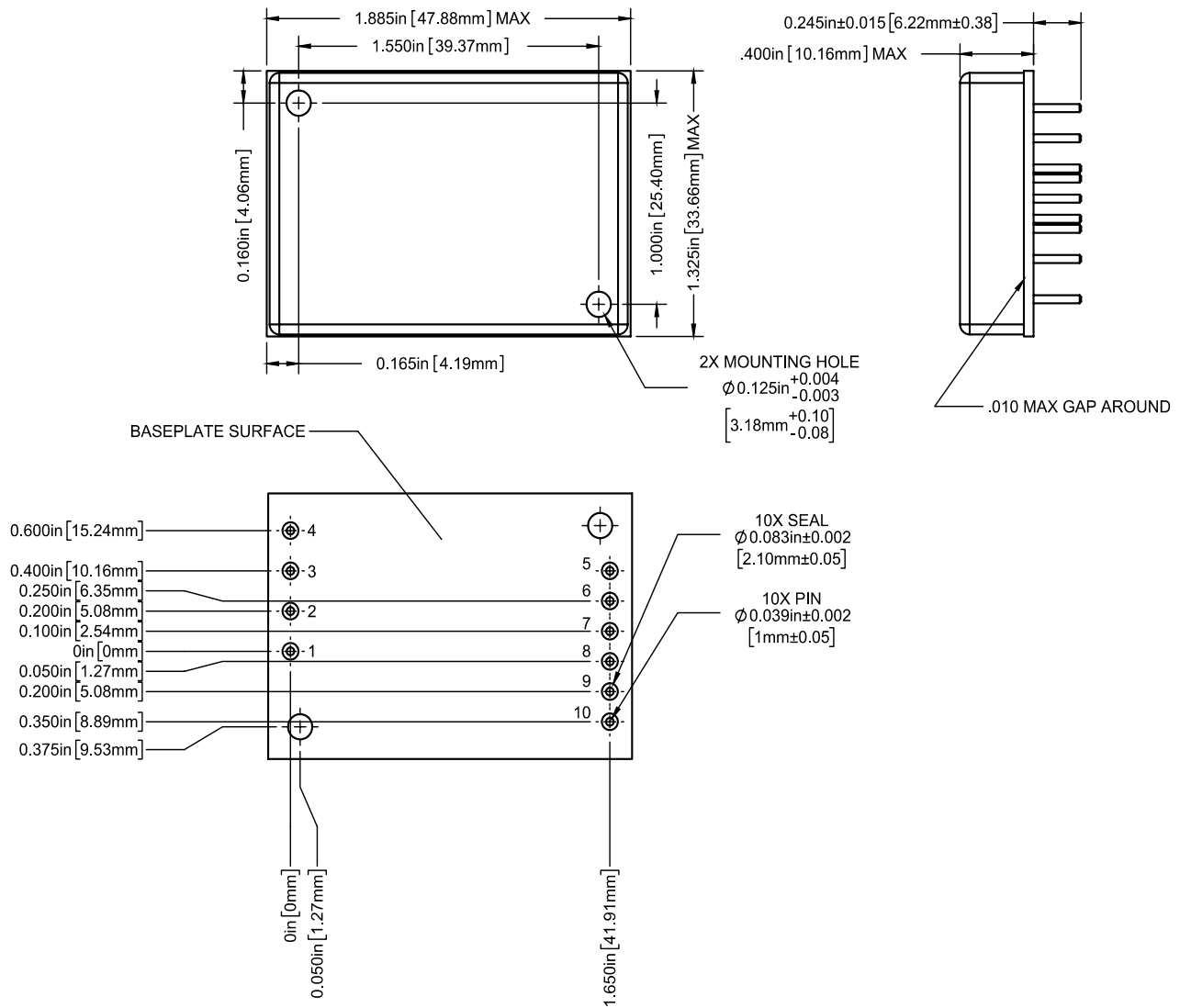

- Case temperature is measured on the center of the baseplate surface.
- Materials: Baseplate (Aluminum, conductive conversion coating); Cover (Nickel Plated); Pins (Copper, gold over nickel plating)
- Mounting holes are not threaded. Recommended fastener is 4-40
- This Package is not hermetic.
- Tolerances are $\pm 0.005"$ unless otherwise stated.

Pin	Function	Pin	Function
1	INCOM	6	OUTRET1
2	INHIBIT	7	+VOUT2
3	CASE	8	OUTRET2
4	28V IN	9	+VOUT3
5	+VOUT1	10	OUTRET3

5.0 MECHANICAL OUTLINES AND PINOUT (CONTINUED)

Optional Epoxy Encapsulated Package:

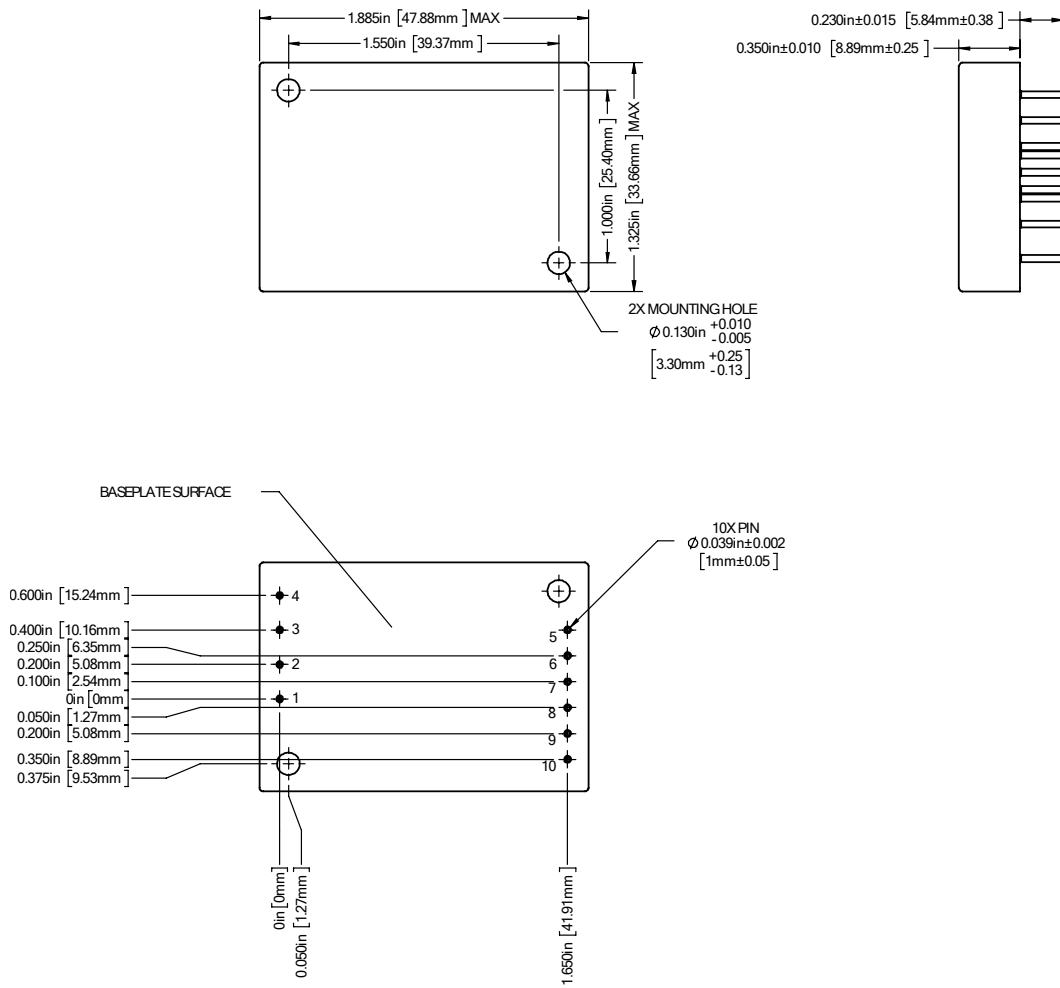

1. Tolerances are ±0.010" unless otherwise stated
2. Case temperature is measured on the center of the baseplate surface
3. Mounting holes are not threaded. Recommended fastener is 4-40
4. Materials: Body (Epoxy with integral metalized EMI shield); Pin (Tellurim Copper, alloy 145, gold over nickel plating)

Pin	Function	Pin	Function
1	INCOM	6	OUTRET1
2	INHIBIT	7	+VOUT2
3	CASE	8	OUTRET2
4	28V IN	9	+VOUT3
5	+VOUT1	10	OUTRET3



6.0 PACKAGE PIN DESCRIPTION

Pin	Function	Description
1	INCOM	Input Return Connection.
2	INHIBIT	This is an open collector input. Logic Low = Disabled Output. Connect the inhibit pin to input common to disable the output. Unconnected, open collector or open drain = Enabled Output.
3	CASE	Case Connection.
4	28VIN	Positive Input Voltage Connection.
5	+VOUT1	Positive Output 1 Voltage Connection.
6	OUTRET1	Output Return 1 Connection.
7	+VOUT2	Positive Output 2 Voltage Connection.
8	OUTRET2	Output Return 2 Connection.
9	+VOUT3	Positive Output 3 Voltage Connection.
10	OUTRET3	Output Return 3 Connection.

7.0 ENVIRONMENTAL SCREENING

Screening	Condition
Internal Visual	IPC-A-610, Class 3
Temperature Cycling	MIL-STD-883, Method 1010, Condition B, -55°C to +125°C, 10 Cycles
Burn-In	96 hours at +105°C
Final Electrical	100% at 25 °C
External Visual	Internal Procedure

8.0 ORDERING INFORMATION

VPT30-	28	5	15	15	T	W
1	2	3	4	5	6	7

(1) Product Series	(2) Nominal Input Voltage	(3) Output 1	(4) Output 2	(5) Output 3	(6) Number of Outputs	(7) Package Option
VPT30-	28	28 Volts	3R3 3.3 Volts 5 5 Volts	5 5 Volts 12 12 Volts 15 15 Volts	12 12 Volts 15 15 Volts	T Triple None W Standard Metal Epoxy Encapsulated

Please contact your sales representative or the VPT Inc. Sales Department for more information concerning additional environmental screening and testing, different input voltage, output voltage, power requirements, and source inspection.

9.0 CONTACT INFORMATION

To request a quotation or place orders please contact your sales representative or the VPT, Inc. Sales Department at:

Phone: (425) 353-3010
Fax: (425) 353-4030
E-mail: vptsales@vptpower.com

All information contained in this datasheet is believed to be accurate, however, no responsibility is assumed for possible errors or omissions. The products or specifications contained herein are subject to change without notice. VPT, its logo and tagline are registered trademarks in the U.S. Patent and Trademark Office.

10.0 ADDITIONAL INFORMATION

Visit the VPT website for additional technical resources, including:

[Product Literature](#)



[Application Notes and White Papers](#)

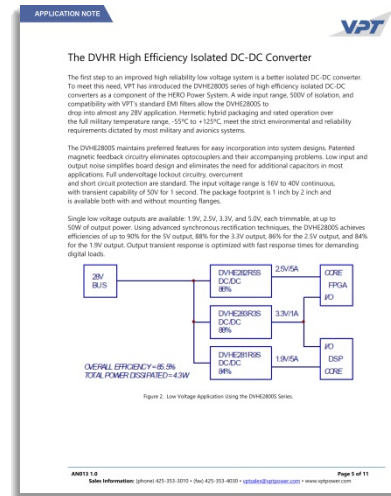

[Technical Video Labs](#)



[Additional Products For Avionics/Military, Hi-Temp, Hi-Rel COTS, and Space Applications](#)

