

VPT5-2800S Series

HIGH RELIABILITY COTS DC-DC CONVERTERS

DESCRIPTION

The VPT5 series of isolated COTS DC-DC converters is a cost-effective solution for many demanding high reliability applications. A wide input voltage range accommodates nominal 28V inputs including avionics, mobile, ground systems, and other applications. Low input and output ripple, fixed operating frequency, and companion EMI filters simplify system design and compliance. A proven design heritage, no optoisolators and a rugged all metal package ensure long term reliability.

The VPT5 series is intended for harsh environments including severe vibration, shock and temperature cycling. Testing is to JESD22, MIL-STD-810, and MIL-STD-883.

These converters are designed and manufactured in a facility certified to ISO9001, J-STD-001 and IPC-A-610.

This product may incorporate one or more of the following U.S. patents:

5,784,266
5,790,389
5,963,438
5,999,433
6,005,780
6,084,792
6,118,673

FEATURES

- High Reliability at Low Cost
- 5 Watts Output Power
- Wide Input Voltage Range: 15 to 50 Volts per MIL-STD-704 and MIL-STD-1275
- High Input Transient Voltage: 80 Volts for 1 sec per MIL-STD-704A
- Input Undervoltage Lockout
- Fixed Frequency
- Output Soft Start
- Current Limit Protection
- Short Circuit Protection
- Magnetic Feedback, no Optoisolators
- Wide Temperature Range, -55°C to 105°C
- Internally Conformal Coated
- Standard Six-Sided Non-Hermetic Rugged Metal Package
- Meets MIL-STD-461 Revisions C-G EMC Requirements When Used With VPT's EMI Filters.



Figure 1 – VPT5-2800S DC-DC Converter

(Not to Scale)

SPECIFICATIONS (T_{CASE} = -55°C to +105°C, V_{IN} = +28V ± 5%, Full Load, Unless Otherwise Specified)

ABSOLUTE MAXIMUM RATINGS

Input Voltage (Continuous)	50 V _{DC}	Junction Temperature Rise to Case	+10°C
Input Voltage (Transient, 1 second)	80 Volts	Storage Temperature	-55°C to +125°C
Output Power ¹	5 Watts	Lead Solder Temperature (10 seconds)	300°C
Power Dissipation (Full Load, T _{CASE} = +105°C)	3 Watts	Weight (Maximum)	22 Grams

Parameter	Conditions	VPT5-283R3S			VPT5-2805S			Units
		Min	Typ	Max	Min	Typ	Max	
STATIC								
INPUT Voltage ⁴	Continuous	15	28	50	15	28	50	V
	Transient, 1 sec	-	-	80	-	-	80	V
Current	Inhibited	-	4	6	-	4	6	mA
	No Load	-	40	60	-	40	60	mA
Ripple Current	Full Load, 20Hz to 10MHz	-	30	50	-	30	50	mA _{p-p}
Inhibit Pin Input ⁴		0	-	1.5	0	-	1.5	V
Inhibit Pin Open Circuit Voltage ⁴		9.0	11.0	13.0	9.0	11.0	13.0	V
UVLO Turn On		12.0	-	14.8	12.0	-	14.8	V
UVLO Turn Off ⁴		11.0	-	14.5	11.0	-	14.5	V
OUTPUT Voltage	V _{OUT} T _{CASE} = 25°C	3.25	3.30	3.35	4.92	5.00	5.08	V
	V _{OUT} T _{CASE} = -55°C to +105°C	3.21	3.30	3.38	4.87	5.00	5.13	V
Power ³		0	-	5	0	-	5	W
Current ³	I _{OUT}	0	-	1.52	0	-	1.0	A
Ripple Voltage	V _{OUT} Full Load, 20Hz to 10MHz	-	45	60	-	25	40	mV _{p-p}
Line Regulation	V _{OUT} V _{IN} = 15V to 50V	-	1	10	-	1	10	mV
Load Regulation	V _{OUT} No Load to Full Load	-	1	10	-	1	10	mV
EFFICIENCY		62	66	-	70	74	-	%
LOAD FAULT POWER DISSIPATION	Overload ⁴	-	-	3.7	-	-	3.3	W
	Short Circuit	-	-	3	-	-	3	W
CAPACITIVE LOAD ⁴		-	-	1000	-	-	1000	μF
SWITCHING FREQUENCY		425	500	550	425	500	550	kHz
ISOLATION	500 V _{DC}	100	-	-	100	-	-	MΩ
MTBF (MIL-HDBK-217F)	GM @ T _C = 55°C	-	468	-	-	468	-	kHrs
DYNAMIC								
Load Step Output Transient	V _{OUT} Half Load to Full Load	-	150	250	-	100	300	mV _{PK}
Load Step Recovery ²		-	400	600	-	300	500	μSec
Line Step Output Transient ⁴	V _{OUT} V _{IN} = 16V to 40V	-	200	400	-	200	500	mV _{PK}
Line Step Recovery ^{2, 4}		-	400	600	-	400	600	μSec
Turn On Delay	V _{OUT} V _{IN} = 0V to 28V	-	10	20	-	10	20	mSec
Turn On Overshoot		-	0	15	-	0	25	mV _{PK}

- Notes:
1. Dependent on output voltage.
 2. Time for output voltage to settle within 1% of its nominal value.
 3. Derate linearly to 0 at 115°C.
 4. Verified by initial electrical design verification. Post design verification, parameter shall be guaranteed to the limits specified.

SPECIFICATIONS (T_{CASE} = -55°C to +105°C, V_{IN} = +28V ± 5%, Full Load, Unless Otherwise Specified)

ABSOLUTE MAXIMUM RATINGS

Input Voltage (Continuous)	50 V _{DC}	Junction Temperature Rise to Case	+10°C
Input Voltage (Transient, 1 second)	80 Volts	Storage Temperature	-55°C to +125°C
Output Power ¹	5 Watts	Lead Solder Temperature (10 seconds)	300°C
Power Dissipation (Full Load, T _{CASE} = +105°C)	3 Watts	Weight (Maximum)	22 Grams

Parameter	Conditions	VPT5-2812S			VPT5-2815S			Units
		Min	Typ	Max	Min	Typ	Max	
STATIC								
INPUT Voltage ⁴	Continuous	15	28	50	15	28	50	V
	Transient, 1 sec	-	-	80	-	-	80	V
Current	Inhibited	-	4	6	-	4	6	mA
	No Load	-	40	60	-	40	60	mA
Ripple Current	Full Load, 20Hz to 10MHz	-	30	50	-	30	50	mA _{p-p}
Inhibit Pin Input ⁴		0	-	1.5	0	-	1.5	V
Inhibit Pin Open Circuit Voltage ⁴		9.0	11.0	13.0	9.0	11.0	13.0	V
UVLO Turn On		12.0	-	14.8	12.0	-	14.8	V
UVLO Turn Off ⁴		11.0	-	14.5	11.0	-	14.5	V
OUTPUT Voltage	V _{OUT} T _{CASE} = 25°C	11.82	12.0	12.18	14.77	15.0	15.23	V
	V _{OUT} T _{CASE} = -55°C to +105°C	11.70	12.0	12.30	14.62	15.0	15.38	V
Power ³		0	-	5	0	-	5	W
Current ³	I _{OUT}	0	-	0.42	0	-	0.33	A
Ripple Voltage	V _{OUT} Full Load, 20Hz to 10MHz	-	15	30	-	15	30	mV _{p-p}
Line Regulation	V _{OUT} V _{IN} = 15V to 50V	-	1	10	-	1	10	mV
Load Regulation	V _{OUT} No Load to Full Load	-	1	10	-	1	10	mV
EFFICIENCY		71	75	-	71	76	-	%
LOAD FAULT POWER DISSIPATION	Overload ⁴	-	-	3	-	-	3	W
	Short Circuit	-	-	3	-	-	3	W
CAPACITIVE LOAD ⁴		-	-	500	-	-	500	μF
SWITCHING FREQUENCY		425	500	550	425	500	550	kHz
ISOLATION	500 V _{DC}	100	-	-	100	-	-	MΩ
MTBF (MIL-HDBK-217F)	GM @ T _C = 55°C	-	468	-	-	468	-	kHrs
DYNAMIC								
Load Step Output Transient	V _{OUT} Half Load to Full Load	-	200	400	-	200	400	mV _{PK}
Load Step Recovery ²		-	200	400	-	200	400	μSec
Line Step Output Transient ⁴	V _{OUT} V _{IN} = 16V to 40V	-	450	700	-	450	700	mV _{PK}
Line Step Recovery ^{2, 4}		-	300	500	-	300	500	μSec
Turn On Delay	V _{OUT} V _{IN} = 0V to 28V	-	10	20	-	10	20	mSec
Turn On Overshoot		-	0	50	-	0	50	mV _{PK}

- Notes:
1. Dependent on output voltage.
 2. Time for output voltage to settle within 1% of its nominal value.
 3. Derate linearly to 0 at 115°C.
 4. Verified by initial electrical design verification. Post design verification, parameter shall be guaranteed to the limits specified.

BLOCK DIAGRAM

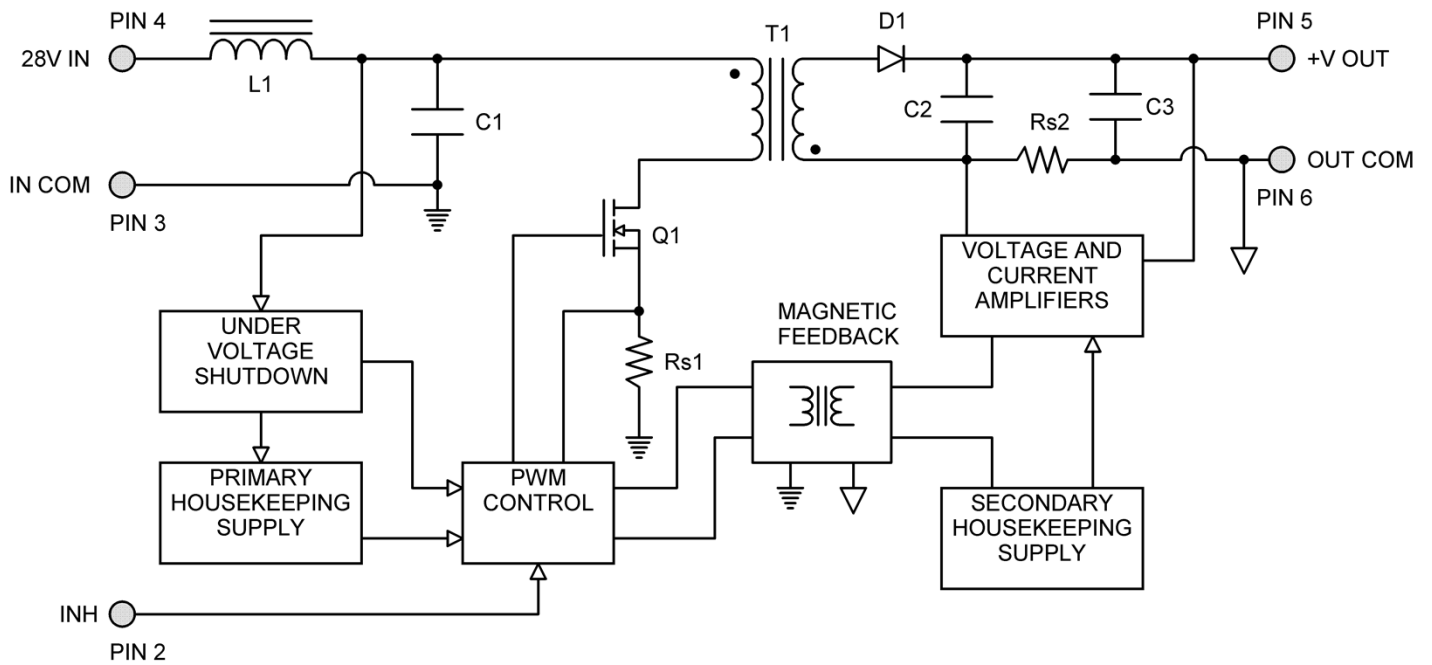

Figure 2

CONNECTION DIAGRAM

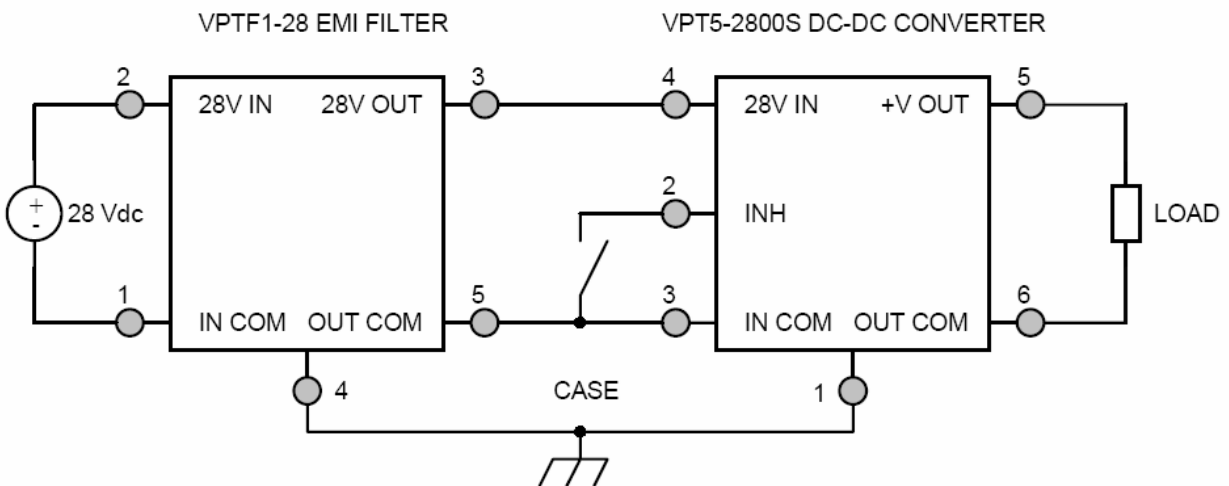

Figure 3
(Shown with optional EMI filter)

INHIBIT DRIVE CONNECTION DIAGRAMS

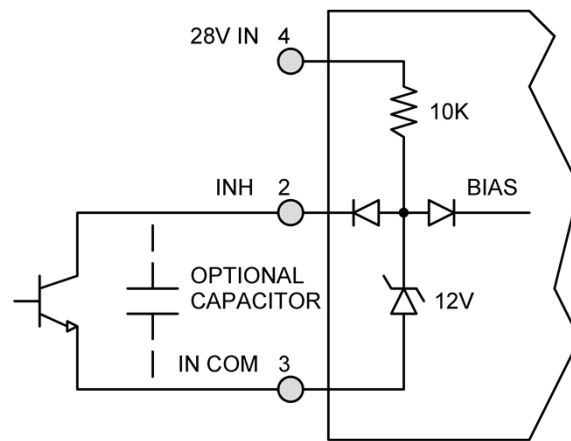

Figure 4 – Inhibit Circuit

(Shown with optional capacitor for turn-on delay)

EFFICIENCY PERFORMANCE CURVES ($T_{CASE} = 25^{\circ}C$, Full Load, Unless Otherwise Specified)

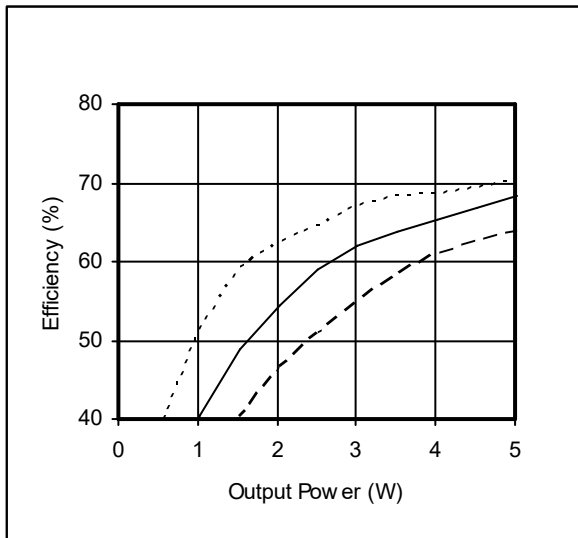

Figure 5 – VPT5-283R3S
Efficiency (%) vs. Output Power (W)

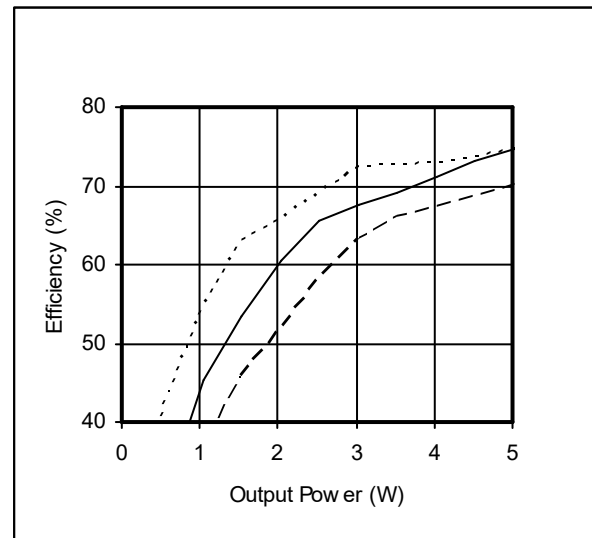

Figure 6 – VPT5-2805S
Efficiency (%) vs. Output Power (W)

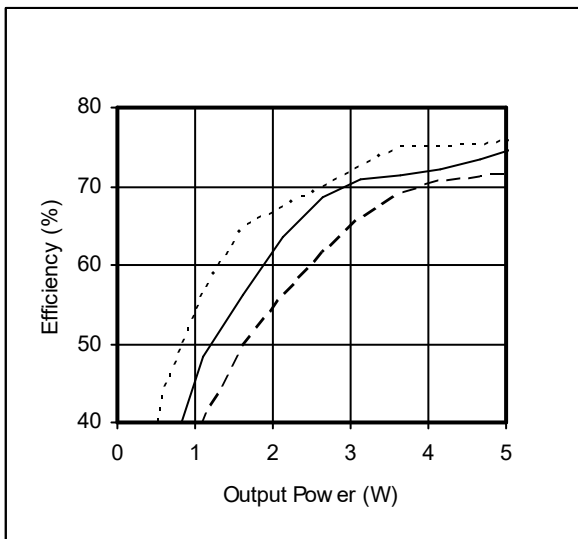

Figure 7 – VPT5-2812S
Efficiency (%) vs. Output Power (W)

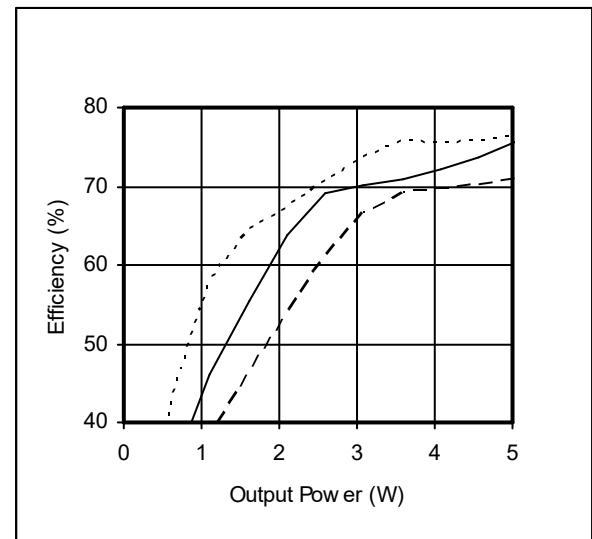

Figure 8 – VPT5-2815S
Efficiency (%) vs. Output Power (W)

EMI PERFORMANCE CURVES

($T_{CASE} = 25^{\circ}C$, $V_{IN} = +28V \pm 5\%$, Full Load, Unless Otherwise Specified)

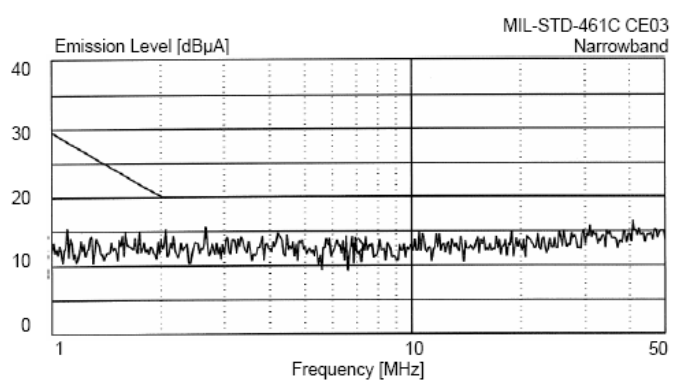
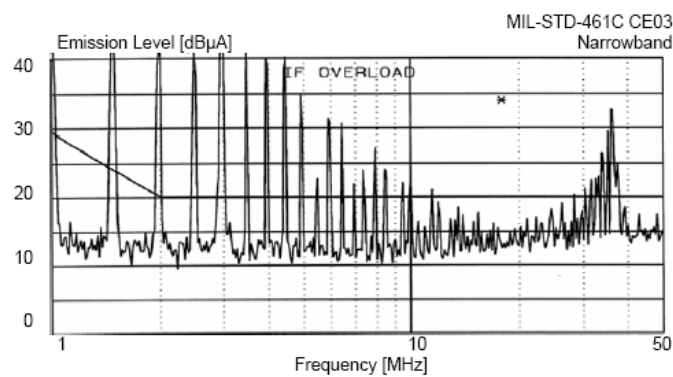
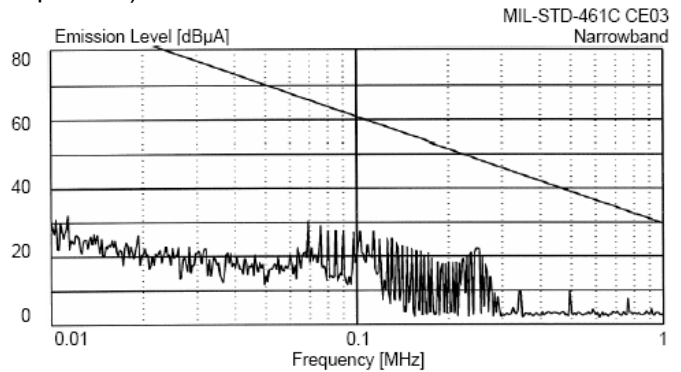
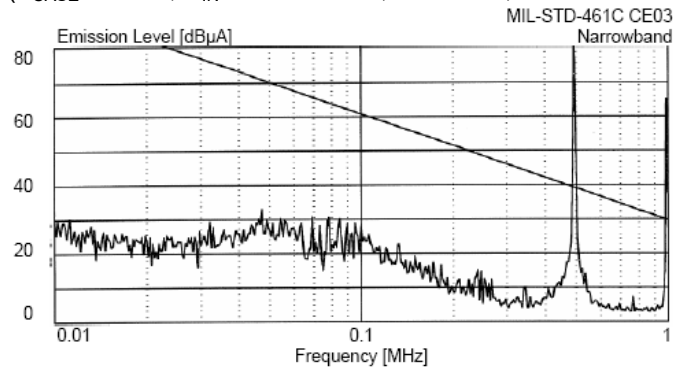

Figure 9 –VPT5-2800S without EMI Filter

Figure 10 – VPT5-2800S with VPTF Series EMI Filter

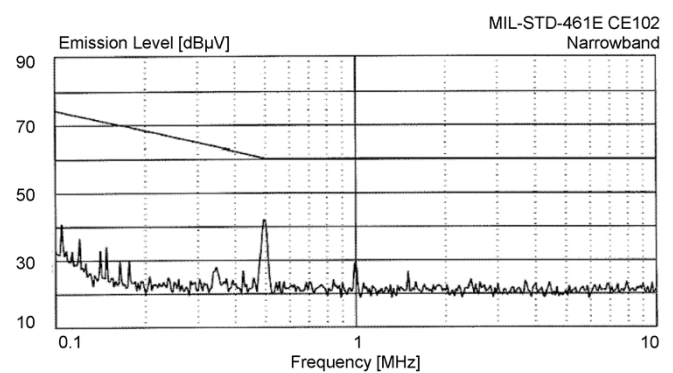
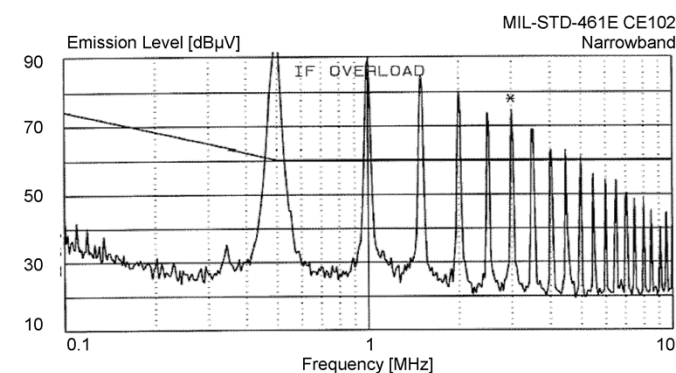
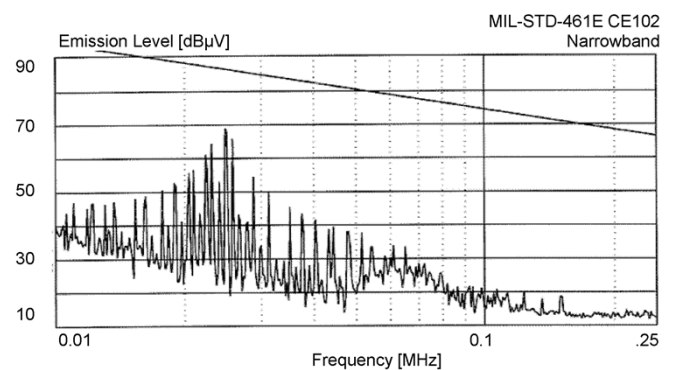
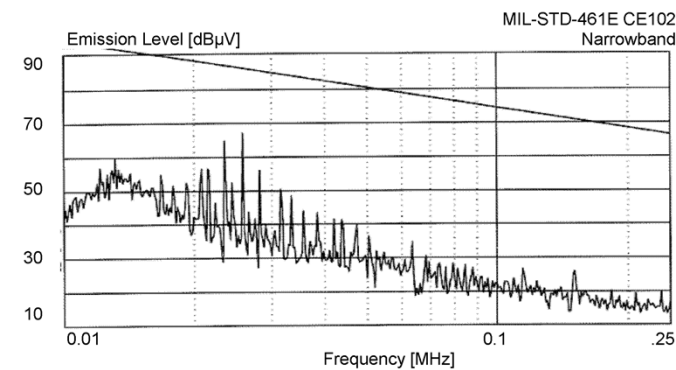

Figure 11 –VPT5-2800S without EMI Filter

Figure 12 –VPT5-2800S with VPTF Series EMI Filter

STANDARD METAL PACKAGE

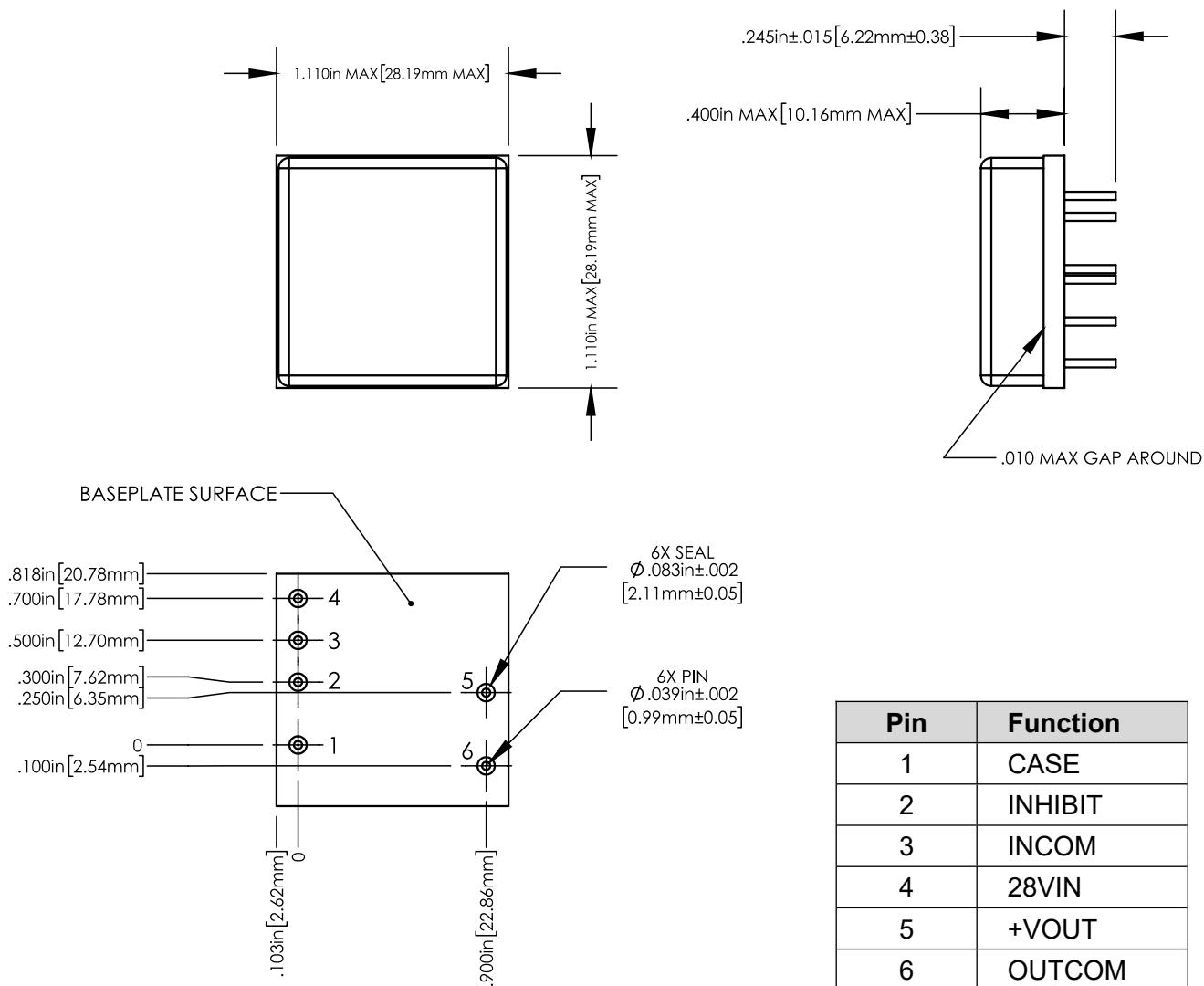

Figure 13 – Package and Pinout
(Dimensional Limits are ± 0.005 " Unless Otherwise Stated)

Package Notes

1. Case temperature is measured on the center of the baseplate surface.
2. Materials: Baseplate – aluminum, conductive conversion coating.
Cover – nickel plated.
Pins - copper, gold over nickel plating.
3. This Package is not hermetic.
4. For applications requiring exposure to liquid cleaning, please contact VPT.

PACKAGE PIN DESCRIPTION

Pin	Function	Description
1	CASE	Case Connection
2	INHIBIT	This is an open collector input. Logic Low = Disabled Output. Connect the inhibit pin to input common to disable the output. Unconnected, open collector or open drain = Enabled Output.
3	INCOM	Input Return Connection
4	28VIN	Positive Input Voltage Connection
5	+VOUT	Positive Output Voltage Connection
6	OUTCOM	Output Return Connection

100% ENVIRONMENTAL SCREENING

Screening	Condition
Internal Visual	IPC-A-610, Class 3
Temperature Cycling	MIL-STD-883, Method 1010, Condition B, -55°C to +125°C, 10 Cycles
Burn-In	96 hours at +105°C
Final Electrical	100% at 25°C
External Visual	Internal Procedure



ORDERING INFORMATION

VPT5-	28	05	S
1	2	3	4

(1) Product Series	(2) Nominal Input Voltage		(3) Output Voltage		(4) Number of Outputs	
VPT5-	28	28 Volts	3R3 05 12 15	3.3 Volts 5 Volts 12 Volts 15 Volts	S	Single

CONTACT INFORMATION

To request a quotation or place orders please contact your sales representative or the VPT Inc. Sales Department at:

Phone: (425) 353-3010
Fax: (425) 353-4030
E-mail: vptsales@vptpower.com

All information contained in this datasheet is believed to be accurate, however, no responsibility is assumed for possible errors or omissions. The products or specifications contained herein are subject to change without notice. VPT, its logo and tagline are registered trademarks in the U.S. Patent and Trademark Office.