

# VPTHVM-270 Series

## HIGH RELIABILITY COTS REGULATED BUS CONVERTER MODULE

### DESCRIPTION

The VPTHVM-270 is an isolated, regulated Bus Converter module which allows VPT's DV and VPT Series 28V input DC-DC converters to operate from a nominal 270V DC input. A wide input voltage range accommodates MIL-STD-704 input power requirements for avionics, mobile, ground, and other applications. A regulated high efficiency design reduces input power requirements and eases thermal management. A proven design heritage, no optoisolators and a rugged all metal package ensure long term reliability.

The VPTHVM-270 is intended for harsh environments including severe vibration, shock and temperature cycling. Testing is to JESD22, MIL-STD-810, and MIL-STD-883.

These converters are designed and manufactured in a facility certified to ISO9001, J-STD-001 and IPC-A-610.

This product may incorporate one or more of the following U.S. patents:

5,784,266  
5,790,389  
5,963,438  
5,999,433  
6,005,780  
6,084,792  
6,118,673

### FEATURES

- High Reliability at Low Cost
- Up to 200 Watts of Output Power
- High Efficiency, Up to 91%
- Wide Input Voltage Range: 160 to 400 Volts per MIL-STD-704
- High Input Transient Voltage: 500V for 1 Second
- High Isolation, 2250V
- Parallel Up to 5 Units with Current Sharing
- Input Undervoltage Lockout
- Fixed Frequency
- Frequency Synchronization
- Output Soft Start
- Current Limit Protection
- Short Circuit Protection
- Magnetic Feedback, No Optoisolators
- Wide Temperature Range: -55°C to 100°C Baseplate with No Derating
- Internally Conformal Coated
- Standard Six Sided Non-Hermetic Rugged Metal Package



**Figure 1 – VPTHVM-270 Regulated Bus Converter**  
(Not to Scale)

## SPECIFICATIONS (T<sub>CASE</sub> = -55°C to +100°C, V<sub>IN</sub> = +270V ± 5%, Full Load, Unless Otherwise Specified)

### ABSOLUTE MAXIMUM RATINGS

Input Voltage (Continuous)	400 V <sub>DC</sub>	Junction Temperature Rise to Case	+15°C
Input Voltage (Transient, 1 second)	500 Volts	Storage Temperature	-55°C to +125°C
Output Power	200 Watts	Lead Solder Temperature (10 seconds)	300°C
Power Dissipation (Full Load, T <sub>CASE</sub> = +100°C)	25 Watts	Weight	88g

Parameter	Conditions	VPTHVM-270			Units
		Min	Typ	Max	
<b>STATIC</b>					
INPUT Voltage	Continuous	180	-	350	V
	Continuous, P <sub>out</sub> ≤ 150W	160	-	400	V
	Transient, 1 sec <sup>3</sup>	160	-	500	V
Current	Inhibited	-	2	4	mA
	No Load	-	3	6	mA
Ripple Current	20Hz to 10MHz	-	50	250	mA <sub>p-p</sub>
Inhibit Pin Input <sup>3</sup>		0	-	1.5	V
Inhibit Pin Open Circuit Voltage <sup>3</sup>		3	4.5	6	
UVLO Turn On		-	156	159	V
UVLO Turn Off <sup>3</sup>		145	150	-	V
OUTPUT Voltage	V <sub>OUT</sub> Vin = 270V	26	27	30	V
	V <sub>OUT</sub> Vin = 160V to 500V	16	27	30	V
Power <sup>1</sup>		0	-	200	W
Ripple Voltage	V <sub>OUT</sub> 20Hz to 10MHz	-	100	250	mV <sub>p-p</sub>
Load Regulation	V <sub>OUT</sub> No Load to Full Load	-	100	300	mV
EFFICIENCY		87	91	-	%
CAPACITIVE LOAD <sup>3</sup>		-	-	250	μF
Load Fault Power Dissipation <sup>3</sup>	Overload	-	27	35	W
	Short Circuit	-	19	35	W
SWITCHING FREQUENCY		350	450	550	kHz
SYNC FREQUENCY RANGE	V <sub>H</sub> -V <sub>L</sub> =5V, Duty=50%	550	-	650	kHz
ISOLATION	2250 V <sub>DC</sub>	100	-	-	MΩ
MTBF (MIL-HDBK-217F)	GM @ T <sub>C</sub> = 55°C	-	429	-	kHrs
<b>DYNAMIC</b>					
Load Step Output Transient	V <sub>OUT</sub> Half Load to Full Load	-	1	3	V <sub>PK</sub>
Load Step Recovery <sup>2</sup>		-	100	300	μSec
Turn On Delay	V <sub>IN</sub> = 0V to 270V	-	10	20	mSec
Turn On Overshoot		-	0	150	mV <sub>PK</sub>

- Notes:
1. Derate linearly to 0 at 110°C
  2. Time for output voltage to settle within 1% of its nominal value.
  3. Verified by qualification testing

## BLOCK DIAGRAM

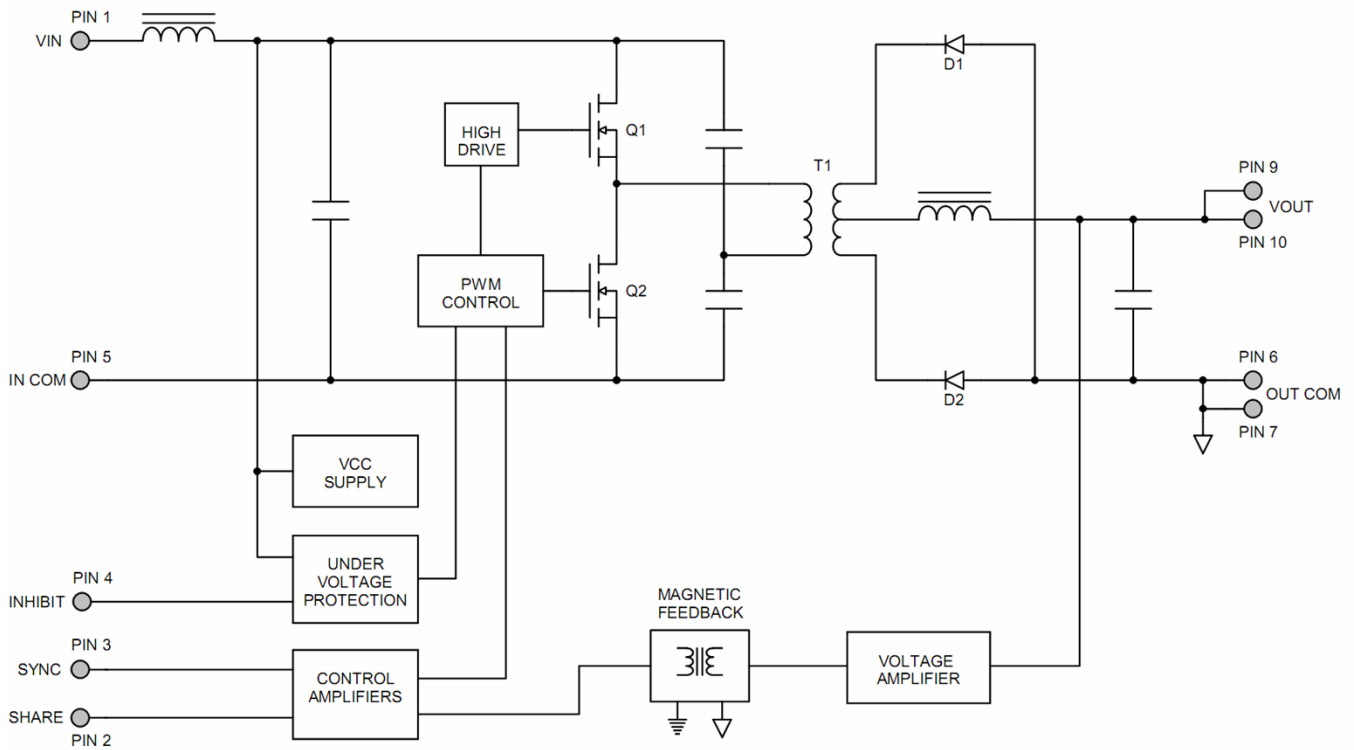


Figure 2

## CONNECTION DIAGRAM

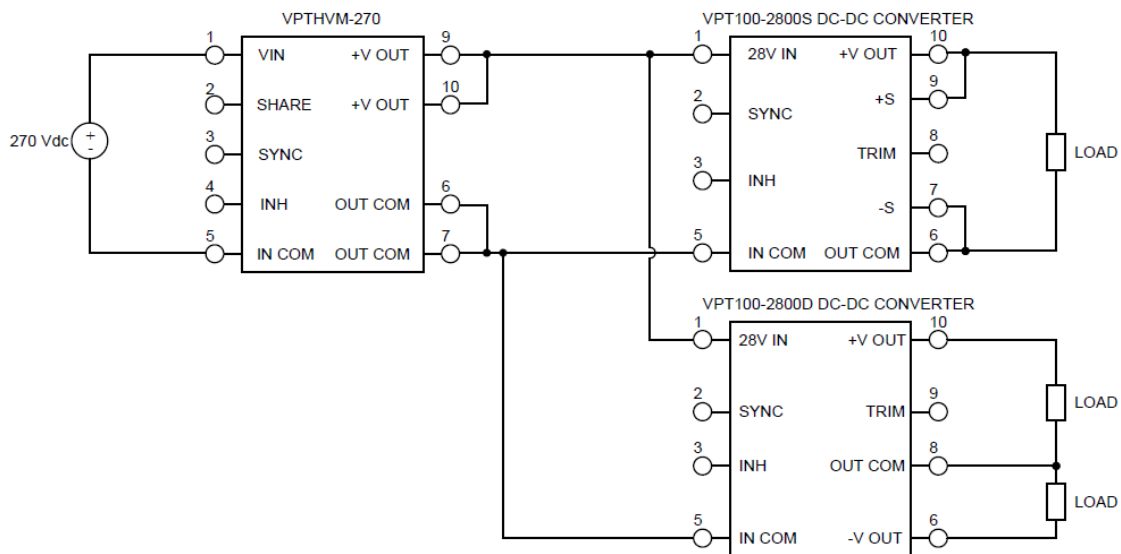


Figure 3

## CONNECTION DIAGRAM

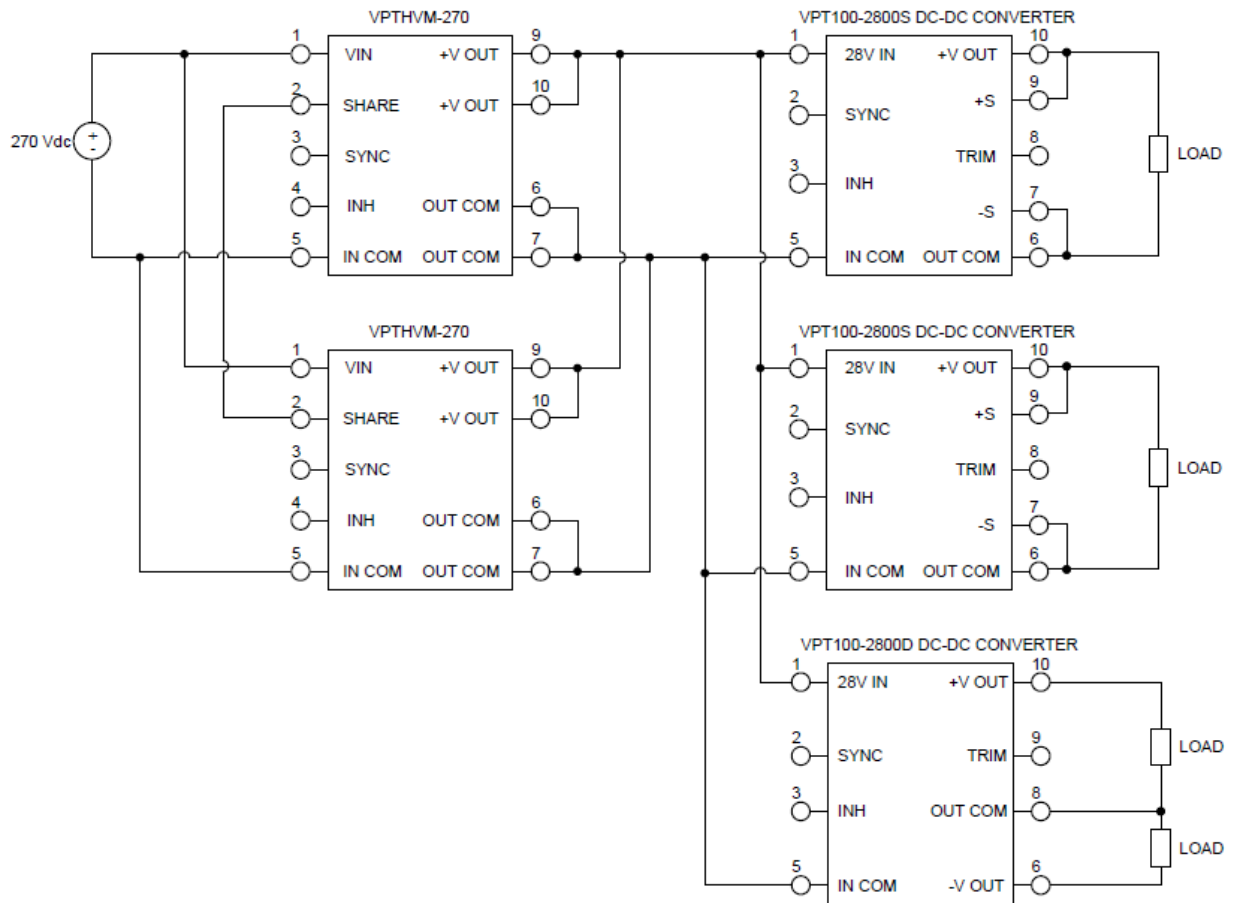


Figure 4

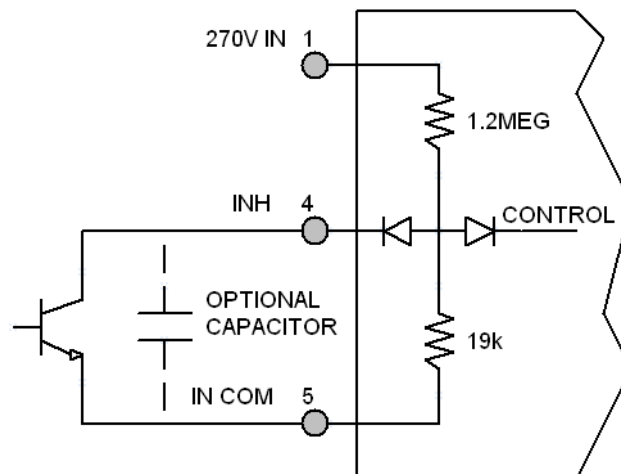
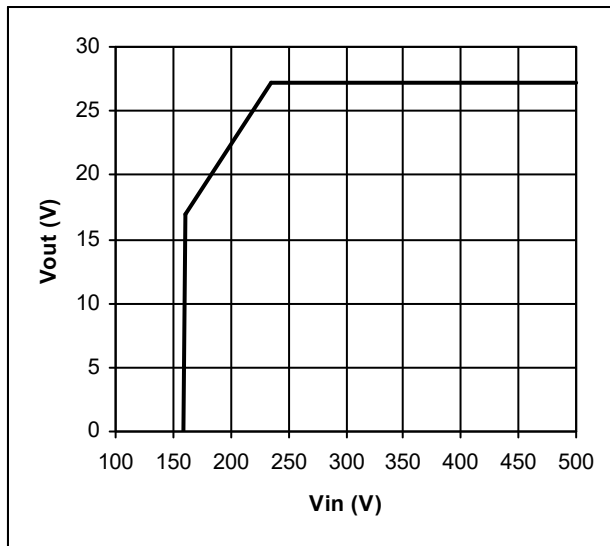
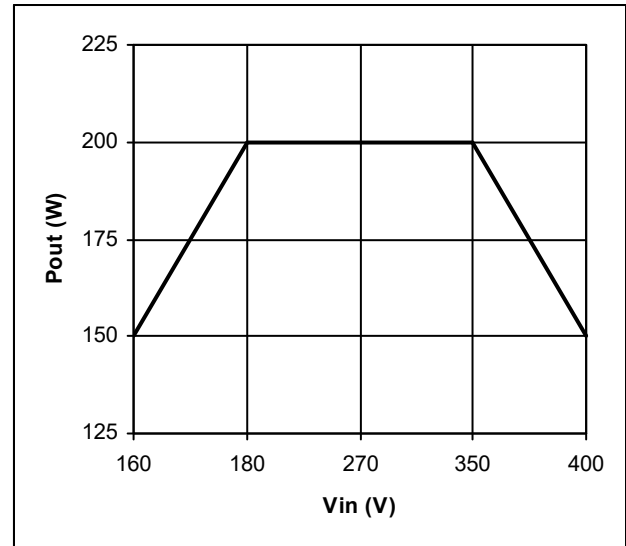


Figure 5 - Inhibit Circuit  
(Shown with optional capacitor for turn-on delay)

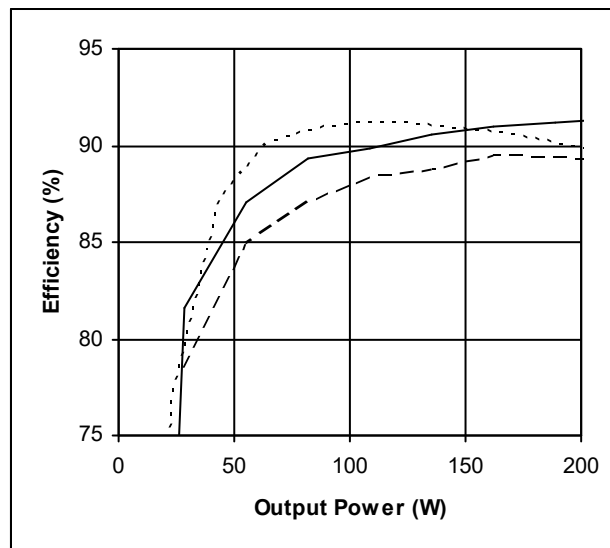
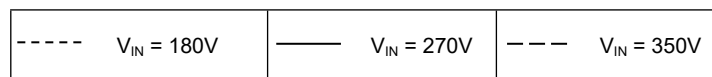
## PERFORMANCE CURVES (T<sub>CASE</sub> = 25°C, Full Load, Unless Otherwise Specified)



**Figure 6** – Output Voltage vs Input Voltage

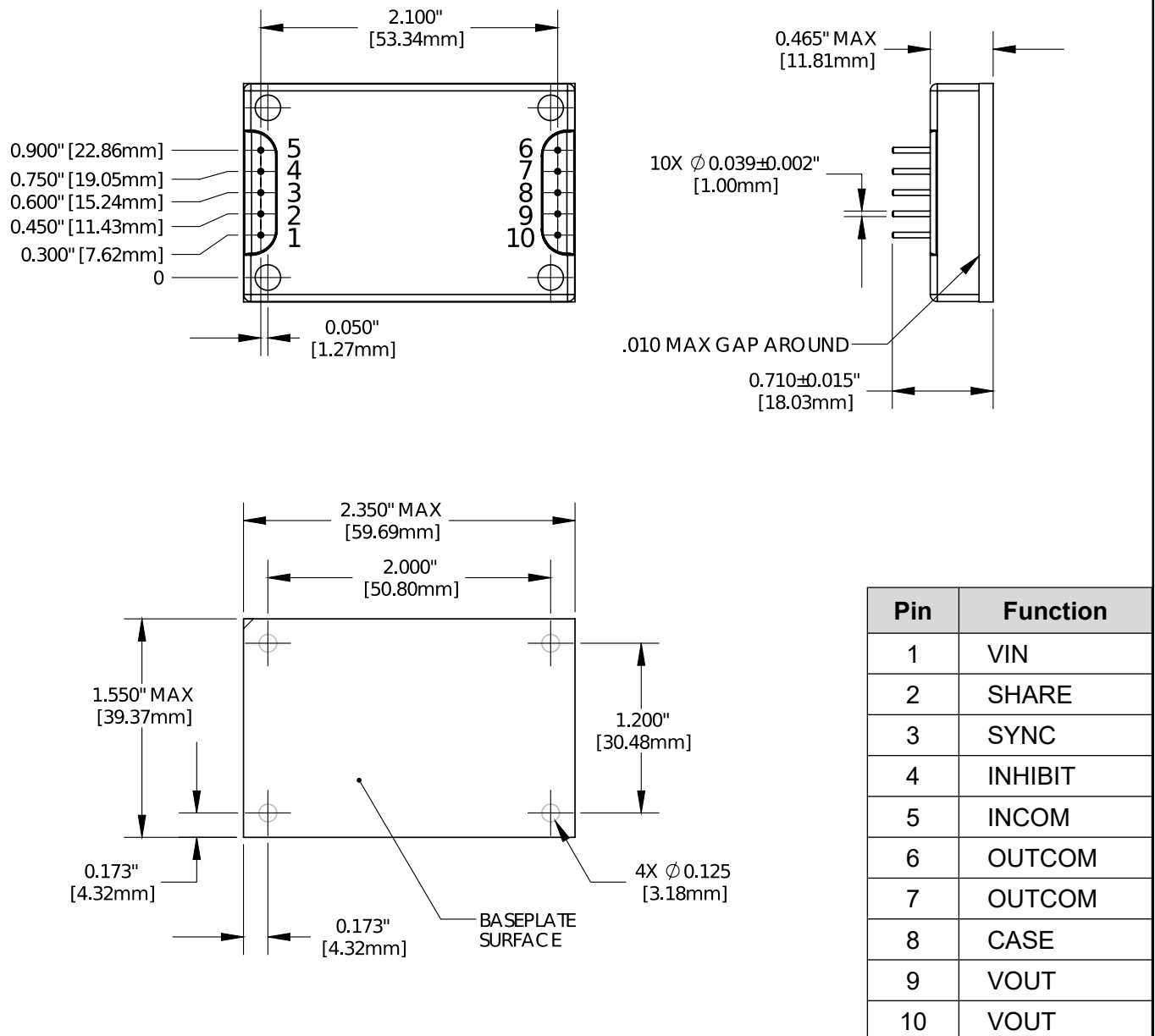


**Figure 7** – Output Power vs Input Voltage



**Figure 8** – Efficiency (%) vs. Output Power (W)

## STANDARD METAL PACKAGE



**Figure 9 – Package and Pinout**  
(Dimensional Limits are  $\pm 0.005$ " Unless Otherwise Stated)

### Package Notes

- Case temperature is measured on the center of the baseplate surface.
- Materials: Baseplate – aluminum, conductive conversion coating.  
Cover – nickel plated.  
Pins - copper, gold over nickel plating.
- Mounting holes are not threaded. Recommended fastener is 4-40.
- This Package is not hermetic.

## PACKAGE PIN DESCRIPTION

Pin	Function	Description
1	VIN	Positive Input Voltage Connection
2	SHARE	Current Share connection for parallel operation. Leave open if not used. Input referenced.
3	SYNC	Frequency Synchronization Input. Apply a TTL squarewave, 5Vpp, 20 - 80% duty cycle, internally capacitively coupled. Leave open if not used. Input referenced.
4	INHIBIT	This is an open collector input. Logic Low = Disabled Output. Connect the inhibit pin to input common to disable the output. Unconnected, open collector or open drain = Enabled Output. Input referenced.
5	INCOM	Input Return Connection
6	OUTCOM	Output Return Connection
7	OUTCOM	Output Return Connection
8	CASE	Case Connection
9	VOUT	Positive Output Voltage Connection
10	VOUT	Positive Output Voltage Connection

## 100% ENVIRONMENTAL SCREENING

Screening	Condition
Internal Visual	IPC-A-610, Class 3
Stabilization Bake	MIL-STD-883, Method 1008, Condition B, 125°C, 24 hours
Temperature Cycling	MIL-STD-883, Method 1010, Condition B, -55°C to +125°C, 10 Cycles
Burn-In	96 hours at +100°C
Final Electrical	100% at 25°C
External Visual	Internal Procedure



## ORDERING INFORMATION

VPTHVM-	270
1	2

(1)	(2)	
Product Series	Nominal Input Voltage	
VPTHVM-	270	160 – 400 Volts

## CONTACT INFORMATION

To request a quotation or place orders please contact your sales representative or the VPT Inc. Sales Department at:

**Phone:** (425) 353-3010  
**Fax:** (425) 353-4030  
**E-mail:** [vptsales@vptpower.com](mailto:vptsales@vptpower.com)

All information contained in this datasheet is believed to be accurate, however, no responsibility is assumed for possible errors or omissions. The products or specifications contained herein are subject to change without notice. VPT, its logo and tagline are registered trademarks in the U.S. Patent and Trademark Office.