



Power Your Critical Mission Today

VPTc10-28 Series

HIGH RELIABILITY COTS EMI FILTER / TRANSIENT PROTECTION MODULE

DESCRIPTION

The VPTc10-28 input module is a combined EMI filter and voltage transient protection module with built-in reverse polarity protection. Compatible with VPT's DV and VPT series isolated DC-DC converters, the VPTc10-28 provides compliance for both ISO 7637-2 and DEF STAN 61-5 Part 6 Issue 6 input power requirements for vehicle systems. The VPTc10-28 also provides compliance for DEF STAN 61-5 Part 6 Issue 5, MIL-STD-1275, and MIL-STD-704, and reduces the reflected noise of the DC-DC converters to meet conducted emissions and conducted susceptibility requirements of DEF STAN 59-411 Part 3 Issue 1 and MIL-STD-461. A proven design heritage, no optoisolators and a rugged all metal or optional epoxy encapsulated package ensure long term reliability.

The VPTc10-28 is intended for harsh environments including severe vibration, shock and temperature cycling. Testing is to JESD22, MIL-STD-810, and MIL-STD-883.

These converters are designed and manufactured in a facility certified to ISO9001, J-STD-001 and IPC-A-610.

This product may incorporate one or more of the following U.S. patents:

- 5,784,266
- 5,790,389
- 5,963,438
- 5,999,433
- 6,005,780
- 6,084,792
- 6,118,673

FEATURES

- High Reliability at Low Cost
- Up to 10 Amps of Output Current
- Up to 150W of Output Power
- Wide Input Voltage Range
- Transient Operation up to 202 Volts per the Load Dump Requirement of ISO 7637-2 and DEF STAN 61-5 Part 6 Issue 6
- Transient Operation up to 100 Volts per DEF STAN 61-5 Part 6 Issue 5 and MIL-STD-1275
- Transient Operation up to 80 Volts per MIL-STD-704
- 45 dB Minimum Attenuation at 500 kHz
- Provides Inrush Current Limiting
- True Reverse Polarity Protection
- Wide Temperature Range, -55°C to 105°C
- Internally Conformal Coated
- Standard Six Sided Non-Hermetic Rugged Metal Package
- Optional Six Sided Rugged Epoxy Encapsulated Package with Integral Metalized EMI shield that is fully compatible with aqueous cleaning processes
- Meets Conducted Emissions Requirements of DEF STAN 59-411 Part 3 Issue 1 and MIL-STD-461C-G When Used With VPT Series DC-DC Converters
- Meets Conducted Susceptibility Requirements of DEF STAN 59-411 Part 3 Issue 1 for Land Applications, MIL-STD-461C, CS01 and CS02, and MIL-STD-461D-G when used with VPT Series DC-DC Converters



Figure 1 – VPTc10-28 Input Module Standard Metal Package



Figure 2 – VPTc10-28W Input Module Optional Epoxy Encapsulated Package

(Not To Scale)

Sales Information:
Phone: (425) 353-3010
Fax: (425) 353-4030
E-mail: vp.sales@vptpower.com

SPECIFICATIONS (T_{CASE} = -55°C to +105°C, V_{IN} = +28V ± 5%, Full Load, Unless Otherwise Specified)

ABSOLUTE MAXIMUM RATINGS

Input Voltage (Continuous)	40 V _{DC}	Junction Temperature Rise to Case	+15°C
Input Voltage (Transient)	202 Volts	Storage Temperature	-55°C to +125°C
Output Current	10 Amps	Lead Solder Temperature (10 seconds)	300°C
Power Dissipation (Full Load, T _{CASE} = +105°C)	12 Watts	Weight (Maximum)	66 Grams

Parameter	Conditions	VPTc10-28			Units	
		Min	Typ	Max		
STATIC						
INPUT Voltage	Continuous		-40	28	40	V
	Transient	1 sec ²	-	-	50	V
	Transient	100 ms, 500 mΩ per MIL-STD-1275	-	-	100	V
	Transient	350ms, 1Ω per ISO 7637-2 Load Dump ²	-	-	202	V
	Transient	1μs, 50Ω or 70 μs, 15 mJ	-250	-	250	V
	Transient	10 μs, 50Ω	-	-	600	V
Current	Inhibited	-	-	10	mA	
Inrush Current ²	V _{in} = 0 to 28V, Full Load	-	5	10	A	
Inhibit Pin Input ²		0	-	1.5	V	
Inhibit Pin Open Circuit Voltage ²		10	12	16	V	
UVLO Turn On		-	9	11	V	
UVLO Turn Off ²		5	8	-	V	
OUTPUT Voltage	Continuous	0	-	40	V	
	Transient	0	-	50	V	
Current ¹		0	-	10	A	
Power ¹		0	-	150	W	
DC RESISTANCE		-	50	120	mΩ	
NOISE REJECTION	f = 500 kHz	45	65	-	dB	
CAPACITANCE	Any Pin to Case	57	-	135	nF	
CASE ISOLATION	1500 V _{DC}	100	-	-	MΩ	
MTBF (MIL-HDBK-217F)	GM @ T _C = 55°C	-	501	-	kHrs	
DYNAMIC						
Turn On Delay	V _{IN} = 0V to 28V	-	4	10	mSec	

- Notes:
1. Derate linearly to 0 at 115°C.
 2. Verified by initial electrical design verification. Post design verification, parameter shall be guaranteed to the limits specified.

BLOCK DIAGRAM

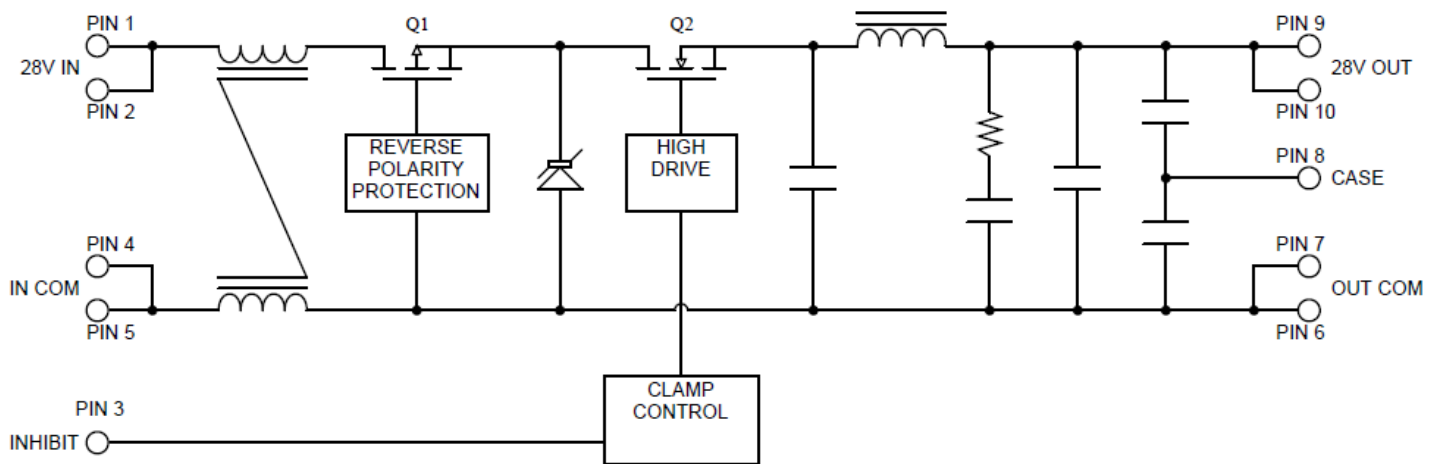

Figure 3

CONNECTION DIAGRAM

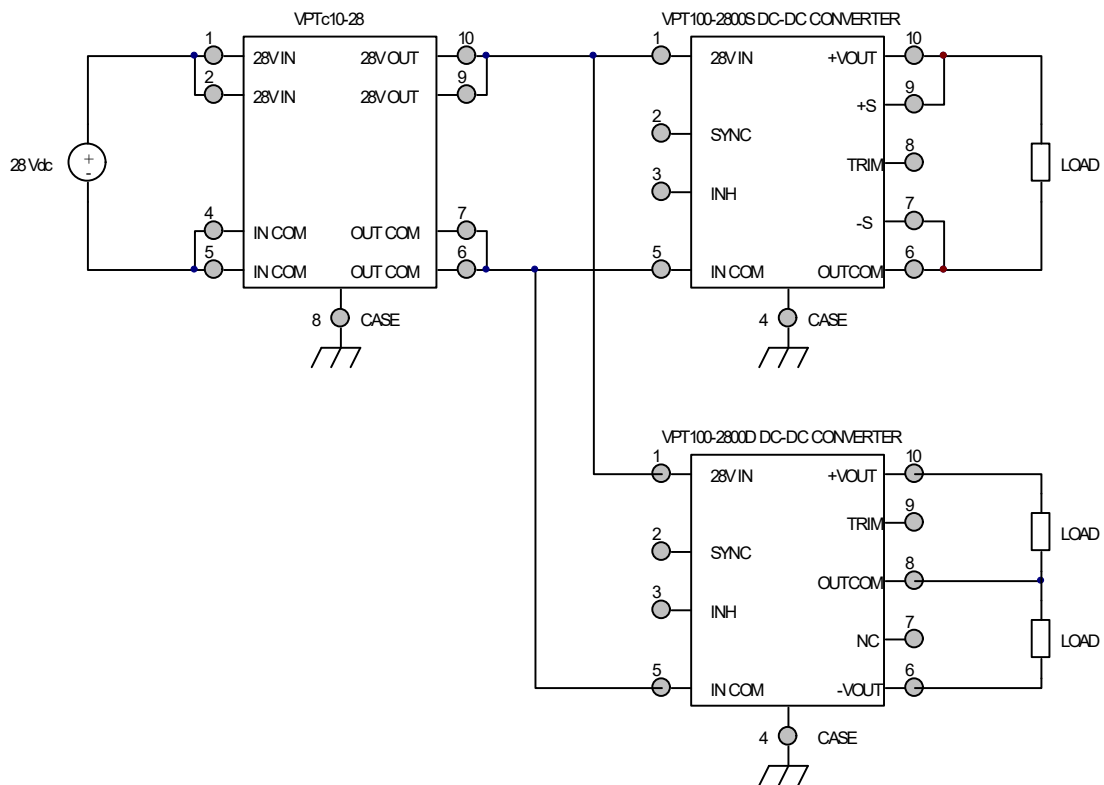

Figure 4

(Shown with Two VPT100-2800S&D Series DC-DC Converters)

PERFORMANCE CURVES

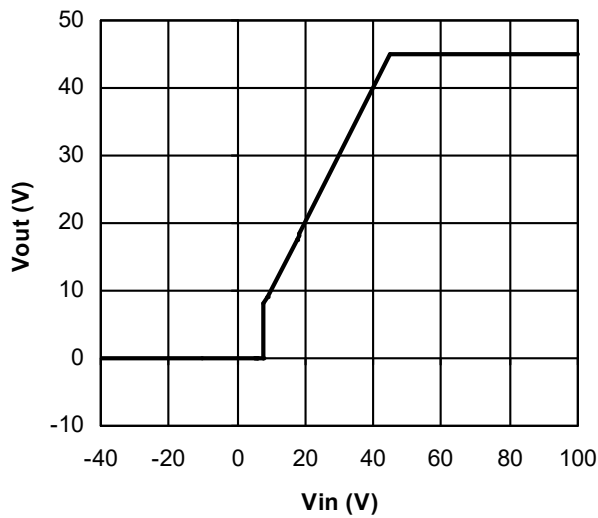

Figure 5 – Output Voltage vs Input Voltage

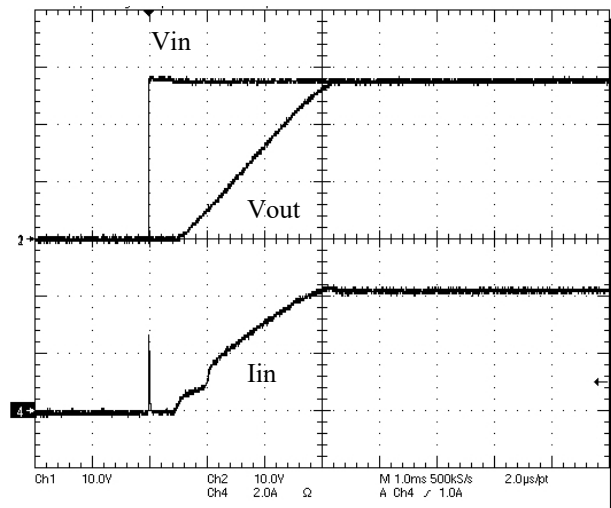

Figure 6 – Vout, Iin (Inrush current) during turn-on

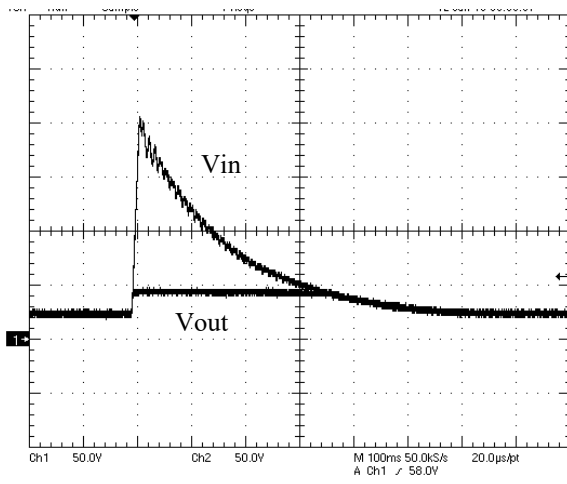

Figure 7 – Vin, Vout during 202V, 350ms Transient

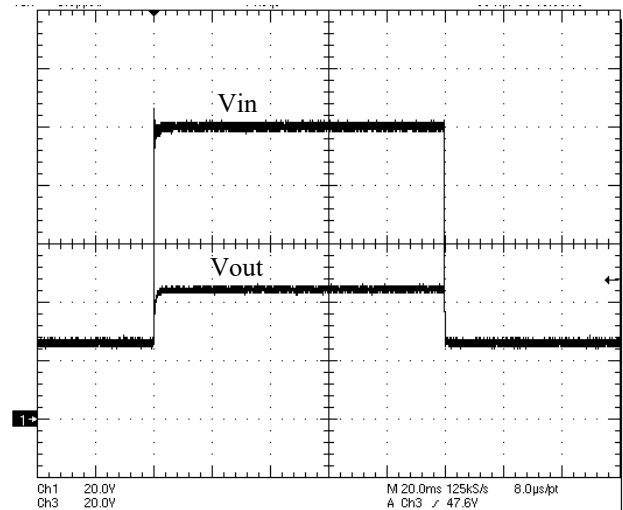

Figure 8 – Vin, Vout during 100V, 100ms Transient

EMI PERFORMANCE CURVES

($T_{CASE} = 25^{\circ}C$, $V_{IN} = +28V \pm 5\%$, Full Load, Unless Otherwise Specified)

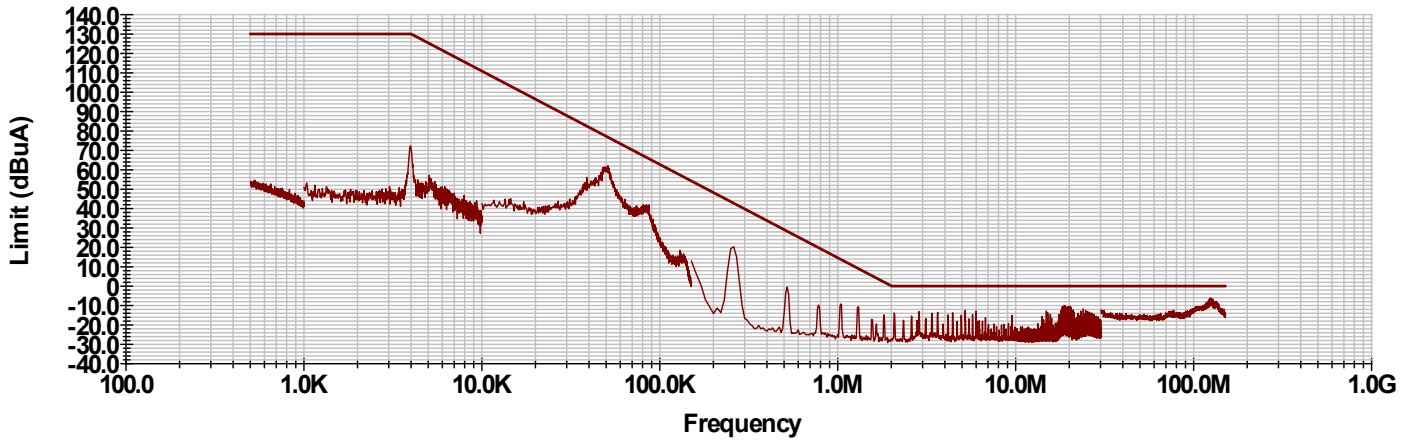

Figure 9 – DEF STAN 59-411 Part 3 Issue 1, DCE01.B for Land Service Use, Class A
(Two VPT100-2800S With VPTc10-28 Input Module at 150W)

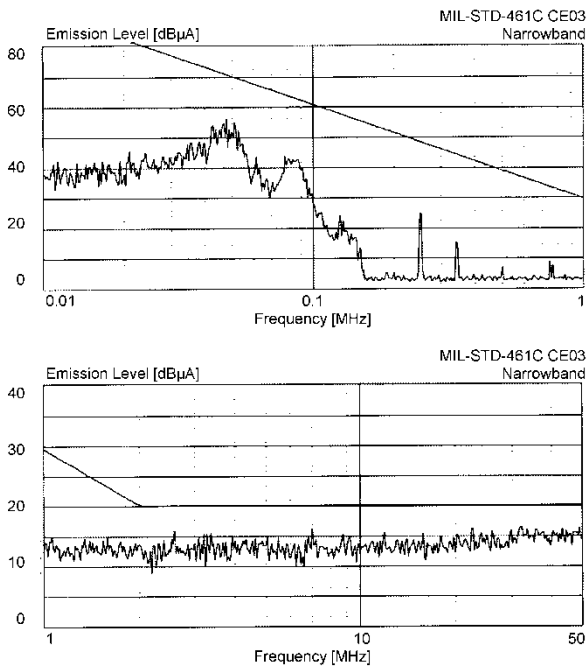

Figure 10 – MIL-STD-461C
Two VPT100-2800S With VPTc10-28 Input Module

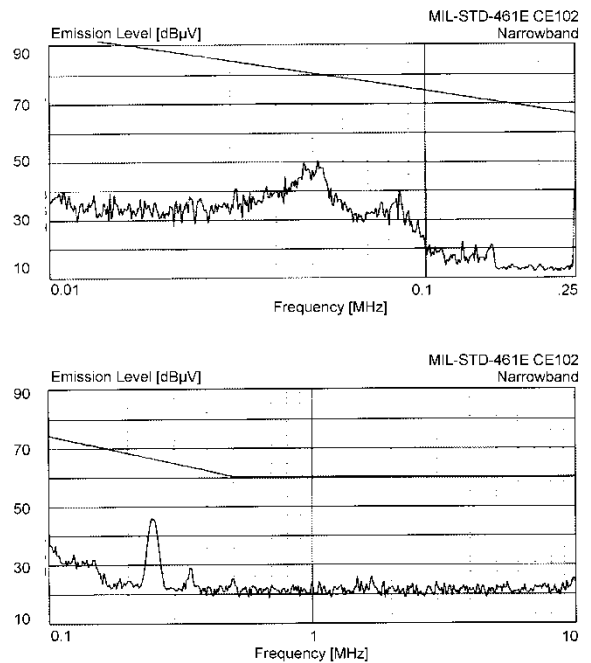
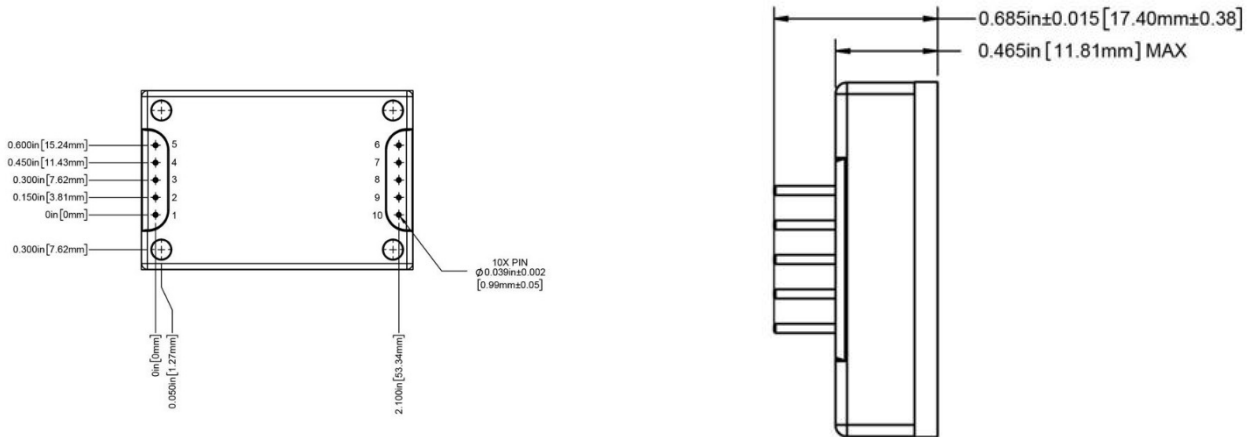

Figure 11 – MIL-STD-461D/E/F/G
Two VPT100-2800S With VPTc10-28 Input Module

STANDARD METAL PACKAGE



TOP VIEW

SIDE VIEW

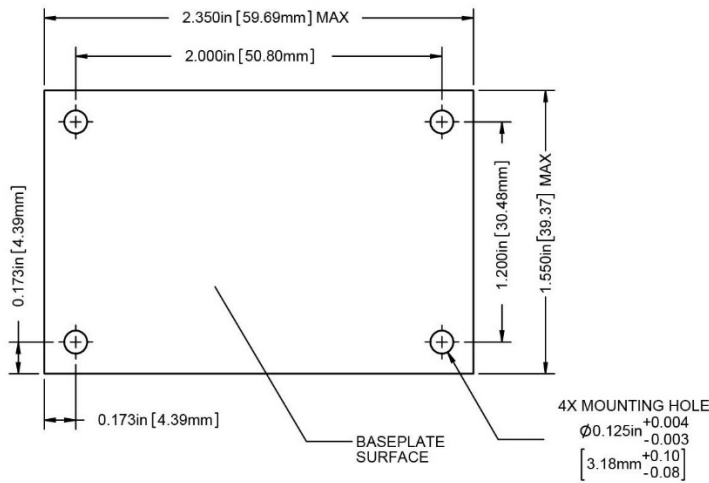

BOTTOM VIEW

Pin	Function
1	VIN
2	VIN
3	INHIBIT
4	INCOM
5	INCOM
6	OUTCOM
7	OUTCOM
8	CASE
9	VOUT
10	VOUT

Figure 12 – Package and Pinout
(Dimensional Limits are ± 0.005 " Unless Otherwise Stated)

Package Notes

- Case temperature is measured on the center of the baseplate surface.
- Materials: Baseplate – aluminum, conductive conversion coating.
Cover – brass, nickel plated.
Pins - copper, gold over nickel plating.
- Mounting holes are not threaded. Recommended fastener is 4-40.
- This Package is not hermetic. VPT offers a wide range of hermetic products. Please contact VPT for details if hermetic products are required.

OPTIONAL EPOXY ENCAPSULATED PACKAGE

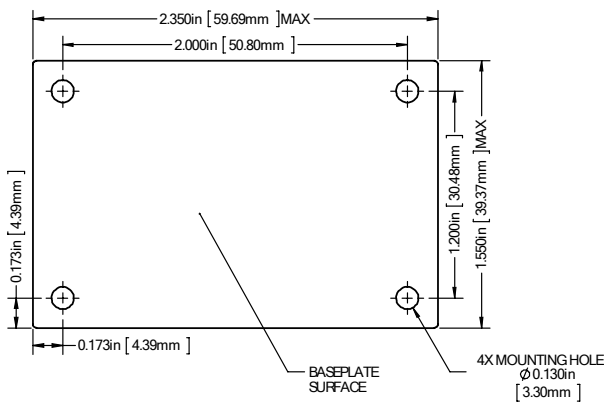
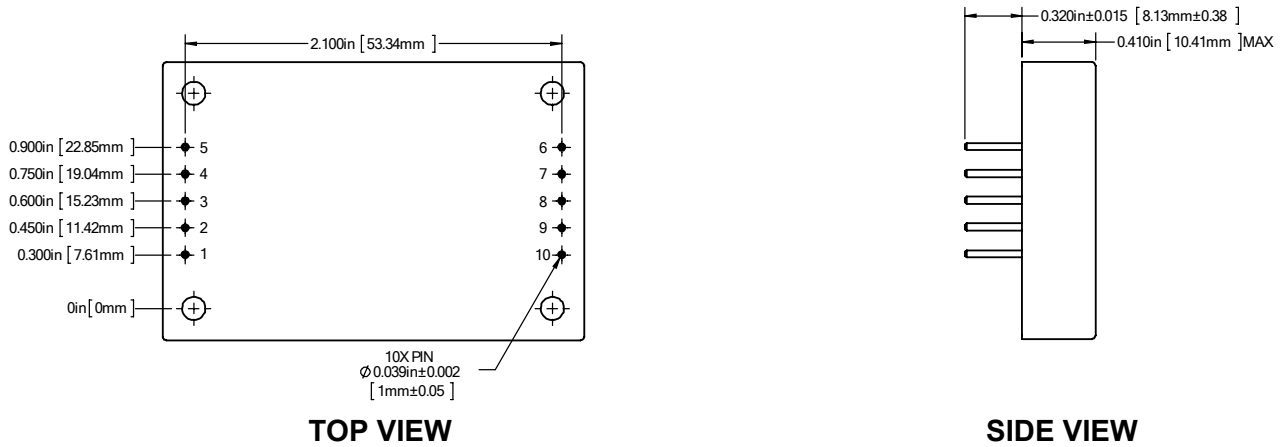

Pin	Function
1	VIN
2	VIN
3	INHIBIT
4	INCOM
5	INCOM
6	OUTCOM
7	OUTCOM
8	CASE
9	VOUT
10	VOUT

BOTTOM VIEW

Figure 13 – Package and Pinout
(Dimensional Limits are ±0.010" Unless Otherwise Stated)

Package Notes

1. Case temperature is measured on the center of the baseplate surface.
2. Materials: Body - epoxy with integral metalized EMI shield.
Pins - copper, gold over nickel plating.
3. Mounting holes are not threaded. Recommended fastener is 4-40.
4. This package is highly resistant to chemical, solvent and salt environments and is fully compatible with high volume manufacturing processes including wave solder, cleaning solvents, high pressure sprays and aqueous wash processes.

PACKAGE PIN DESCRIPTION

Pin	Function	Description
1	VIN	Positive Input Voltage Connection
2	VIN	Positive Input Voltage Connection
3	INHIBIT	This is an open collector input. Logic Low = Disabled Output. Connect the inhibit pin to input common to disable the output. Unconnected, open collector or open drain = Enabled Output.
4	INCOM	Input Return Connection
5	INCOM	Input Return Connection
6	OUTCOM	Output Return Connection
7	OUTCOM	Output Return Connection
8	CASE	Case Connection
9	VOUT	Positive Output Voltage Connection
10	VOUT	Positive Output Voltage Connection

100% ENVIRONMENTAL SCREENING

Screening	Condition
Internal Visual	IPC-A-610, Class 3
Temperature Cycling	MIL-STD-883, Method 1010, Condition B, -55°C to +125°C, 10 Cycles
Burn-In	96 hours at +105°C
Final Electrical	100% at 25°C
External Visual	Internal Procedure

ORDERING INFORMATION

VPTc10-	28	W
1	2	3

(1) Product Series	(2) Nominal Input Voltage		(3) Package Option	
VPTc10-	28	28 Volts	None W	Standard Metal Epoxy Encapsulated

CONTACT INFORMATION

To request a quotation or place orders please contact your sales representative or the VPT Inc. Sales Department at:

Phone: (425) 353-3010
Fax: (425) 353-4030
E-mail: vptsales@vptpower.com

All information contained in this datasheet is believed to be accurate, however, no responsibility is assumed for possible errors or omissions. The products or specifications contained herein are subject to change without notice. VPT, its logo and tagline are registered trademarks in the U.S. Patent and Trademark Office.