

# VPTi10-28 Series

## HIGH RELIABILITY COTS EMI FILTER / TRANSIENT PROTECTION MODULE

### DESCRIPTION

The VPTi10-28 input module is a combined EMI filter and voltage transient protection module with built-in reverse polarity protection. Compatible with VPT's DV and VPT series isolated DC-DC converters, the VPTi10-28 provides compliance for both MIL-STD-704 and MIL-STD-1275 input power requirements for avionics, mobile, ground systems, and other applications. The VPTi10-28 also reduces the reflected noise of the DC-DC converters to meet MIL-STD-461 requirements for conducted emissions and protects the converters from conducted susceptibility. A proven design heritage, no optoisolators and a rugged all metal or optional epoxy encapsulated package ensure long term reliability.

The VPTi10-28 intended for harsh environments including severe vibration, shock and temperature cycling. Testing is to JESD22, MIL-STD-810, and MIL-STD-883.

These converters are designed and manufactured in a facility certified to ISO9001, J-STD-001 and IPC-A-610.

This product may incorporate one or more of the following U.S. patents:

- 5,784,266
- 5,790,389
- 5,963,438
- 5,999,433
- 6,005,780
- 6,084,792
- 6,118,673

### FEATURES

- High Reliability at Low Cost
- Up to 10 Amps of Output Current
- Up to 200W of Output Power
- Wide Input Voltage Range
- Transient Operation up to 80 Volts per MIL-STD-704 and 100 Volts per MIL-STD-1275
- 45 dB Minimum Attenuation at 500 kHz
- Provides Inrush Current Limiting
- True Reverse Polarity Protection
- Wide Temperature Range, -55°C to 105°C
- Internally Conformal Coated
- Standard Six Sided Non-Hermetic Rugged Metal Package
- Optional Six Sided Rugged Epoxy Encapsulated Package with Integral Metalized EMI shield that is fully compatible with aqueous cleaning processes
- Meets MIL-STD-461C/D/E Conducted Emissions Requirements When Used With a VPT Series DC-DC Converter
- Meets Conducted Susceptibility Requirements of MIL-STD-461C, CS01 and CS02, and MIL-STD-461D/E when used with a VPT Series DC-DC Converter



Figure 1 – VPTi10-28 Input Module Standard Metal Package



Figure 2 – VPTi10-28W Input Module Optional Epoxy Encapsulated Package

(Not to scale)



## SPECIFICATIONS (T<sub>CASE</sub> = -55°C to +105°C, V<sub>IN</sub> = +28V ± 5%, Full Load, Unless Otherwise Specified)

### ABSOLUTE MAXIMUM RATINGS

Input Voltage (Continuous)	40 V <sub>DC</sub>	Junction Temperature Rise to Case	+15°C
Input Voltage (Transient, 100 ms)	100 Volts	Storage Temperature	-55°C to +125°C
Output Current	10 Amps	Lead Solder Temperature (10 seconds)	300°C
Power Dissipation (Full Load, T <sub>CASE</sub> = +105°C)	12 Watts	Weight (Maximum)	66 Grams

Parameter	Conditions	VPTi10-28			Units	
		Min	Typ	Max		
<b>STATIC</b>						
INPUT Voltage	Continuous	-40	28	40	V	
	Transient	1 sec <sup>2</sup>	-	50	V	
	Transient	100 ms, 500 mΩ	-	100	V	
	Transient	70 μs, 15 mJ	-250	-	250	V
	Transient	10 μs, 50Ω	-	-	600	V
Current	Inhibited	-	-	10	mA	
Inrush Current <sup>2</sup>	V <sub>in</sub> = 0 to 28V, Full Load	-	5	10	A	
Inhibit Pin Input <sup>2</sup>		0	-	1.5	V	
Inhibit Pin Open Circuit Voltage <sup>2</sup>		10	12	16	V	
UVLO Turn On		-	9	11	V	
UVLO Turn Off <sup>2</sup>		5	8	-	V	
OUTPUT Voltage	Continuous	0	-	40	V	
	Transient	0	-	50	V	
Current <sup>1</sup>		0	-	10	A	
Power <sup>1</sup>		0	-	200	W	
DC RESISTANCE		-	50	120	mΩ	
NOISE REJECTION	f = 500 kHz	45	65	-	dB	
CAPACITANCE	Any Pin to Case	57	-	135	nF	
CASE ISOLATION	1500 V <sub>DC</sub>	100	-	-	MΩ	
MTBF (MIL-HDBK-217F)	GM @ T <sub>C</sub> = 55°C	-	501	-	kHrs	
<b>DYNAMIC</b>						
Turn On Delay	V <sub>IN</sub> = 0V to 28V	-	4	10	mSec	

- Notes:
1. Derate linearly to 0 at 115°C
  2. Verified by qualification testing

## BLOCK DIAGRAM

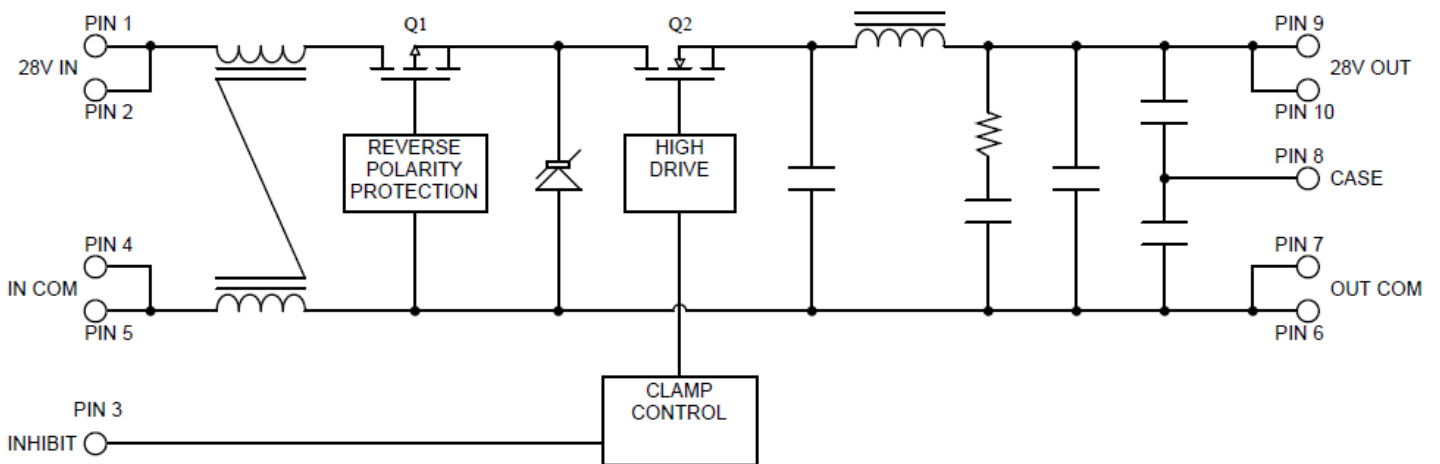

Figure 3

## CONNECTION DIAGRAM

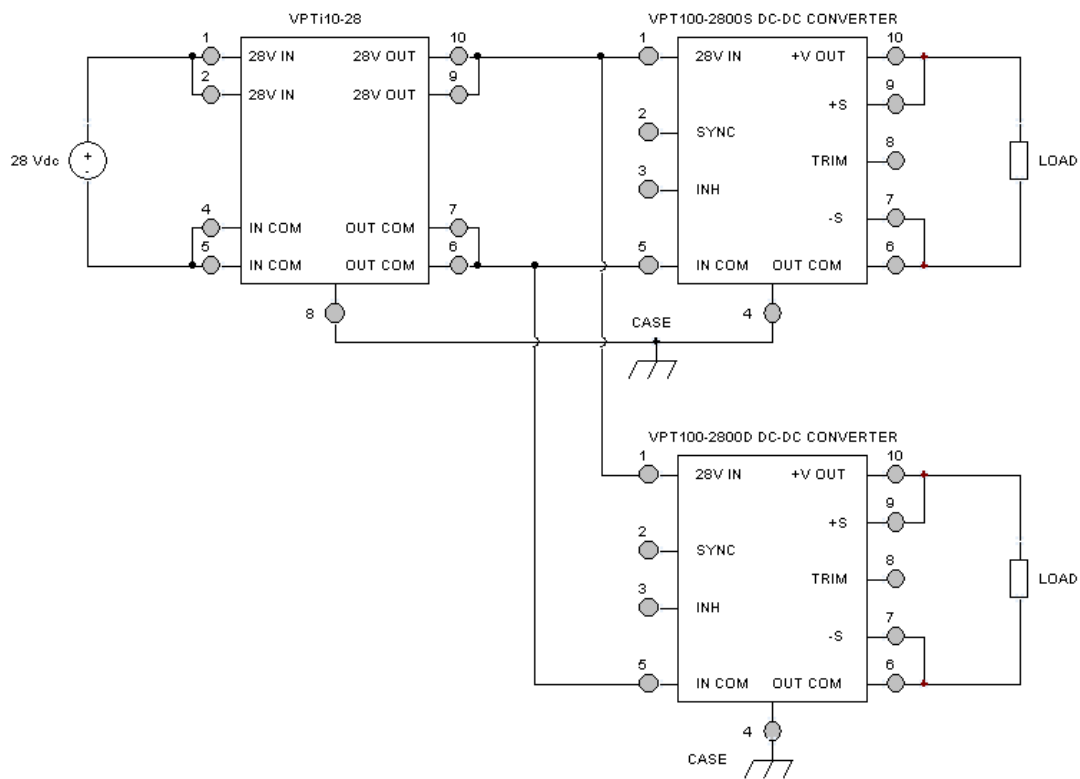
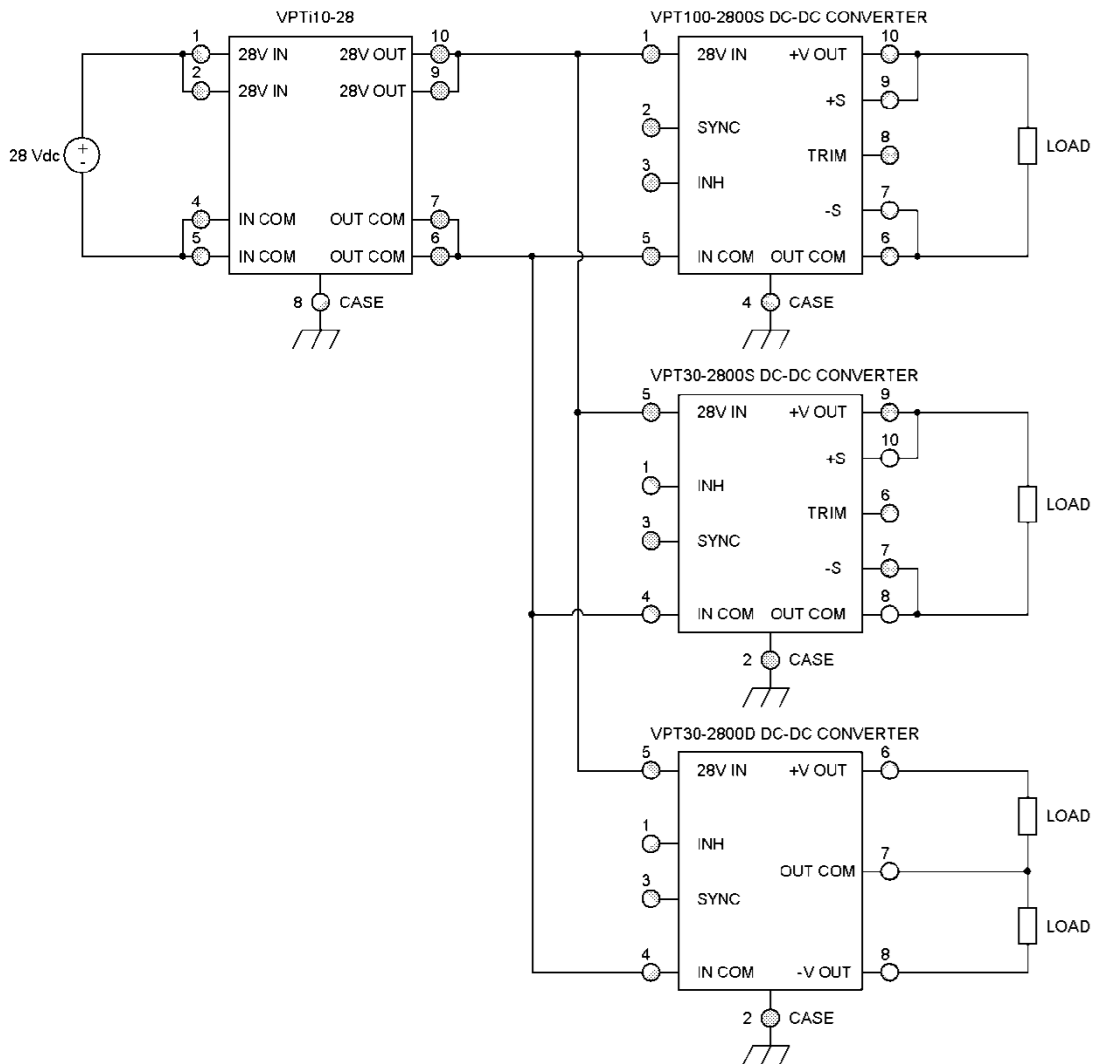

Figure 4

(Shown with Two VPT100-2800S&D Series DC-DC Converters)

## CONNECTION DIAGRAM



**Figure 5**

(Shown with VPT100-2800S & VPT30-2800S&D Series DC-DC Converters)

## PERFORMANCE CURVES

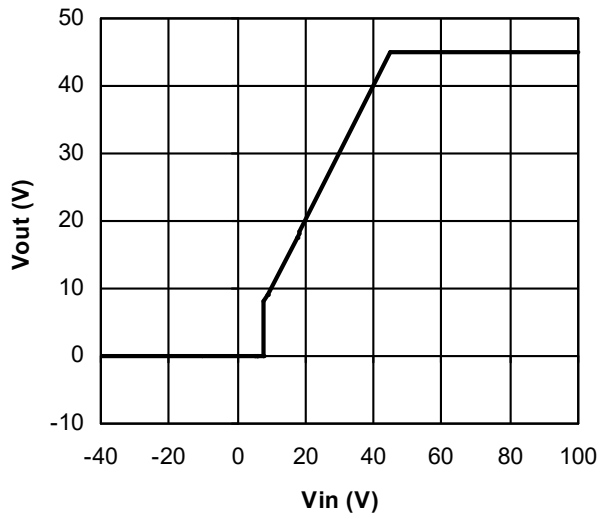

Figure 6 – Output Voltage vs Input Voltage

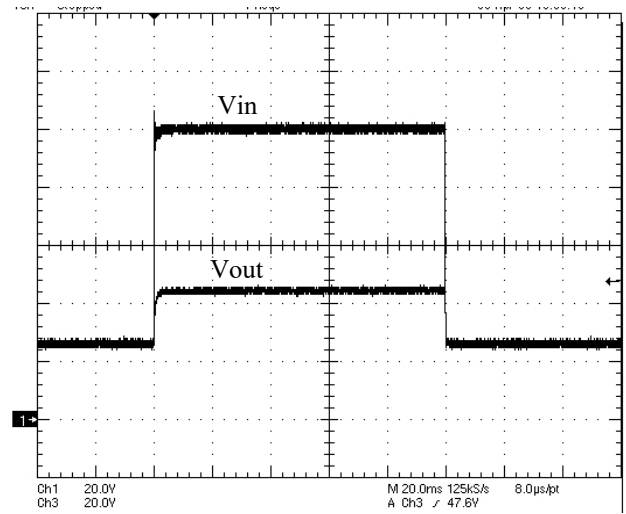

Figure 7 – Vin, Vout during 100V, 100ms Transient

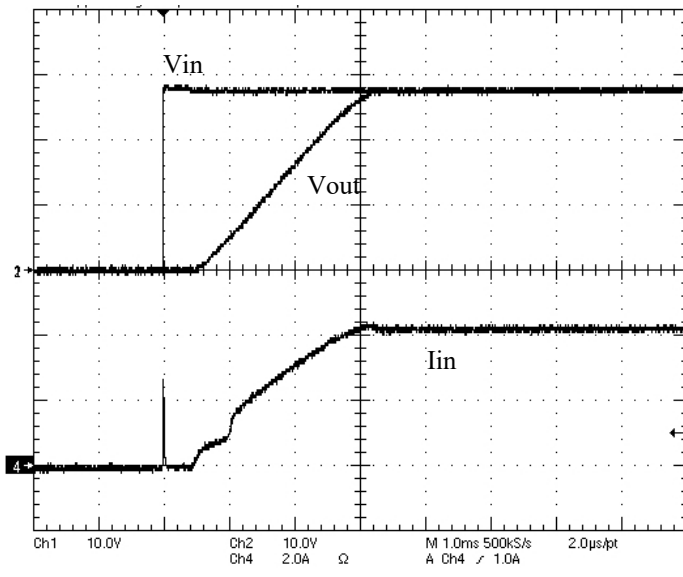
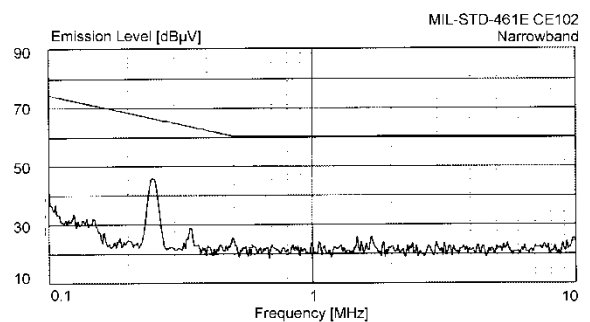
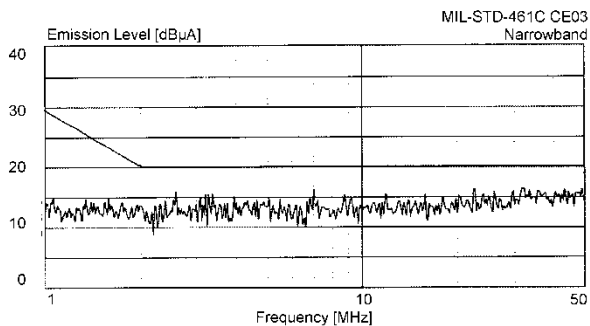
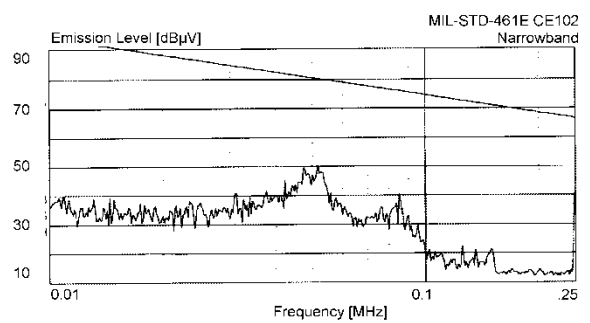
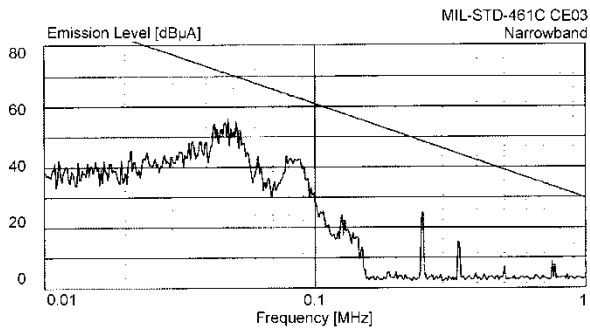

Figure 8 – Vout, Iin (inrush current) during turn-on

## EMI PERFORMANCE CURVES

( $T_{CASE} = 25^{\circ}C$ ,  $V_{IN} = +28V \pm 5\%$ , Full Load, Unless Otherwise Specified)



**Figure 9 – MIL-STD-461C**  
Two VPT100-2800S With VPTi10-28 Input Module

**Figure 10 – MIL-STD-461D/E**  
Two VPT100-2800S With VPTi10-28 Input Module

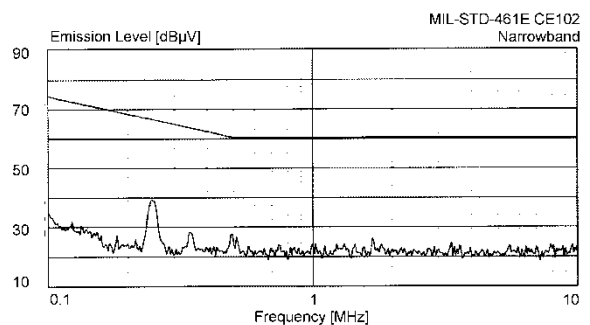
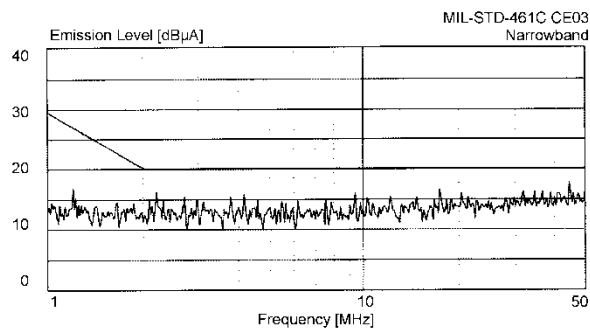
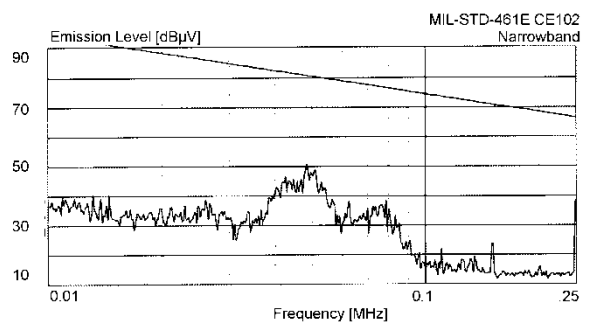
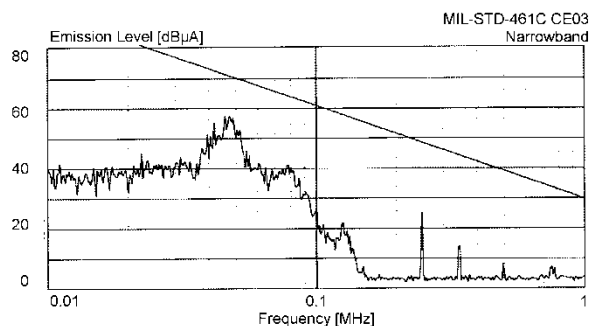

**Figure 11 – MIL-STD-461C**  
Two VPT30-2800S and One VPT100-2800S  
With VPTi10-28 Input Module

**Figure 12 – MIL-STD-461D/E**  
Two VPT30-2800S and One VPT100-2800S  
With VPTi10-28 Input Module

## STANDARD METAL PACKAGE

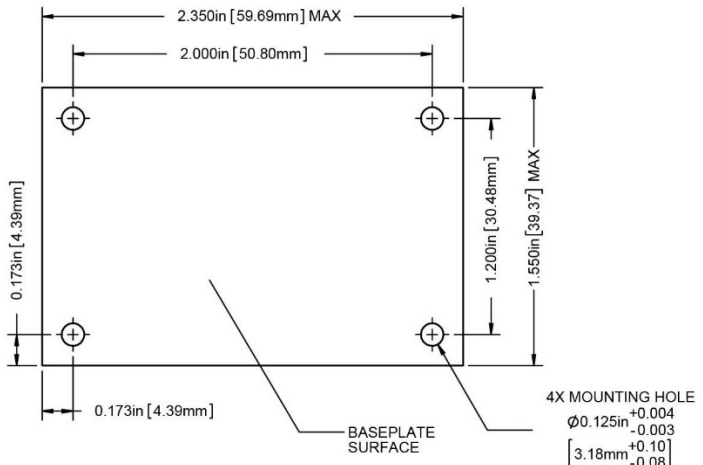
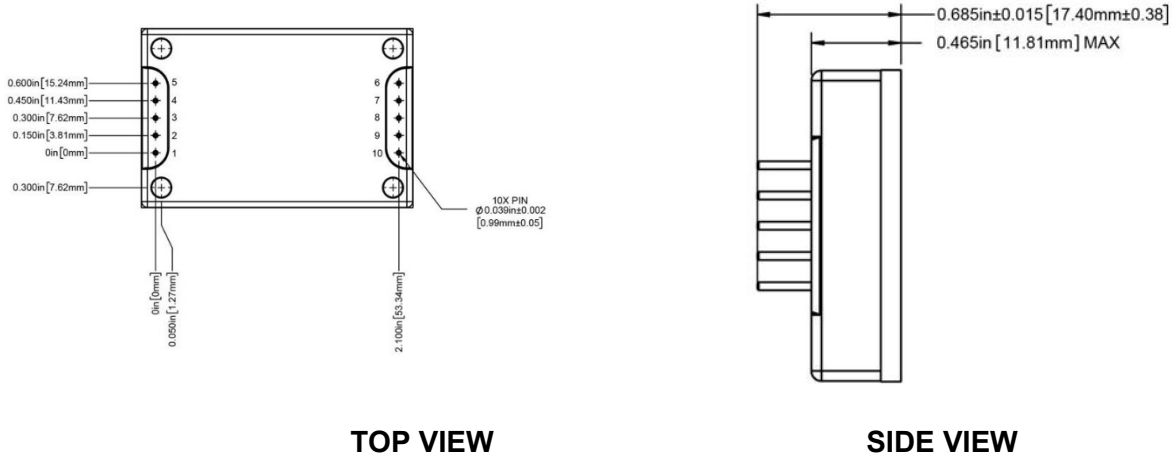

Pin	Function
1	VIN
2	VIN
3	INHIBIT
4	INCOM
5	INCOM
6	OUTCOM
7	OUTCOM
8	CASE
9	VOUT
10	VOUT

**Figure 13 – Package and Pinout**  
(Dimensional Limits are ±0.005” Unless Otherwise Stated)

### Package Notes

- Case temperature is measured on the center of the baseplate surface.
- Materials: Baseplate – aluminum, conductive conversion coating.  
Cover – brass, nickel plated.  
Pins - copper, gold over nickel plating.
- Mounting holes are not threaded. Recommended fastener is 4-40.
- This Package is not hermetic. VPT offers a wide range of hermetic products. Please contact VPT for details if hermetic products are required.

## OPTIONAL EPOXY ENCAPSULATED PACKAGE

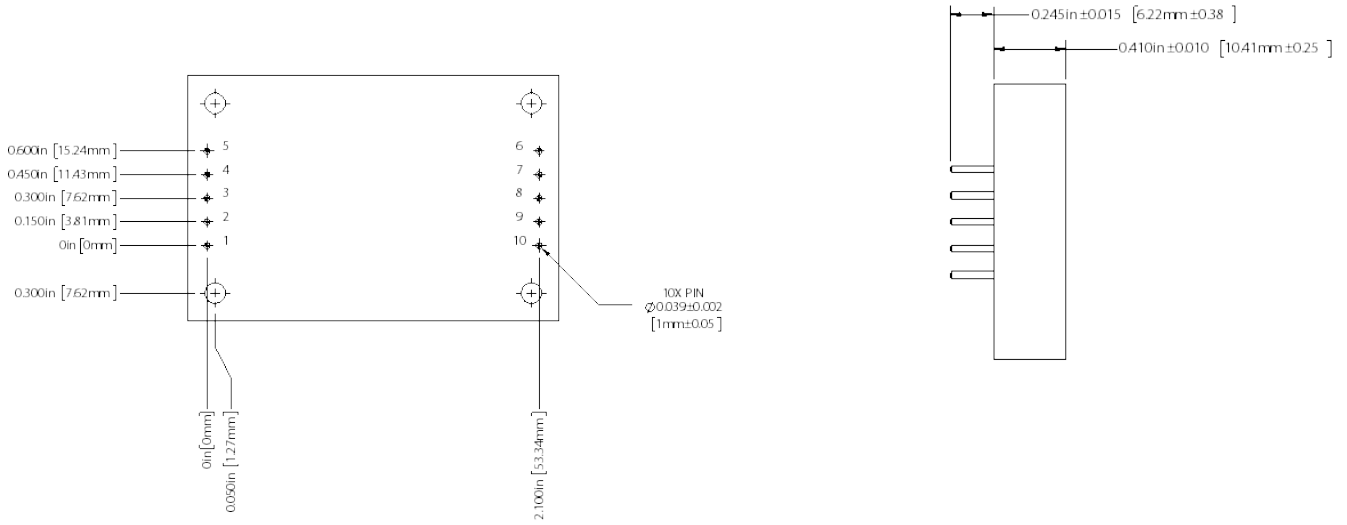

**TOP VIEW**

**SIDE VIEW**

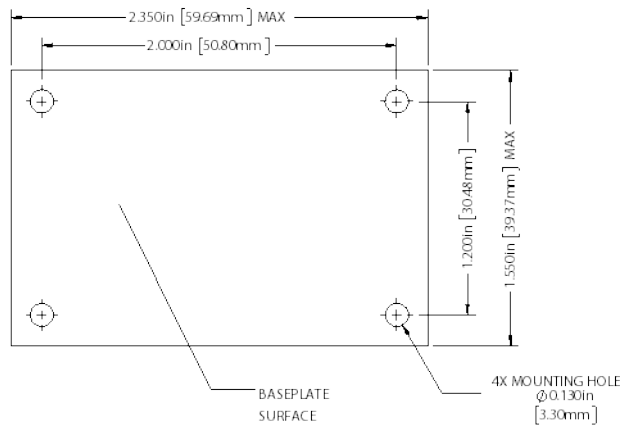

**BOTTOM VIEW**

Pin	Function
1	VIN
2	VIN
3	INHIBIT
4	INCOM
5	INCOM
6	OUTCOM
7	OUTCOM
8	CASE
9	VOUT
10	VOUT

**Figure 14 – Package and Pinout**  
(Dimensional Limits are  $\pm 0.010$ " Unless Otherwise Stated)

### Package Notes

- Case temperature is measured on the center of the baseplate surface.
- Materials: Body - epoxy with integral metalized EMI shield.  
Pins - copper, gold over nickel plating.
- Mounting holes are not threaded. Recommended fastener is 4-40.
- This package is highly resistant to chemical, solvent and salt environments and is fully compatible with high volume manufacturing processes including wave solder, cleaning solvents, high pressure sprays and aqueous wash processes.

**PACKAGE PIN DESCRIPTION**

Pin	Function	Description
1	VIN	Positive Input Voltage Connection
2	VIN	Positive Input Voltage Connection
3	INHIBIT	This is an open collector input. Logic Low = Disabled Output. Connect the inhibit pin to input common to disable the output. Unconnected, open collector or open drain = Enabled Output.
4	INCOM	Input Return Connection
5	INCOM	Input Return Connection
6	OUTCOM	Output Return Connection
7	OUTCOM	Output Return Connection
8	CASE	Case Connection
9	VOUT	Positive Output Voltage Connection
10	VOUT	Positive Output Voltage Connection

**100% ENVIRONMENTAL SCREENING**

Screening	Condition
Internal Visual	IPC-A-610, Class 3
Stabilization Bake	MIL-STD-883, Method 1008, Condition B, 125°C, 24 hours
Temperature Cycling	MIL-STD-883, Method 1010, Condition B, -55°C to +125°C, 10 Cycles
Burn-In	96 hours at +105°C
Final Electrical	100% at 25°C
External Visual	Internal Procedure

## ORDERING INFORMATION

VPTi10-	28	W
1	2	3

(1)	(2)		(3)	
Product Series	Nominal Input Voltage		Package Option	
VPTi10-	28	28 Volts	None W	Standard Metal Epoxy Encapsulated

## CONTACT INFORMATION

To request a quotation or place orders please contact your sales representative or the VPT Inc. Sales Department at:

**Phone:** (425) 353-3010  
**Fax:** (425) 353-4030  
**E-mail:** [vptsales@vptpower.com](mailto:vptsales@vptpower.com)

All information contained in this datasheet is believed to be accurate, however, no responsibility is assumed for possible errors or omissions. The products or specifications contained herein are subject to change without notice. VPT, its logo and tagline are registered trademarks in the U.S. Patent and Trademark Office.