



Power Your Critical Mission Today

# VSC5-2800D SERIES

## RADIATION TOLERANT DC-DC CONVERTERS



VSC5-2800D - Exact marking may differ from that shown

### Models Available

Input: 15 V to 50 V continuous, 80 V transient

Dual outputs:  $\pm 5$  V,  $\pm 12$  V, or  $\pm 15$  V

Wattage: 5 W

### 1.0 DESCRIPTION

The VSC5-2800D Series is a commercial off the shelf DC-DC converter designed for the 'NewSpace' market. Performance is guaranteed through the use of radiation lot acceptance tested (RLAT) components. Our proprietary packaging creates a dual side heatsinking option with very low outgassing.

Radiation tested to 42 MeV/mg/cm<sup>2</sup> with no destructive SEE events (SEGR, SEB, and SEL) and tested to 40 krad(Si), guaranteed to 30 krad(Si), for TID in accordance with VPT's inhouse radiation hardness assurance (RHA) plan.

The VSC5-2800D Series are designed for smaller satellites in low Earth orbits (LEO), and NASA Class D missions where the balance of cost and guaranteed performance is critical.

### 1.1 FEATURES

- Output Voltage  $\pm 5$  V,  $\pm 12$  V,  $\pm 15$  V
- Wide input voltage range: 15 V to 50 V plus 80 V transient
- Continuous operation over full military temperature range of -55 °C to +105 °C with no power derating
- Fixed frequency
- Very low output noise
- No use of optoisolators
- Undervoltage lockout

### 1.2 SPACE LEVEL CHARACTERIZATIONS

- Guaranteed TID performance to 30 krad(Si) including LDR
- SEE tested to 42 MeV/mg/cm<sup>2</sup>. Transients are fully analyzed for cross-section and magnitude at 30 MeV/mg/cm<sup>2</sup>
- Radiation Hardness Assurance, see Section 6.5 herein
- Mean Time Between Failures (MTBF) calculations available
- Failure In Time (FIT) numbers available

### 1.3 MANUFACTURING AND COMPLIANCE

- Manufactured in an ISO9001, J-STD-001, and IPC-A-610 certified facility
- MIL-STD-461 C-G conducted emissions when used with the appropriate VPT EMI filter

### 1.4 PACKAGING

- Low-profile: 1.110" x 1.110" x 0.360"
- Max weight: 24 g
- Outgassing less than 1.5% TML and 0.12% CVCM

### 1.5 ACCESSORIES

- VSCF1-28 EMI filter
- Use with Thermal Pad TP-008 or TP2-008

## 2.0 DIAGRAMS

### 2.1 BLOCK DIAGRAM

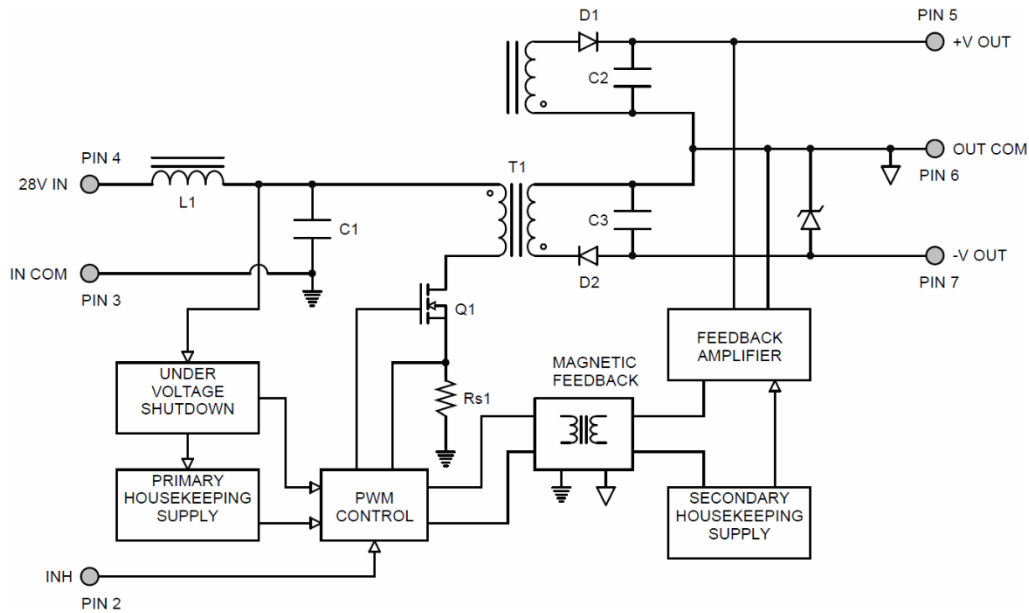

### 2.2 CONNECTION DIAGRAM

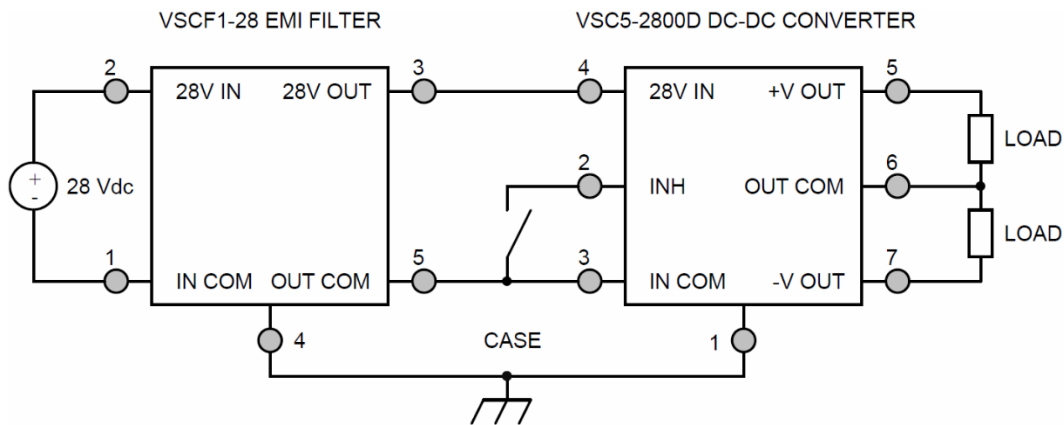

## 3.0 SPECIFICATIONS

### 3.1 ABSOLUTE MAXIMUM RATINGS

Absolute Maximum Ratings			
Input Voltage (Continuous):	-0.5 V to 50 V	Operating Temperature (Full Load):	-55 °C to +105 °C
Input Voltage (Transient, 1 second):	-0.5 V to 80 V	Storage Temperature:	-55 °C to +125 °C
		Lead Solder Temperature (10 seconds):	300 °C

## 3.2 PERFORMANCE SPECIFICATIONS

Tcase = -55 °C to +105 °C, Vin = +28 V ± 5%, Full Load<sup>4</sup>, Unless Otherwise Specified

Parameter	Conditions	VSC5-2805D			VSC5-2812D			Units
		Min	Typ	Max	Min	Typ	Max	
<b>INPUT</b>								
Voltage	Continuous	15	28	50	15	28	50	V
	Transient, 1 sec <sup>3</sup>	-	-	80	-	-	80	V
Current	INH < 1.5 V	-	4	6	-	4	6	mA
	No Load	-	40	70	-	40	70	mA
Ripple Current	20 Hz to 10 MHz	-	30	60	-	30	60	mApp
Undervoltage Lockout	Turn On	12	-	14.8	12	-	14.8	V
	Turn Off <sup>3</sup>	11	-	14.5	11	-	14.5	V
<b>OUTPUT STATIC</b>								
Voltage	+Vout, Tcase = 25 °C	4.92	5	5.08	11.70	12	12.30	V
	+Vout, Tcase = -55 °C to 105 °C	4.87	5	5.13	11.58	12	12.42	V
	-Vout, Tcase = 25 °C	4.87	5	5.13	11.70	12	12.30	V
	-Vout, Tcase = -55 °C to 105 °C	4.82	5	5.18	11.58	12	12.42	V
Power <sup>2,5</sup>	Total	0	-	5	0	-	5	W
	Either Output	0	-	3.5	0	-	3.5	W
Current <sup>2,5</sup>	Total	0	-	1	0	-	0.42	A
	Either Output	0	-	0.7	0	-	0.39	A
Ripple Voltage	20 Hz to 10 MHz	-	50	95	-	35	75	mVpp
Line Regulation	+Vout, Vin = 15 V to 50 V	-	1	20	-	5	20	mV
	-Vout, Vin = 15 V to 50 V	-	10	50	-	30	150	mV
Load Regulation <sup>6</sup>	+Vout, No Load to Full Load	-	1	20	-	5	20	mV
	-Vout, No Load to Full Load	-	20	100	-	55	200	mV
Cross Regulation, -Vout	+Vout: 70% load, -Vout: 30% load	-	150	300	-	200	300	mV
	+Vout: 30% load, -Vout: 70% load	-	150	300	-	200	300	mV
<b>OUTPUT DYNAMIC</b>								
Load Step, Half to Full Load	Output Transient	-	65	150	-	100	200	mVpk
	Recovery <sup>1</sup>	-	150	300	-	200	500	µs
Line Step <sup>3</sup> , Vin = 16 V to 40 V	Output Transient	-	20	50	-	55	120	mVpk
	Recovery <sup>1</sup>	-	-	40	-	-	80	µs
Turn On, Vin = 0 to 28 V	Delay	-	10	20	-	10	20	ms
	Overshoot	-	0	25	-	0	50	mVpk
<b>FUNCTION</b>								
INH Pin Input <sup>3</sup>	Output Inhibited	0	-	1.5	0	-	1.5	V
INH Pin Open Circuit Voltage <sup>3</sup>	Output Enabled	9	-	13	9	11	13	V
<b>GENERAL</b>								
Efficiency		64	72	-	66	74	-	%
Capacitive Load <sup>3</sup>	Either Output	-	-	300	-	-	100	µF
Switching Frequency		425	500	550	425	500	550	kHz
Isolation	500 V DC, Tcase = 25 °C	100	-	-	100	-	-	MΩ
Weight		-	-	24	-	-	24	g
MTBF (MIL-HDBK-217F)	SF @ Tcase = 25 °C	-	-	-	-	-	-	MHr
	SF @ Tcase = 55 °C	-	7.52	-	-	7.52	-	MHr
	SF @ Tcase = 85 °C	-	-	-	-	-	-	MHr
<b>POST-RAD LIMITS<sup>7</sup></b>								
Output Voltage	+Vout, Tcase = -55 °C to +105 °C	4.77	5	5.23	11.34	12	12.66	V
	- Vout, Tcase = -55 °C to +105 °C	4.72	5	5.28	11.34	12	12.66	V
Line Regulation	+Vout, Vin = 15 V to 50 V	-	1	25	-	1	25	mV
Load Regulation <sup>6</sup>	+Vout, No Load to Full Load	-	1	25	-	1	25	mV

1. Time for output voltage to settle within 1% of steady-state value.

2. Derate linearly to 0 at 115°C.

3. Verified by initial electrical design verification. Post design verification, parameter shall be guaranteed to the limits specified.

4. Half load at +Vout and half load at -Vout.

5. Up to 70% of the total power or current can be drawn either of the two outputs.

6. 5% Load to Full Load at -55°C.

7. Post-RAD limits are within standard limits except where noted.

## 3.2 PERFORMANCE SPECIFICATIONS

Tcase = -55 °C to +105 °C, Vin = +28 V ± 5%, Full Load<sup>4</sup>, Unless Otherwise Specified

		VSC5-2815D			
Parameter	Conditions	Min	Typ	Max	Units
<b>INPUT</b>					
Voltage	Continuous	15	28	50	V
	Transient, 1 sec <sup>3</sup>	-	-	80	V
Current	INH < 1.5 V	-	4	6	mA
	No Load	-	40	70	mA
Ripple Current	20 Hz to 10 MHz	-	30	60	mApp
Undervoltage Lockout	Turn On	12	-	14.8	V
	Turn Off <sup>3</sup>	11	-	14.5	V
<b>OUTPUT STATIC</b>					
Voltage	+Vout, Tcase = 25 °C	14.62	15	15.38	V
	+Vout, Tcase = -55 °C to 105 °C	14.47	15	15.53	V
	-Vout, Tcase = 25 °C	14.62	15	15.38	V
	-Vout, Tcase = -55 °C to 105 °C	14.47	15	15.53	V
Power <sup>2,5</sup>	Total	0	-	5	W
	Either Output	0	-	3.5	W
Current <sup>2,5</sup>	Total	0	-	0.33	A
	Either Output	0	-	0.23	A
Ripple Voltage	20 Hz to 10 MHz	-	35	75	mVpp
Line Regulation	+Vout, Vin = 15 V to 50 V	-	5	20	mV
	-Vout, Vin = 15 V to 50 V	-	30	150	mV
Load Regulation <sup>6</sup>	+Vout, No Load to Full Load	-	5	20	mV
	-Vout, No Load to Full Load	-	55	200	mV
Cross Regulation, -Vout	+Vout: 70% load, -Vout: 30% load	-	200	300	mV
	+Vout: 30% load, -Vout: 70% load	-	200	300	mV
<b>OUTPUT DYNAMIC</b>					
Load Step, Half Load to Full Load	Output Transient	-	100	200	mVpk
	Recovery <sup>1</sup>	-	200	500	µs
Line Step <sup>3</sup> , Vin = 16 V to 40 V	Output Transient	-	55	150	mVpk
	Recovery <sup>1</sup>	-	-	80	µs
Turn On, Vin = 0 V to 28 V	Delay	-	10	20	ms
	Overshoot	-	0	50	mVpk
<b>FUNCTION</b>					
INH Pin Input <sup>3</sup>	Output Inhibited	0	-	1.5	V
INH Pin Open Circuit Voltage <sup>3</sup>	Output Enabled	9	11	13	V
<b>GENERAL</b>					
Efficiency		67	75	-	%
Capacitive Load <sup>3</sup>	Either Output	-	-	100	µF
Switching Frequency		425	500	550	kHz
Isolation	500 VDC, Tcase = 25 °C	100	-	-	MΩ
Weight		-	-	24	g
MTBF (MIL-HDBK-217F)	SF @ Tcase = 55 °C	-	7.52	-	MHr
<b>POST-RAD LIMITS<sup>7</sup></b>					
Output Voltage	+Vout, Tcase = -55 °C to +105 °C	14.17	15	15.83	V
	-Vout, Tcase = -55 °C to +105 °C	14.17	15	15.83	V
Line Regulation	+Vout, Vin = 15 V to 50 V	-	1	25	mV
Load Regulation <sup>6</sup>	+Vout, No Load to Full Load	-	1	25	mV

1. Time for output voltage to settle within 1% of steady-state value.

2. Derate linearly to 0 at 115°C.

3. Verified by initial electrical design verification. Post design verification, parameter shall be guaranteed to the limits specified.

4. Half load at +Vout and half load at -Vout.

5. Up to 70% of the total power or current can be drawn either of the two outputs.

6. 5% Load to Full Load at -55°C.

7. Post-RAD limits are within standard limits except where noted.

## 4.0 PERFORMANCE CURVES

### 4.1.1 VSC5-2805D Efficiency (Typical, 25 °C)

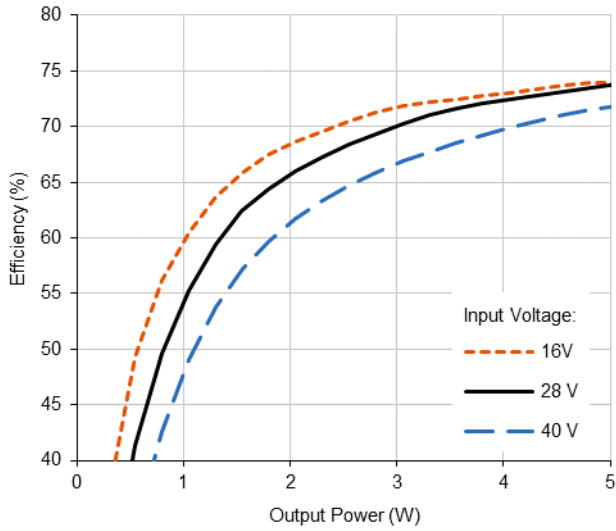

### 4.1.2 VSC5-2812D Efficiency (Typical, 25 °C)

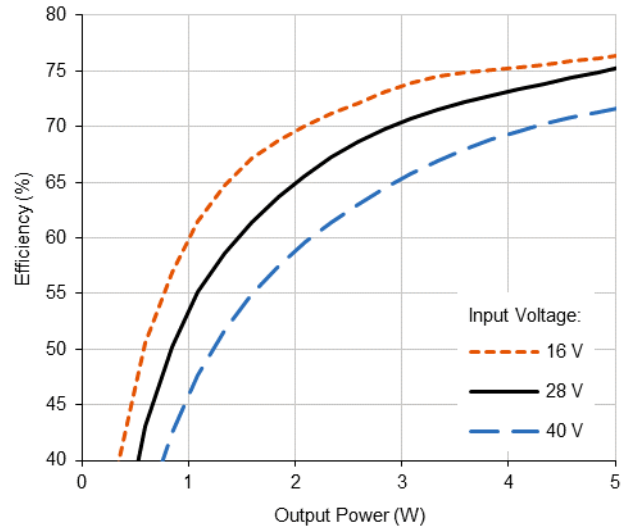

### 4.1.3 VSC5-2815D Efficiency (Typical, 25 °C)

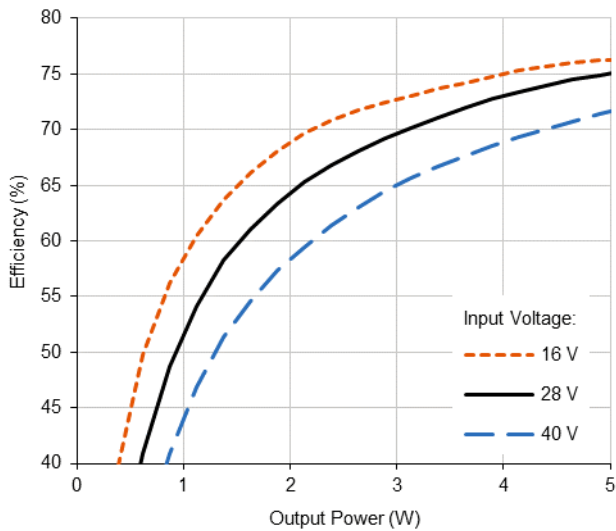

## 4.0 PERFORMANCE CURVES (CONTINUED)

### 4.2.1 VSC5-2805D Cross-Regulation (Typical, 25 °C)

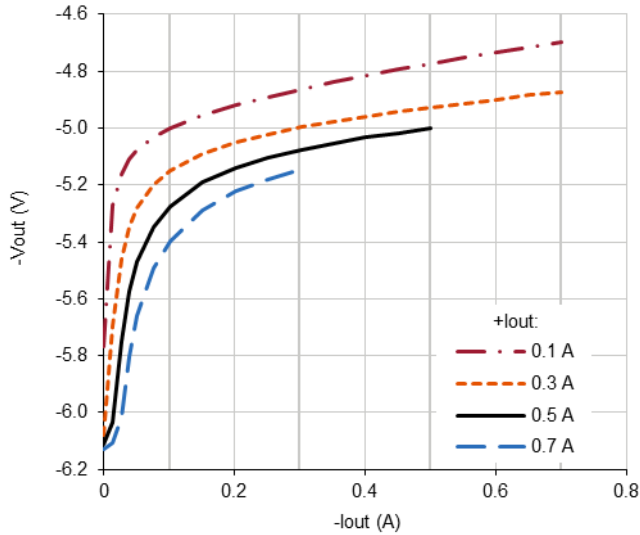

### 4.1.2 VSC5-2812D Cross-Regulation (Typical, 25 °C)

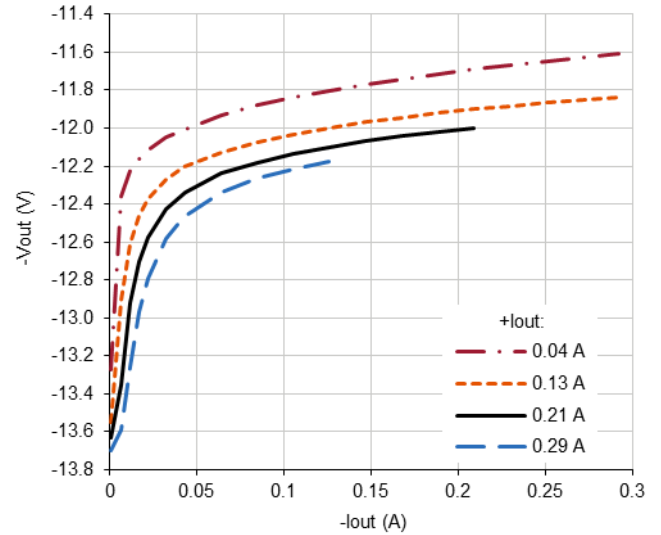

### 4.1.3 VSC5-2815D Cross-Regulation (Typical, 25 °C)

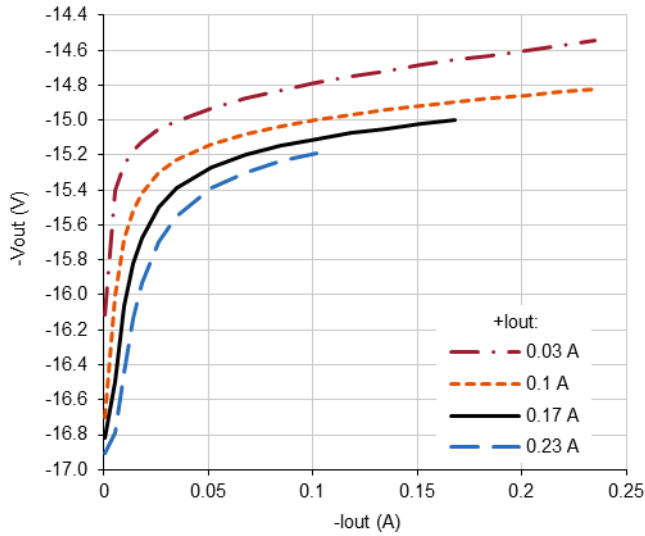

## 5.0 MECHANICAL OUTLINES AND PINOUT

Standard Package Option:

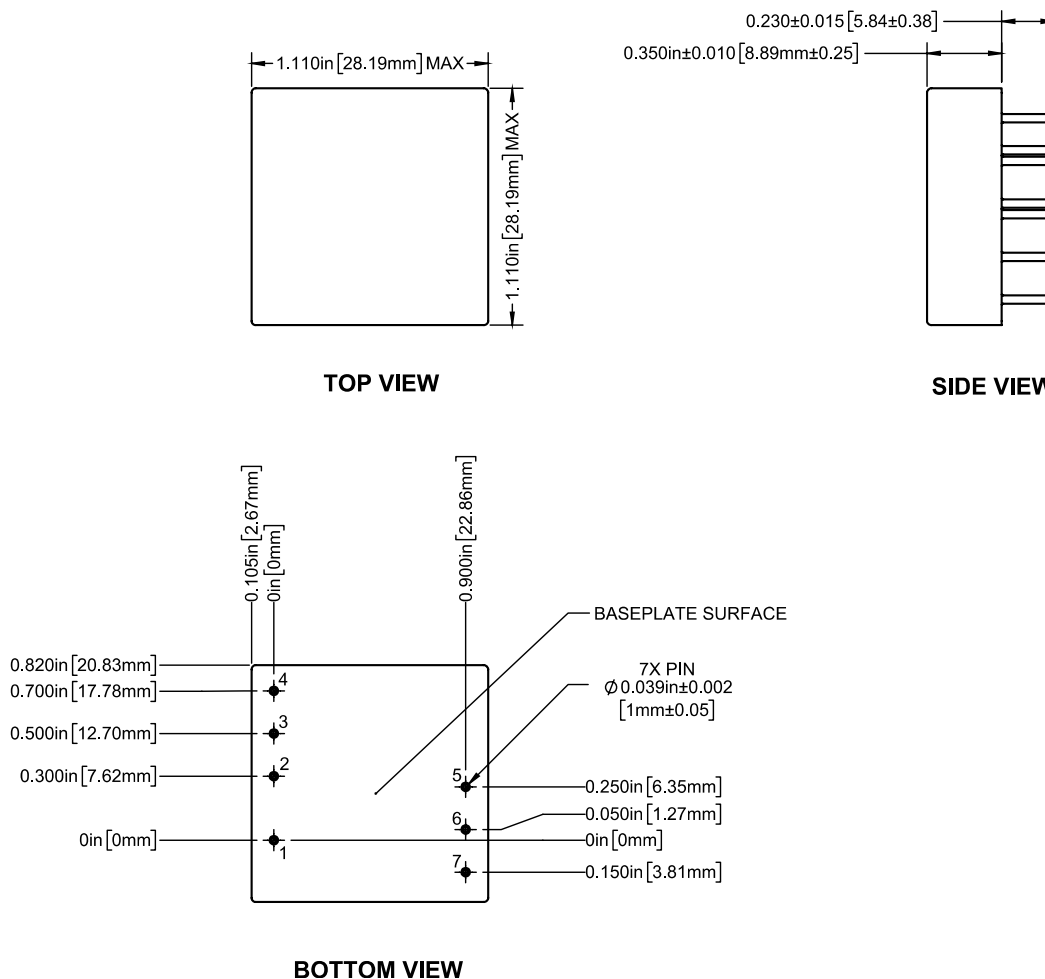

1. Tolerances are ±0.005" unless otherwise stated
2. Case temperature is measured on the center of the baseplate surface
3. Materials: Body (Epoxy); Pin (Tellurim Copper, alloy 145, gold over nickel plating)

Pin	Function	Pin	Function
1	CASE	5	+VOUT
2	INH	6	OUTCOM
3	INCOM	7	-VOUT
4	28VIN		

## 6.0 TECHNICAL NOTES

Please note that many of these functions are also demonstrated in detail on the VPT website in the form of technical video labs.

### 6.1 GENERAL INFORMATION

#### 6.1.1 Topology Description

The VSC5-2800D Series is an isolated dual-output flyback converter. It provides a positive and negative output voltage with respect to the OUTCOM pin. Up to 70% of the total output power is available from either output. The internal voltage regulation loop actively regulates the positive output using VPT's proprietary magnetic feedback technology. The negative output is regulated by cross-regulation of the transformer windings. The negative output is well-regulated for balanced load conditions. For unbalanced load conditions, refer to the cross-regulation performance graphs in Section 4.2 for expected performance. For a balanced or near-balanced load condition, the converter will regulate down to zero load, and no minimum load is required. For an unbalanced load condition, with negative loads greater than 10%, a minimum load of 10% is recommended on the positive output.

#### 6.1.2 External Components

The VSC5-2800D Series is designed to operate stand-alone in most applications. It does not require any external components for proper operation or to meet the datasheet specifications. Input and output L-C filters are provided internally for low ripple and noise. To further reduce output ripple and noise, a small ceramic capacitor, 1  $\mu\text{F}$  to 10  $\mu\text{F}$ , can be added at the output. Most application specific ripple requirements can be met with the addition of output capacitors alone. External output capacitance can be added up to the maximum listed in Section 3.2.

#### 6.1.3 Source Impedance

The impedance of the 28 V input source can interact with the DC-DC converter and can affect performance. High source impedance is often caused by a long input cable or components added in series with the input. Source resistance will cause a DC voltage drop as the converter draws DC input current. This voltage drop is simply the cable resistance multiplied by the input current at low line. The voltage drop and the actual voltage at the input to the converter will determine the minimum source voltage at which the converter will operate. A high source inductance can interact with the feedback control loop of the converter. VPT's EMI filters will usually isolate the source and eliminate this problem. In some cases, additional input capacitance will be needed to stabilize the system.

#### 6.1.4 Output Configurations

Since the converter is isolated, the outputs can be used as a traditional dual-output, with a positive and negative voltage referenced to OUTCOM, or as a single-ended output referenced to  $-V_{\text{OUT}}$  or  $+V_{\text{OUT}}$ . For example, the VSC5-2812D can provide +12 V and -12 V in the traditional dual output configuration, or can provide +24 V referenced to  $-V_{\text{OUT}}$ , or -24 V referenced to  $+V_{\text{OUT}}$  in single-ended configuration. In the single-ended configuration, the OUTCOM pin will be at +12 V relative to  $-V_{\text{OUT}}$ .

The outputs of multiple converters can be stacked in series to provide higher voltages. When outputs of multiple modules are stacked, they naturally share the load. For example, two VSC5-2812D converters can be stacked to provide a 48 V output at 10 W.

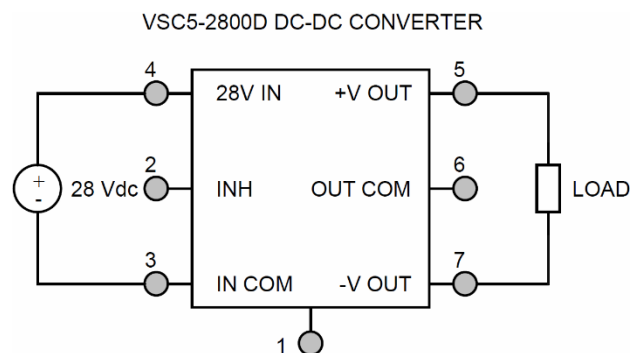

## 6.2 FUNCTION DESCRIPTIONS

### 6.2.1 On/Off Control (Inhibit)

The INH (Inhibit) pin is a primary-side control pin referenced to INCOM. The INH pin must be driven using an open collector or open drain configuration. Pulling the INH pin low disables the converter output, removes bias voltage from internal control circuitry, and puts the converter in a state of minimum input current draw. Leaving INH open enables the output, allowing the converter to operate normally. The pin must be pulled below 1.5 V to disable the output. An optional capacitor from INH to INCOM may be used to delay turn-on. The INH pin should be left open if not used.

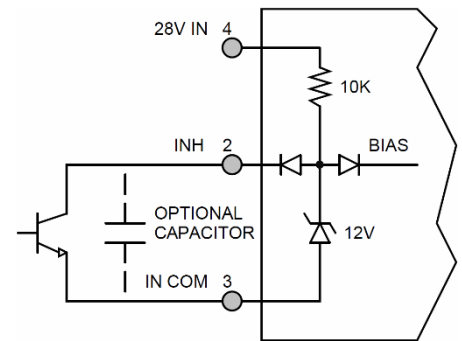

## 6.3 PROTECTION FEATURES

### 6.3.1 Input Undervoltage Lockout

The VSC5-2800D Series provides input undervoltage lockout protection. For input voltages below the turn-on voltage, the converter will remain off, drawing minimal current from the source. When the input voltage exceeds the turn-on voltage, the converter will start. The lockout circuit is designed to tolerate slow ramping input voltage waveforms.

### 6.3.2 Output Soft Start

The VSC5-2800D Series utilizes an output soft-start function to ramp the output in a controlled manner, eliminating output voltage overshoot and limiting inrush current at turn on. A voltage-mode soft-start ensures the output waveform remains consistent regardless of changes in the load current. The output rise time is approximately 8 ms. The soft-start function is active whether the module is turned on with an application of input voltage or from release of the inhibit pin. Under normal conditions, current drawn from the source during turn-on will not exceed the full-load input current. The turn-on delay time is specified from the application of input voltage (or release of the inhibit pin) until the output reaches 90% of its final value.

## 6.4 THERMAL CONSIDERATIONS

The VSC5-2800D Series is rated for full power operation at 105 °C. Operation above 105 °C is allowed at reduced power. Specifically, the output power should be derated linearly from full power at 105 °C to half power at 110 °C and to zero power at 115 °C. The operating temperature of the converter is specified on the baseplate or the top plate of the converter. The converter is designed to be conduction-cooled, with the baseplate or the top plate mounted to a heat sink, chassis, PCB or other thermal surface.

The DC-DC converter contains many semiconductor components. The maximum temperature rise from junction to case is 14 °C at full load.

## 6.5 RADIATION HARDNESS ASSURANCE

VPT takes a conservative approach to radiation testing to ensure product performance in a space environment. VPT's internal Space COTS Radiation Hardness Assurance (RHA) plan documents VPT's processes and procedures for assuring the performance of VPT Space COTS products under various environmental conditions in space including Total Ionizing Dose (TID) and Single-Event Effects (SEE). Additionally, the converters were characterized for Enhanced Low Dose Rate Sensitivity (ELDRS) by testing samples at 10 - 100 mrad(Si)/s to 40 krad(Si). Radiation tolerance is assured by a combination of both module-level characterization and sample HDR TID testing of sequestered lots of all sensitive semiconductor piece-parts used within the module.

### 6.5.1 Radiation Test and Performance Levels

Radiation Environment		Piece Part RLAT	Module-Level Characterization
Total Ionizing Dose (TID)	High Dose Rate (HDR)	40 krad(Si)	30 krad(Si)
	Low Dose Rate (LDR)	40 krad(Si)	30 krad(Si)
Single-Event Effects (SEE)	Destructive (SEB, SEGR, SEL)	Not applicable	≥ 42 MeV/mg/cm <sup>2</sup>
	Non-Destructive (SET, SEU, SEFI)	Not applicable	≥ 30 MeV/mg/cm <sup>2</sup>

### 6.5.2 RHA Plan Summary

Test	RHA Plan for VSC Series Isolated DC-DC Converters
Total Ionizing Dose (TID):	Sensitive semiconductor components undergo RLAT to 40 krad(Si) per MIL-STD-883 Method 1019. Converters are characterized to 30 krad(Si).
Enhanced Low Dose Rate Sensitivity (ELDRS):	Converters were tested at 10 - 100 mrad(Si)/s up to 40 krad(Si). Converters are characterized to 30 krad(Si).
Single Event Effects (SEE):	Converters are characterized to LET ≥ 42 MeV/mg/cm <sup>2</sup> for catastrophic events (SEL, SEB, SEGR) and to LET ≥ 30 MeV/mg/cm <sup>2</sup> for transients (SET) and functional interrupts (SEFI) under heavy ion exposure.
Radiation Lot Acceptance Testing (RLAT):	All production lots of sensitive semiconductor components undergo a sample test for TID at HDR.

## 7.0 ENVIRONMENTAL SCREENING

Test	/ES+
Internal Visual	IPC-A-610, Class 3
Temperature Cycling	MIL-STD-883, Method 1010, Condition B, -55°C to +125°C, 10 Cycles
Burn In	96 hours at +105 °C
Final Electrical <sup>1</sup>	-55 °C, 25 °C, 105 °C
External Visual	Internal Procedure

1. 100% R&R testing with all test data included in product shipment

## 8.0 ORDERING INFORMATION

<b>VSC5-</b>	<b>28</b>	<b>05</b>	<b>D</b>	<b>/ES+</b>
1	2	3	4	5

(1) Product Series	(2) Nominal Input Voltage	(3) Output Voltage	(4) Number of Outputs	(5) Screening Code
<b>VSC5-</b>	<b>28</b> 28 Volts	<b>05</b> 5 Volts <b>12</b> 12 Volts <b>15</b> 15 Volts	<b>D</b> Dual	<b>/ES+</b>

Please contact your sales representative or the VPT Inc. Sales Department for more information concerning additional environmental screening and testing, different input voltage, output voltage, power requirements, and source inspection.

## 10.0 CONTACT INFORMATION

To request a quotation or place orders please contact your sales representative or the VPT, Inc. Sales Department at:

**Phone:** (425) 353-3010  
**Fax:** (425) 353-4030  
**E-mail:** [vptsales@vptpower.com](mailto:vptsales@vptpower.com)

All information contained in this datasheet is believed to be accurate, however, no responsibility is assumed for possible errors or omissions. The products or specifications contained herein are subject to change without notice.

## 11.0 ADDITIONAL INFORMATION

Visit the VPT website for additional technical resources, including:

### [Product Catalogs](#)



### [Application Notes and White Papers](#)

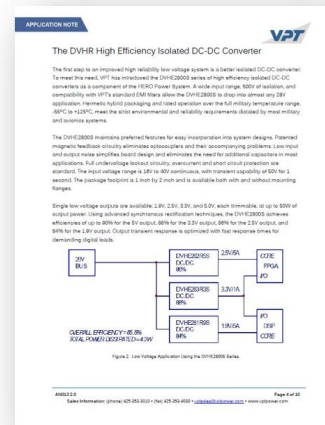

### [Technical Video Labs](#)



### [Additional Products For Avionics/Military, Hi-Rel COTS, and Space Applications](#)

