

Q-PAC

USER MANUAL

PREMIUM CONTROLS

V3.2.0

TABLE OF CONTENTS

SYSTEM OVERVIEW

SAFETY INFORMATION.....	8
RECEIVING AND HANDLING.....	9
SHORT TERM STORAGE.....	9
LONG TERM STORAGE.....	9
FAN LAYOUT.....	10
FAN ACCESSORIES	12
NAMEPLATES.....	14
CONTROL PANEL LAYOUT.....	16
FAN CONTROLLER LAYOUT.....	18
POWER HARMONICS.....	22
AIRFLOW MEASUREMENT.....	24

CONNECTING TO THE Q-PAC FAN

WIRING PREPARATION.....	28
FAN WIRING.....	30
FAN CONTROLLER BOARD	30
SINGLE FAN	32
MULTIPLE FANS	34
CONTROL PANEL WIRING.....	36
ELECTRICAL CHARACTERISTICS.....	38
TORQUE TIGHTENING REQUIREMENTS.....	40
START-UP AND TESTING.....	42

BACNET GUIDE

SPECIFICATIONS.....	46
OBJECT GUIDE.....	48

CONTROL PANEL HMI

- OVERVIEW..... 56
- USER ACCOUNTS..... 56
- SETTINGS MENU..... 61
- OPERATION SETTINGS..... 62
 - CONTROL SETTINGS 62
 - AIRFLOW PID SETTINGS 63
 - STATIC PRESSURE PID SETTINGS 64
 - RELAY AND RAMP SETTINGS 65
- SYSTEM SETTINGS..... 66
 - NETWORK SETTINGS 66
 - FIREMAN OVERRIDE 74
 - INTERLOCK SETTINGS 76
 - FAN LAYOUT SETTINGS 77
- ALARMS AND EVENTS..... 80
 - OVERVIEW 80
 - ALARMS 81
 - ACTIVE ALARM 82
 - ALARM CODES 83
 - EVENTS 84
 - CLEAR ALARMS / EVENTS 85
- PANEL CONFIGURATION..... 86
 - DATE AND TIME 86
 - OTHER SETTINGS 87

CONTROL PANEL HMI (CONTINUED)

STATUS MONITORING..... 88

 HOME SCREEN 88

 Q-PAC FAN STATUS 90

 POWER MONITORING 92

 NETWORK 93

 RELAY STATUS 94

MANUFACTURER SETTINGS..... 95

 SETUP 95

 OTHER SETTINGS 96

 HARDWARE CONFIGURATION SETTINGS 97

MAINTENANCE

INLET CONE ALIGNMENT..... 104

PLUG FAN REMOVAL..... 106

PLUG FAN OR BLANK-OFF PLATE INSTALLATION..... 107

SYSTEM OVERVIEW

SAFETY INFORMATION

The system design and installation must follow accepted industry practice as described in the ASHRAE Handbook, the National Electric Code, UL 60335-2-40, and other applicable standards. The equipment must be installed in accordance with regulations of authorities having jurisdiction and all applicable codes. Best practices shall be used to determine fan and control panel locations in the air handler. Installation and maintenance must be performed by qualified personnel familiar with the applicable codes and regulations, and experienced with this type of equipment.

Sheet metal parts, screws, mounting frames, clips, and other components may inherently have sharp edges which could cause injury; the installer must exercise caution.

For optimum safety and operation, the Q-PAC Fan must be installed at least one blade diameter away from upstream components or surfaces, and at least three feet (3 ft) from downstream components or surfaces.

For additional information and support, contact **Q-PAC Support** at **904-863-5300** or **support@q-pac.com**.



ELECTRICAL HAZARD

Turn off power and lock out all switches and devices before beginning installation or servicing.



QUALIFIED PERSONNEL

Installation and servicing should be performed by qualified personnel only. Appropriate personal protective equipment recommended.



ELECTRICAL CODES

This equipment shall be installed and operated per all applicable local codes.



ENCLOSURE RATING

To maintain the enclosure rating, installation shall utilize only those devices having the same or higher rating when installed to the manufacturer's specifications.



SUPERVISION

This appliance is not intended for use by persons (including children) with reduced physical, sensory or mental capabilities, or lack of experience and knowledge, unless they have been given supervision or instruction concerning use of the appliance by a person responsible for their safety. Children should be supervised to ensure that they do not play with the appliance.



REPLACEMENT PARTS

For proper motor protection and short circuit coordination, parts shall be replaced with identical parts (brand and model) or other factory-authorized parts.

RECEIVING AND HANDLING

The Q-PAC Fan, as referenced in this guide, is shipped knockdown—arriving as a collection of pallets for on-site assembly, or may be received as a singular assembly. Upon receipt, all pallets and/or crates should be carefully inspected for signs of damage and tampering. If any signs are found, ensure that the Bill of Lading (BOL) is annotated with details of the affected items and contact **Q-PAC Support** at **904-863-5300** or **support@q-pac.com** to have a claim opened. Q-PAC Support will then begin the process to replace all affected items.

Upon successful receipt of shipment, keep all pallets and/or crates together, unopened, until ready for assembly to ensure that no components are lost or damaged.

SHORT TERM STORAGE

Short term storage requirements shall apply for systems which will be placed in service within one year from the date of shipment. Improper storage may result in impaired functionality and component failure. Components shall be stored indoors, in a temperature-controlled environment, free from moisture, dirt, debris, and excessive vibration. Components shall be stored in their original packaging unless installed in an air handler meeting these storage conditions.

LONG TERM STORAGE

Long term storage requirements shall apply for systems which will be placed in service after one year but not more than two years from the date of shipment. For storage exceeding two years, contact Q-PAC for storage recommendations. Improper storage may result in impaired functionality and component failure. Components shall be stored indoors, in a temperature-controlled environment, free from moisture, dirt, debris, and excessive vibration. Components shall be stored in their original packaging unless installed in a cabinet meeting these storage conditions.

It is recommended that plug fans are not installed when in long term storage unless they can be operated for at least one hour each month. Plug fans should be stored flat, with the motor axis oriented vertically. Prior to start-up, plug fans shall have the yellow jumper connection removed between the 24V and Digital Input terminals of the motor. The motor shall be powered for at least one hour without this jumper. This is recommended to carry out a reformation of the internal capacitors before applying line voltage to the inverter. Refer to the Plug Fan Assembly Guides for more information on motor wiring.

FAN LAYOUT

The fan system consists of one or more Q-PAC fans - a variable-speed, multimotor plenum fan consisting of one to nine motors, the fan frame, the Fan Controller, and power/control harnesses. These fans can be connected to and controlled by Q-PAC's Control Panel or any external device through an analog or digital interface (Modbus).

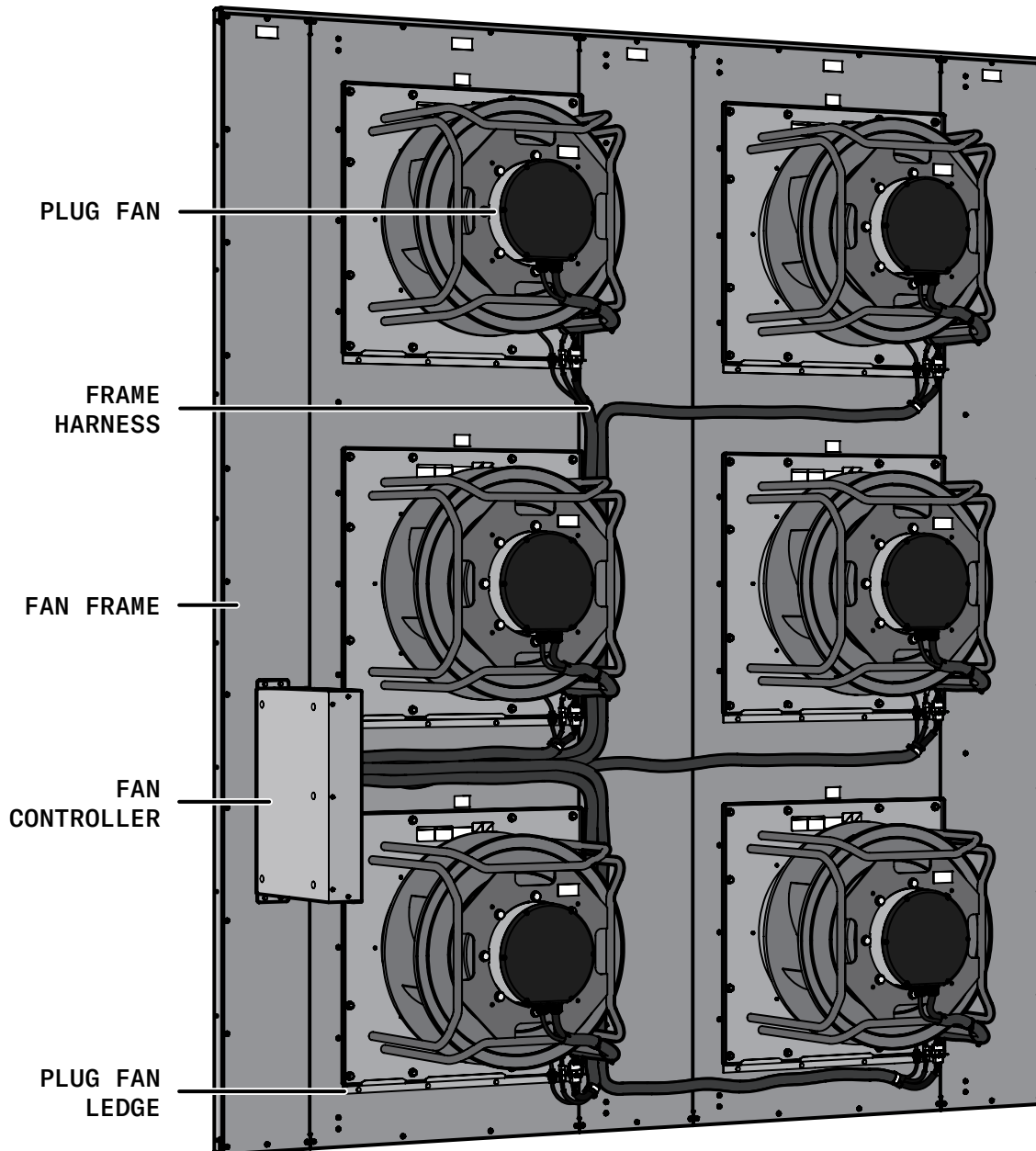

PLUG FAN

The Plug Fan is the interchangeable component consisting of a motorized impeller, inlet cone, motor harness, pressure tube, and supporting frame. The motor harness and pressure tube connect to a dedicated harness secured to the fan frame at the Plug Fan Ledge, which connects to the Fan Controller. The Q-PAC Fan uses plug fans from several manufacturers, given standardized connections by way of the motor harness.

FRAME HARNESS

Each Frame Harness consists of a power cable, control cable, and pressure tube joined within a wire loom. Each harness is manufactured at a specific length, unique to its corresponding route along the Fan Frame, from the Fan Controller to the Plug Fan Ledge. Each harness has a numeric label which corresponds to a set of plugs on the Fan Controller and a labeled route on the Fan Assembly Diagrams.

FAN FRAME

The Q-PAC Fan Frame consists of a set of interlocking galvanized steel panels assembled from left to right to form the pressure wall of the airstream and supporting frame for the Fan Controller, Plug Fans, and Frame Harnesses. Each frame panel consists of a bent structural channel and/or tab for mating with previous panels. The panels include a set of holes along the panel perimeter for securing the frame to the air handler and a set of holes along the channel for fastening successive panels together. Panels may also include a set of holes following the predetermined harness route and a set of a rivet nuts and a Plug Fan Ledge.

FAN CONTROLLER

The Fan Controller serves as the interface point for a Q-PAC fan, distributing power and control signals to each motor. It monitors the status of each motor and enables communication with external devices. The Fan Controller services up to nine motors with plug-and-play connections for power, control, and pressure monitoring, with an additional pressure port to monitor pressure immediately upstream of the Q-PAC fan.

PLUG FAN LEDGE

The Plug Fan Ledge serves as the connection point between each Plug Fan and its corresponding Frame Harness. The ledge secures the Frame Harness plugs to the Fan Frame when replacing a Plug Fan and serve as a support for the weight of the Plug Fan during this process.

FAN ACCESSORIES

CONTROL PANEL

The Control Panel is an optional interface for the Q-PAC Fan, installed outside of the airstream to control the Q-PAC Fan(s). Each panel can control up to four Q-PAC Fans (up to nine motors each), though each panel is sized for a set quantity of fans per the fan configuration.

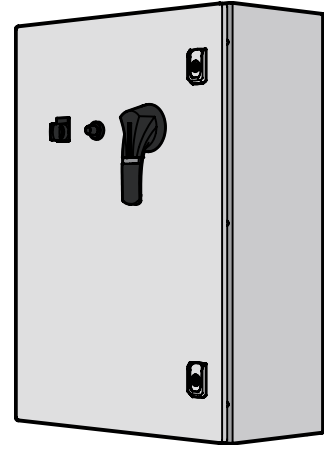

BASIC CONTROLS

The Basic Control Panel includes a dedicated set of fuses and terminal connections for each fan of the system and an analog connection for speed control. The panel also provides local control with a Hand/Off/Auto switch and disconnect.

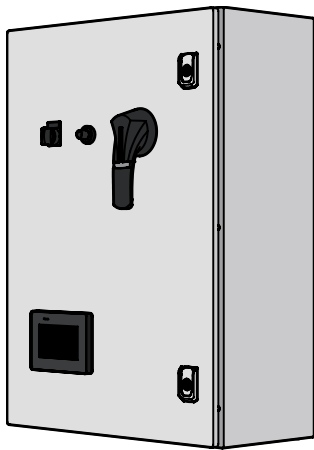

PREMIUM CONTROLS

The Premium Control Panel offers the same features of the Basic Control Panel with additional features of Interlock, Fireman Override, supplemental connections for field-supplied sensors and controls, and communication over BACnet MS/TP or BACnet/IP. In addition to the HOA switch, the panel includes a touchscreen HMI for system monitoring, alarms, and setting configuration.

PERIMETER ANGLES

The Perimeter Angle is a set of L-shaped structural galvanized steel components to be used if the air handler does not include a compatible flange to support the Q-PAC Fan. These angles are secured to flat, sturdy surfaces of the air handler, normal to the direction of airflow—generally the walls, floor, and ceiling of the air handler. Perimeter Angles are provided at the system level, supporting one or more Q-PAC Fans as needed. For information on how to install the Perimeter Angles, refer to the Q-PAC Fan Assembly Guide.

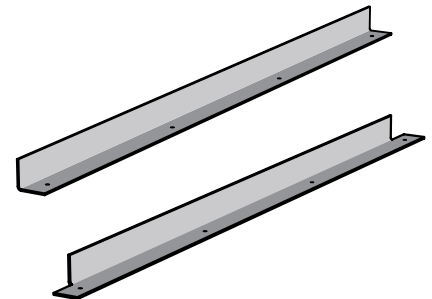

BACKDRAFT DAMPERS

Backdraft Dampers are a type of damper which are spring-loaded or gravity-operated. They automatically open as airflow passes through in one direction, but shut if that airflow stops or reverses. Backdraft Dampers may be used in critical applications to prevent backflow when a motor fails or if the fan is shut off. Q-PAC uses adjustable heavy duty counterweighted dampers.

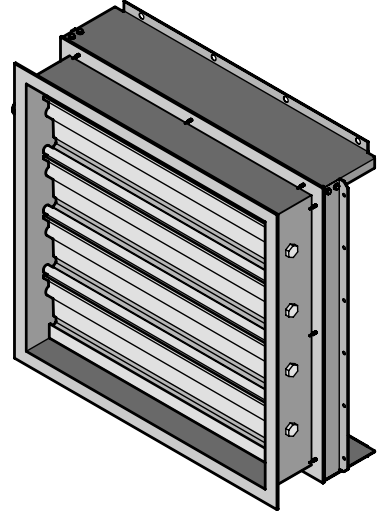

BLANK-OFF PLATE

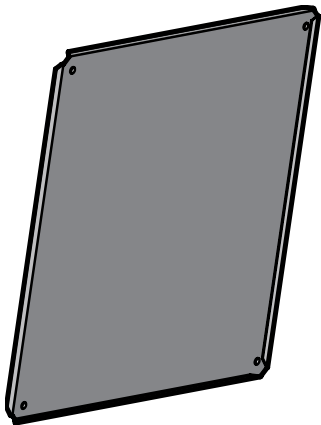

The Blank-Off Plate provides a manual method of backflow prevention in cases of motor failure. The Blank-Off Plate is installed in place of a Plug Fan to block airflow through that opening in the frame. This is useful when a Plug Fan will not be installed for an extended period of time. Blank-Off Plates may also be utilized in cases in which a fan was designed for a future airflow requirement, but a lower total airflow is required until that time.



Do not discard the Blank-Off Plate.

This plate is typically not used upon first installation; it is installed only when it is necessary to block off one motor location to limit backflow until that motor is replaced. Ensure the Blank-Off-Plate is set aside and accessible for maintenance.

NAMEPLATES

CONTROL PANEL

Q-PAC		
(904) 863-5300 SUPPORT@Q-PAC.COM 4010 DEERPARK BLVD ELKTON, FL 32033		
SO#:	9230	
TAG:	AHU-1	
MODEL:	1700224	
SERIAL#:	23H9999	
DATE OF MFG:	MM/DD/YYYY	
CONTROL PACKAGE:	PREMIUM	
POWER:	480V 3~ 60Hz	
SCCR:	100kA RMS SYM AT 460 V	
FLC:	55.70 A	
ENCLOSURE TYPE:	1	
ELECTRICAL DRAWING:	1234	

The Q-PAC Control Panel is UL Listed per **UL 508A**, signifying compliance with North American safety standards. This listing information is displayed on the front of the Control Panel. It is important that the Q-PAC Fan is operated in accordance with the given power ratings, plug fan selection, and other elements to maintain listing compliance.

For further information, contact **Q-PAC Support** at **904-863-5300** or **support@q-pac.com**.

FAN CONTROLLER

Q-PAC			RECOGNIZED COMPONENT	Q-PAC Fan Conforms to UL 60335-2-40:2022 Ed.4
(904) 863-5300 SUPPORT@Q-PAC.COM 4010 DEERPARK BLVD ELKTON, FL 32033			US Pat. Nos. 11.852.151 11.375.085	Fan Controller Certified to UL 60730-2-15:2019 Ed.3
SO#:	9230			
TAG:	7999 (K752) AHU-99-2 SF			
MODEL:	1-9-1-2-1-1700076			
SERIAL#:	23H9999			
MFG:	MM/DD/YYYY			
MODBUS ADDR:	017			
POWER:	480V 3~ 60Hz			
SCCR:	10kA RMS SYM AT 600 V MAX			
MTR FLA:	7.86 A			
MCA:	72.70 A			
MOCP:	80.00 A			
USE 15 AMP CLASS CC 600V FUSES				

The Q-PAC Fan is an ETL Recognized Component per UL 60335-2-40, CSA C22.2 and UL 60730-2-15. This listing information is displayed on the cover plate of the Fan Controller. It is important that Q-PAC Fan is operated in accordance with the given power ratings, plug fan selection, and other elements to maintain compliance.

For further information, contact **Q-PAC Support** at **904-863-5300** or **support@q-pac.com**.

Q-PAC FAN MODEL NUMBER

EXAMPLE MODEL NUMBER :

1 - 9 - 1 - 2 - 1 - 1700076
A B C D E F

BREAKDOWN :

A PRODUCT CLASS

Internal tracking of product segmentation.

B MOTOR QTY

Number of motors used in the fan.

1 - 9

C MOTOR LAYOUT

Arrangement of motors within the fan, based on motor quantity and aspect ratio.

1 - 22

D INPUT VOLTAGE

Nominal voltage rating of the fan.

1 = 208V 3~ 60Hz

2 = 480V 3~ 60Hz

E BACKFLOW DEVICE

Method of backflow prevention in case of motor failure.

1 = Blank-off Plate

2 = Backdraft Dampers

F PLUG FAN MODEL

Q-PAC model number for the motor and impeller assembly used in the fan.
See **Page 23** for full list of model numbers.

CONTROL PANEL LAYOUT

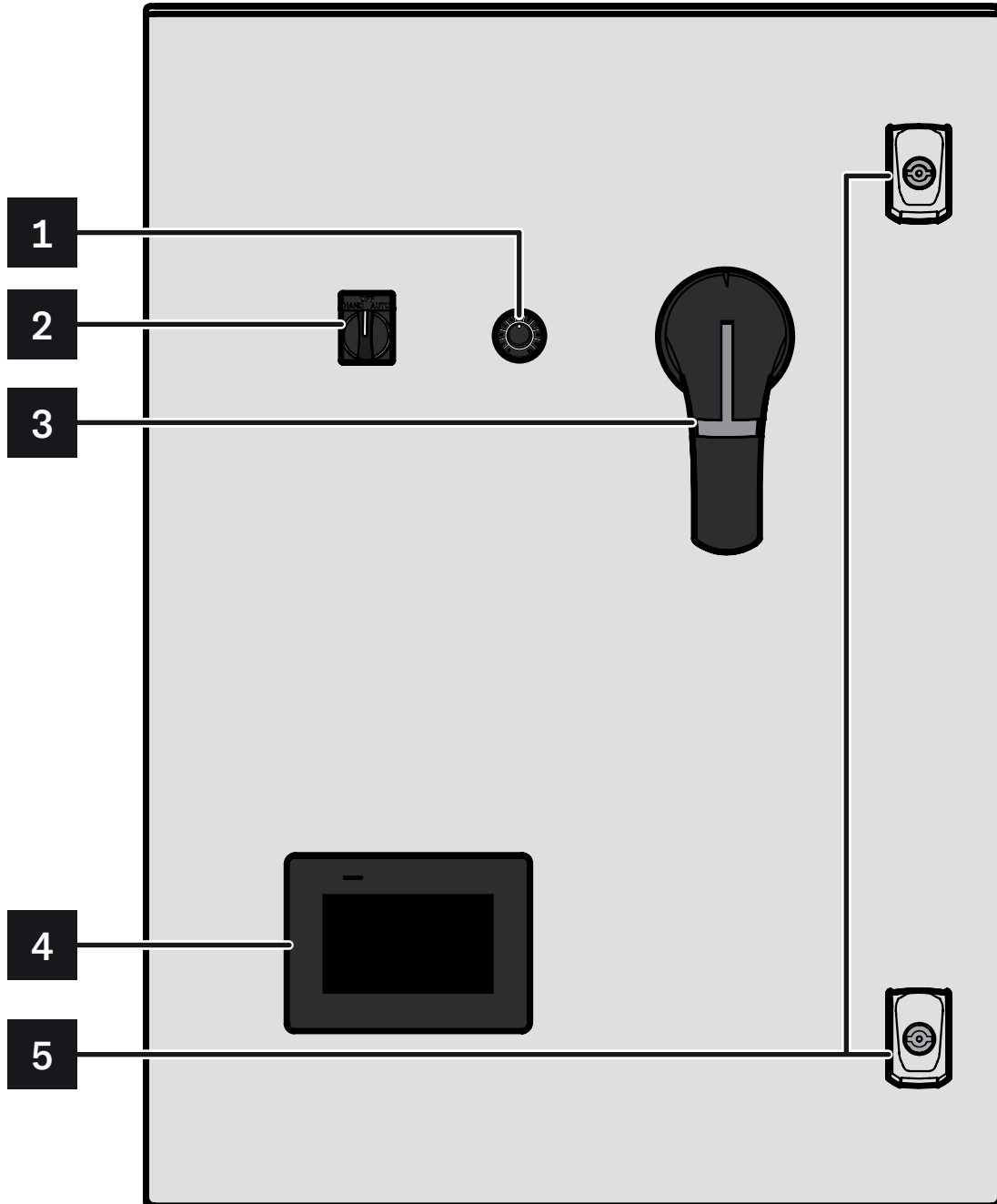

1

POTENTIOMETER

Variable resistor with a rotating dial to manually adjust speed when in HAND MODE.



Use caution when operating the system in HAND MODE. Improper use may result in damage to the upstream or downstream components or ductwork.

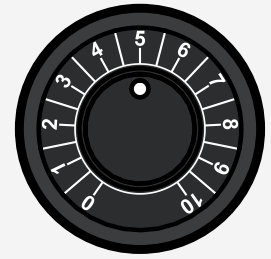

2

HAND / OFF / AUTO (HOA) SWITCH

HAND Bypass the controller and use the potentiometer to control motor speed linearly. Overrides Interlock, Delay on Start Timer, Relay 1 delays, and Fireman Override. Will not override the Safety Circuit.

OFF System is turned off. Motors will not operate.

AUTO System speed is determined by the controller.



3

DISCONNECT HANDLE

Main electrical shutoff of the system for service or maintenance.

4

HMI

Touchscreen interface for the controller.

5

LOCKS

Control Panel door locks, accessible via flathead tool.

FAN CONTROLLER LAYOUT

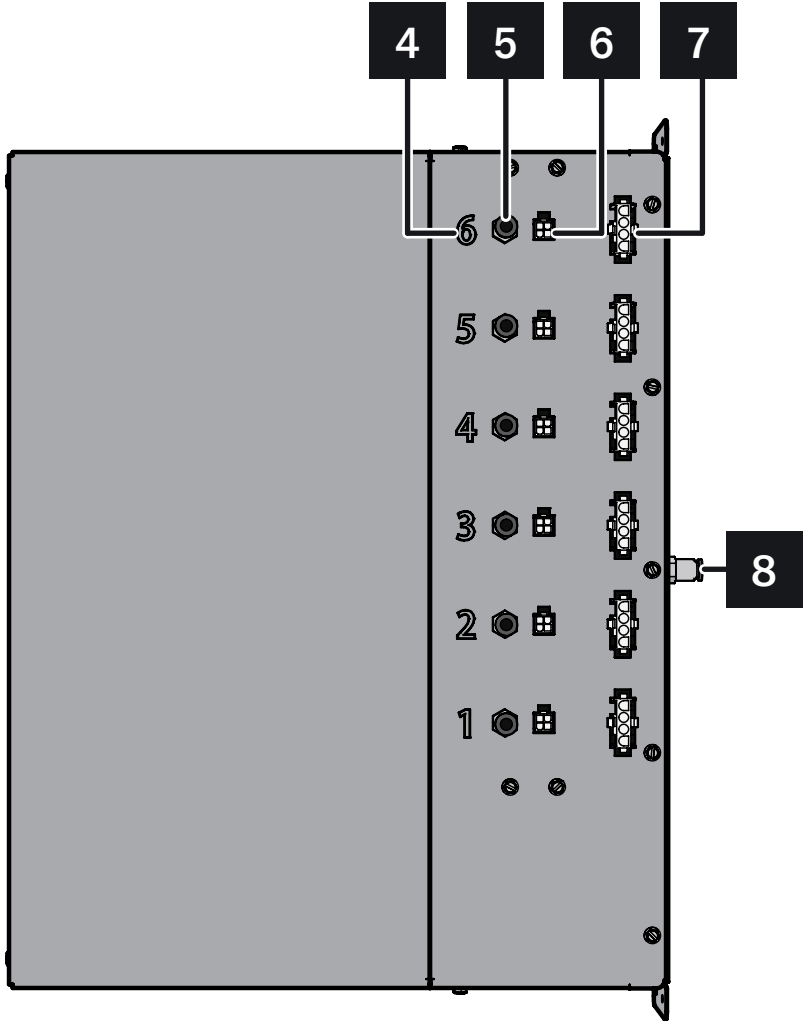
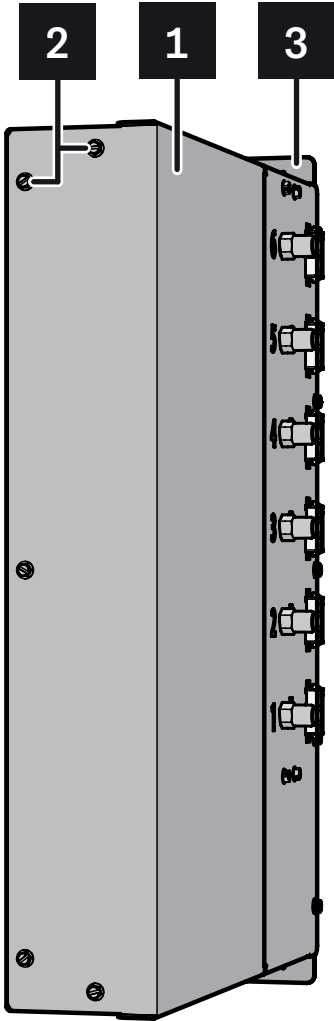

1

FRONT COVER

Removable panel permitting access to the **Q-PAC Fan Controller Board** for field wiring.

2

FRONT COVER SCREWS

Five (5) #8-32 hex head screws with a slotted drive. These screws must be unfastened to remove the **Front Cover**.

3

MOUNTING BRACKETS

Two flanged mounts to secure the Fan Controller to the frame of the Q-PAC Fan. See the **Q-PAC Fan Assembly Guide** for more information.

4

HARNESS INDICATOR

Etched labels on the **Fan Controller** side panel serving as a guide when connecting the harnesses between the Fan Controller and each motor.

5

LOW PRESSURE NOZZLE

Push fitting for the pressure tubing of each harness, corresponding with the etched **Harness Indicator**.

6

CONTROL CONNECTION

Female control receptacle of each harness, corresponding with the etched **Harness Indicator**.

7

POWER CONNECTION

Female power receptacle of each harness, corresponding with the etched **Harness Indicator**.

8

HIGH PRESSURE NOZZLE

Nozzle designed to pass through a cutout in the fan frame to measure pressure immediately upstream of the Q-PAC Fan.

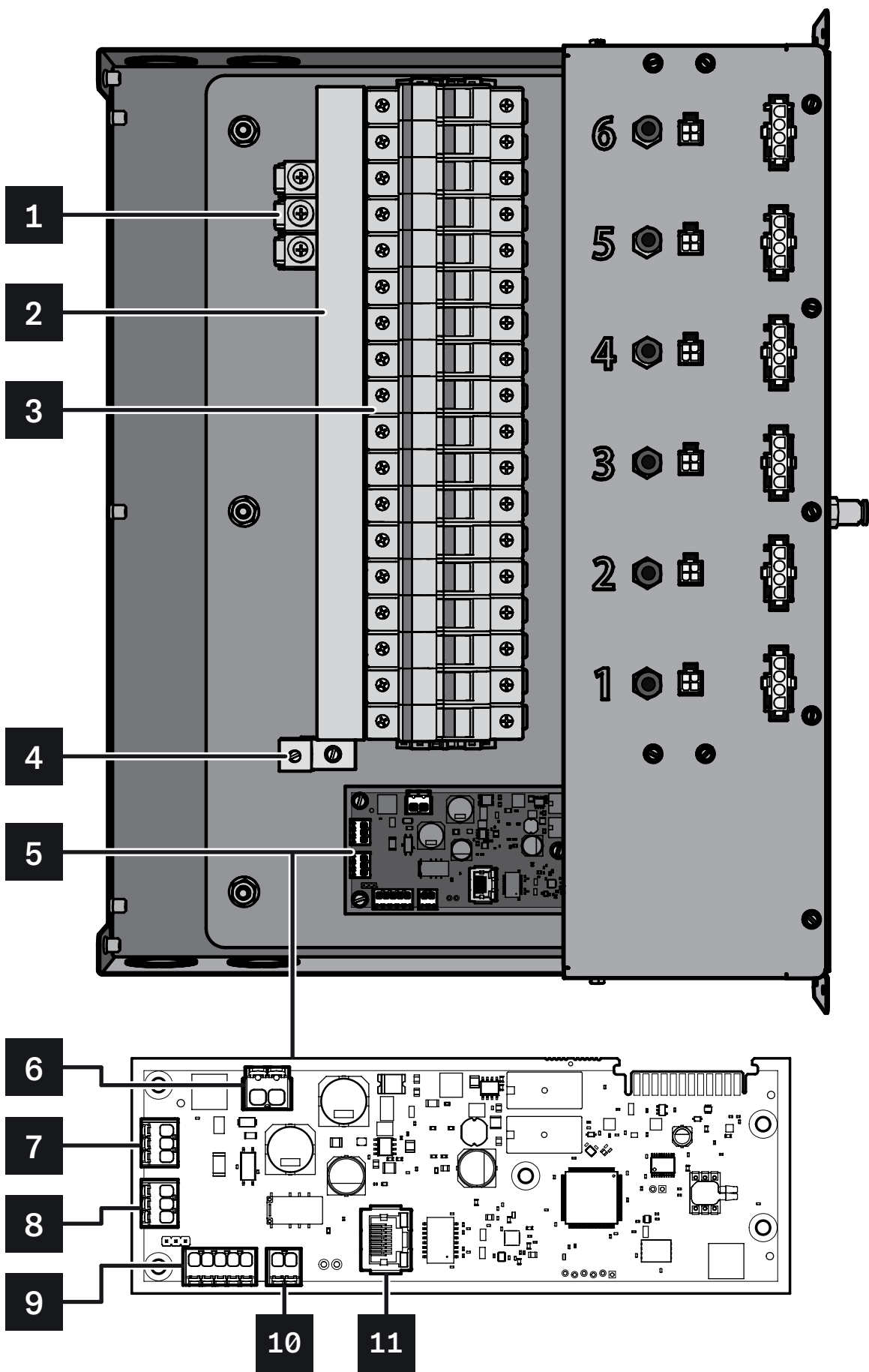

1**INPUT POWER CONNECTOR (PI)**

Input for power to be distributed to the motors of the Q-PAC Fan. Voltage either 208VAC or 480VAC and current up to 96A. See Nameplate for actual values.

2**POWER BUS BAR**

Distributes input power to the fuses.

3**FUSE HOLDERS**

Holds class CC fuses to protect each phase of the power lines to each motor.

4**GROUND CONNECTOR (GND)**

Earth ground connection.

5**FAN CONTROLLER BOARD**

Q-PAC Fan PCB containing the Control Panel Connectors (CN1 and CN2), Low Voltage Power Supply Input (CN3), Modbus Communication Ports (CN4 and CN5), and Ethernet Port (RJ-45).

6**LOW VOLTAGE INPUT POWER (CN3)**

Provide 24V AC/DC 500mA with a Class 2 supply.

7**COMMUNICATIONS PORT (CN5)**

RS-485 serial data connection.

8**COMMUNICATIONS PORT (CN4)**

RS-485 serial data connection.

9**CONNECTOR TO CONTROL PANEL: ANALOG OUT (CN1)**

Fan Controller output connector. See **Page 30** for signal descriptions.

10**CONNECTOR TO CONTROL PANEL: ANALOG IN (CN2)**

Fan Controller input connector. See **Page 30** for signal descriptions.

11**ETHERNET PORT (RJ-45)**

Reserved for future usage.

POWER HARMONICS

The term “harmonics” refers to electrical noise. Harmonics result from nonlinear loads converting AC line voltage to DC because of switching devices like variable frequency drives (VFDs), computer power supplies and energy-efficient lighting, which introduce noise at different frequencies.

Harmonics becomes a problem when the noise is strong, or when noise from multiple devices superimposes on a shared transmission line.

Harmonics are often attributed to cumulative noise from several separate devices. Therefore managing harmonics is a joint responsibility involving end-users, system owners or operators, and OEMs. End-users limit what equipment is on which circuit, or change operating set points. System owners and operators modify system characteristics so that voltage distortion levels are acceptable if needed. OEMs, like Q-PAC, ensure their equipment is compliant with applicable conducted emission regulations within the jurisdiction.

For proper operation of an electrical system, harmonic resonance and harmonic distortion should be minimized. Building electrical distribution systems with a large number of nonlinear loads may experience harmonic resonance - the superimposing of noise from multiple devices. This causes harmonic distortion current which can accumulate at a major supply transformer causing harmonic voltage distortion. Common symptoms of issues experiencing harmonics issues include:

- Nuisance tripping of circuit breaker and fuses
- Overheating of motors, cables, or electrical components
- Electromagnetic Interference (EMI) on control and data signals
- Increased installation and utility cost
- Reduced power output from supply transformers

IEEE-519 recommends harmonic measurements and limits. For Q-PAC installations ($V < 1$ kV), the recommendation is to stay below 7.5% individual and 12% total harmonic distortion. This is for the 99th percentile weekly short time, measured at the point of common connection (PCC).

Q-PAC Fans include different motors, with different options for harmonics depending on the original motor manufacturer. Support information for specific models can be found on **Page 23**.

For further information or questions about potential harmonics issues with your system, contact **Q-PAC Support** at **904-863-5300** or **support@q-pac.com**.

ZIEHL - ABEGG MOTORS

ZIEHL-ABEGG recommends the following motors receive adjusted programming when used with a passive filter for harmonics. ZIEHL-ABEGG's active harmonic filter may be used without reprogramming the motors. The table below lists the reference model numbers for Q-PAC and ZIEHL-ABEGG.

Contact **Q-PAC Support** at **904-863-5300** or **support@q-pac.com** for assistance reprogramming these motors for use with harmonic filters.

Q-PAC	ZIEHL - ABEGG	Q-PAC	ZIEHL - ABEGG	Q-PAC	ZIEHL - ABEGG
1700069	116169	1700074	116167	1700079	116178
1700070	116552	1700075	116174	1700080	116182
1700071	116553	1700076	116175	1700081	116181
1700072	117050	1700077	116176	1700082	116165
1700073	116617	1700078	116177	1700083	117885

ROSENBERG MOTORS

Rosenberg motors do not require reprogramming, but are recommended for use with an active filter, if necessary for the application.

Q-PAC	ROSENBERG
1700090	N88-40327
1700091	N88-45316
1700519	N88-40303
1700523	N88-50322
1700526	N88-35831

EBM - PAPST MOTORS

EBM's RadiPac and RadiCal series of EC centrifugal fans have an integrated 3-phase active PFC solution that enables their motors to achieve a power factor of 0.99 and a THDI value of less than 5 percent. This applies to model 1700143.

Q-PAC	EBM - PAPST
1700141	EG1R240-450-282
1700143	EG1R480-450-282

AIRFLOW MEASUREMENT

Q-PAC Fans calculate airflow based upon the pressure differential across each motorized impeller - the static pressure immediately in front of the inlet cone and the pressure at the narrowest point of the inlet cone. This technique is based on the Bernoulli and Continuity equations, which provide for the calculation of airflow through a converging nozzle based upon measurement of the static pressure across the nozzle.

Q-PAC Fans measure this differential pressure with a dedicated pressure transducer for each motorized impeller, reporting the measured value back to the controller to calculate airflow through that impeller. This value can be accessed directly through the Control Panel HMI (**Page 88**) or as a 0 - 10 VDC analog output (**Page 36**).

This 0 - 10V output is linearly scaled between 0 and the maximum airflow of the motorized impeller of the Q-PAC fan. For example, a 5V signal translates to 50% of the maximum airflow of the fan. The equation for this model is given as:

$$\text{Airflow} = \frac{V}{10} \times N \times q_{\max}$$

Where,

V	=	0 - 10V signal
N	=	Number of motors
q_{max}	=	Maximum airflow of an individual plug fan

For further information, contact **Q-PAC Support** at **904-863-5300** or **support@q-pac.com**.

AIRFLOW REFERENCE VALUES

The following tables give the maximum airflow, in CFM, for each plug fan model. These values are multiplied by the measured voltage across AO1+ (**Page 30**) and the number of motors in the fan to calculate the fan's total airflow.

MODEL	MAX AIRFLOW	MODEL	MAX AIRFLOW	MODEL	MAX AIRFLOW
1700032	3950	1700042	3400	1700051	7500
1700033	9400	1700043	2900	1700052	7800
1700034	3900	1700044	4400	1700053	8900
1700036	6800	1700045	4800	1700054	9200
1700037	7900	1700046	3600	1700055	10400
1700038	4200	1700047	5000	1700056	5400
1700039	4700	1700048	5600	1700057	4200
1700040	3400	1700049	6250	1700058	4200
1700041	5300	1700050	6600	1700059	9800

MODEL	MAX AIRFLOW	MODEL	MAX AIRFLOW	MODEL	MAX AIRFLOW
1700060	4300	1700072	6800	1700082	4200
1700061	10200	1700073	4200	1700083	5500
1700062	9700	1700074	3600	1700100	7000
1700064	9200	1700075	5000	1700101	8900
1700066	5500	1700076	6250	1700140	9190
1700067	13400	1700077	6600	1700141	9100
1700068	18900	1700078	7500	1700143	9710
1700069	4800	1700079	9000	1700515	3300
1700070	3400	1700080	9200	1700519	5300
1700071	3950	1700081	10400		

The following models support multiple voltages, though maximum airflow varies with the input voltage.



The Q-PAC Fan should only be operated within its rated voltage range. Please contact **Q-PAC Support** at 904-863-5300 or support@q-pac.com if the fan must operate at a different voltage.

MODEL	INPUT POWER	MAX AIRFLOW	INPUT POWER	MAX AIRFLOW
1700090	200-240V 3~ 60Hz	5400	440-480V 3~ 60Hz	5900
1700091	200-240V 3~ 60Hz	6750	440-480V 3~ 60Hz	7100
1700523	200-240V 3~ 60Hz	8400	440-480V 3~ 60Hz	9800
1700526	200-240V 3~ 60Hz	4300	440-480V 3~ 60Hz	4900

**WIRING THE
Q - PAC FAN**

WIRING PREPARATION



Wiring the Q-PAC Fan should be completed only after the fan has been fully assembled and installed in the air handler. Refer to the **Q-PAC Fan Assembly Guide**.

Wiring the fan consists of three main steps:

1. Removing the Q-PAC Fan Controller Cover Plate
2. Removing the knock-out port(s) for conduit installation
3. Wiring the Fan Controller Board terminals

REMOVING THE FAN CONTROLLER COVER

To remove the Fan Controller Cover Plate,

1. Remove the five (5) #8-32 hex head screws using either a 1/4" hex head drive or a standard or slotted (flathead) screwdriver.
2. Slide the Cover Plate forward, away from the Fan Frame, and out, away from the Fan Controller to access the internal fuses and terminals.

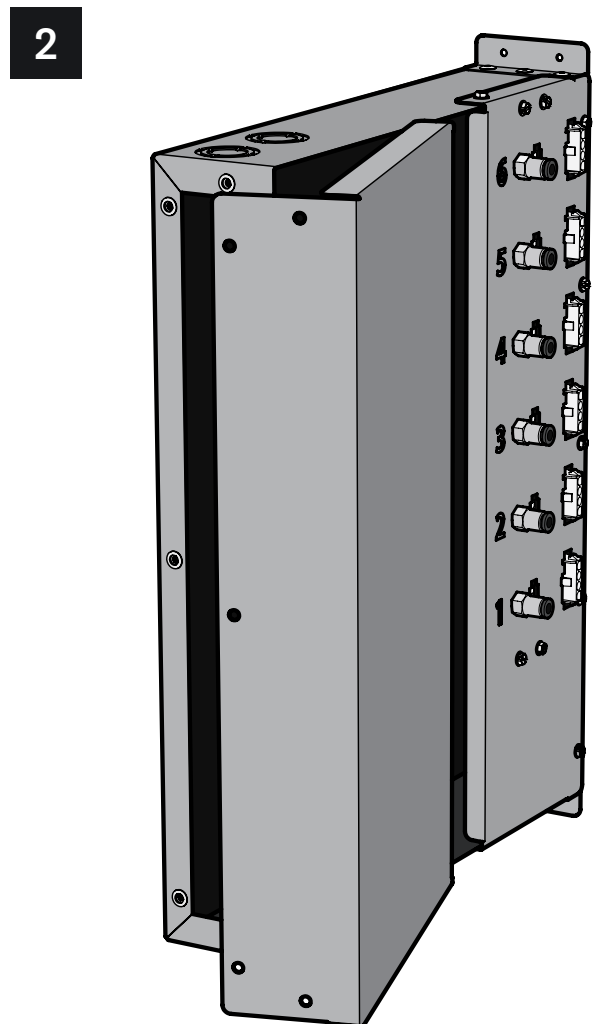
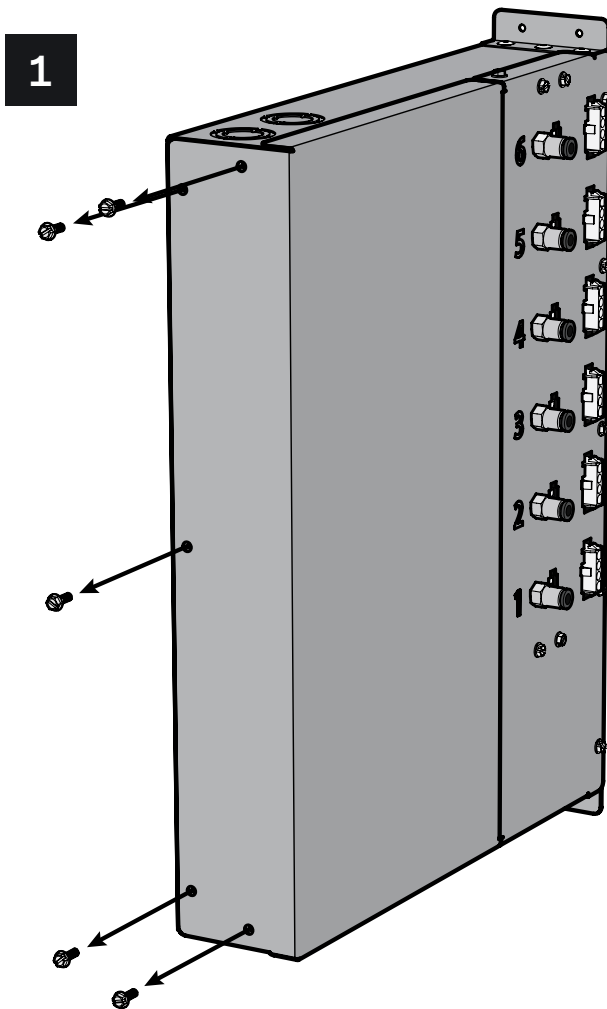

REMOVING THE FAN CONTROLLER KNOCKOUT PORTS

The Fan Controller includes four knockout ports, two each at the top and bottom of the unit. Each port features three (3) size options to suit standard trade sizes of 1/2 in, 3/4 in, and 1 in.

1/2 in AND 1 in KNOCKOUTS

1. Using a standard or slotted (flathead) screwdriver and mallet (or similar tools), position the tip of the screwdriver just inside the edge of the knockout, near one of the tabs.
2. Tap the screwdriver with the mallet to push the knockout away from the shell of the Fan Controller.
3. Repeat until the knockout is free, using a set of pliers or similar tools as necessary to fully remove the knockout.

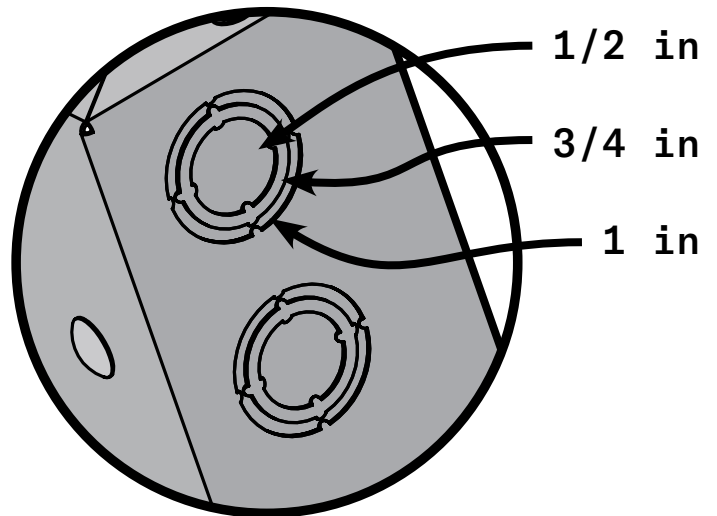

3/4 in KNOCKOUTS

1. Using a standard or slotted (flathead) screwdriver, pry the center ring of the knockout forward, away from the shell, at opposing sides.
2. Using a set of pliers or similar tools, bent these tabs back and forth until the connection breaks free.

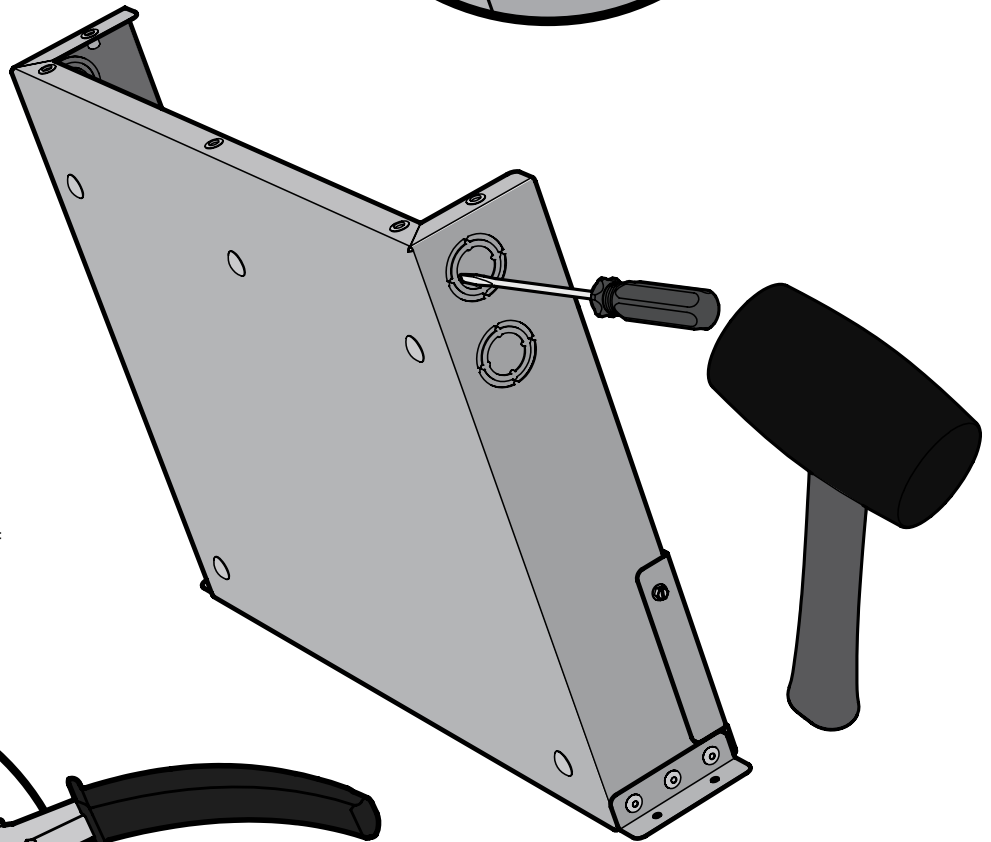

Use caution when removing the knock-outs to ensure that internal components of the **Fan Controller** are free from damage.

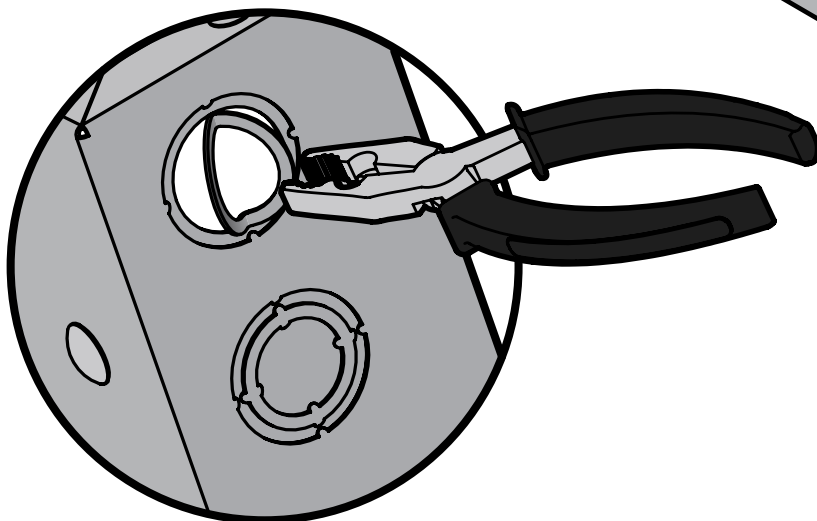

FAN WIRING

FAN CONTROLLER BOARD

CN2: ANALOG IN

1	AI1+	0-10V signal proportional to the motor speed.
2	AI1-	0V reference for AI1+ .

CN1: ANALOG OUT

3	K1A	Normally closed (unpowered) contact of the alarm relay. When the controller receives power, the contact opens to indicate the absence of an alarm. If a fault occurs the contact will close again.
4	K1C	Common contact of the alarm relay. When a fault is present in the unit, this pin is connected to Alarm relay NC K1A and disconnected from Alarm relay NO K1B .
5	K1B	Normally open (unpowered) contact of the alarm relay. When the controller receives power, this contact closes to indicate the absence of an alarm. If a fault occurs the contact will open again.
6	A01+	0-10V signal proportional to the calculated airflow.
7	A01-	0V reference for A01+ .

CN4: COMMUNICATION

8	GND	Ground/Shield/Common
9	-	RS485 negative data terminal.
10	+	RS485 positive data terminal.

CN5: COMMUNICATION

11	GND	Ground/Shield/Common
12	-	RS485 negative data terminal.
13	+	RS485 positive data terminal.

CN3: INPUT POWER

14	0V	Connection to power supply, neutral for AC or ground DC.
15	24V	Connection to supply voltage, 24V AC/DC-500mA.

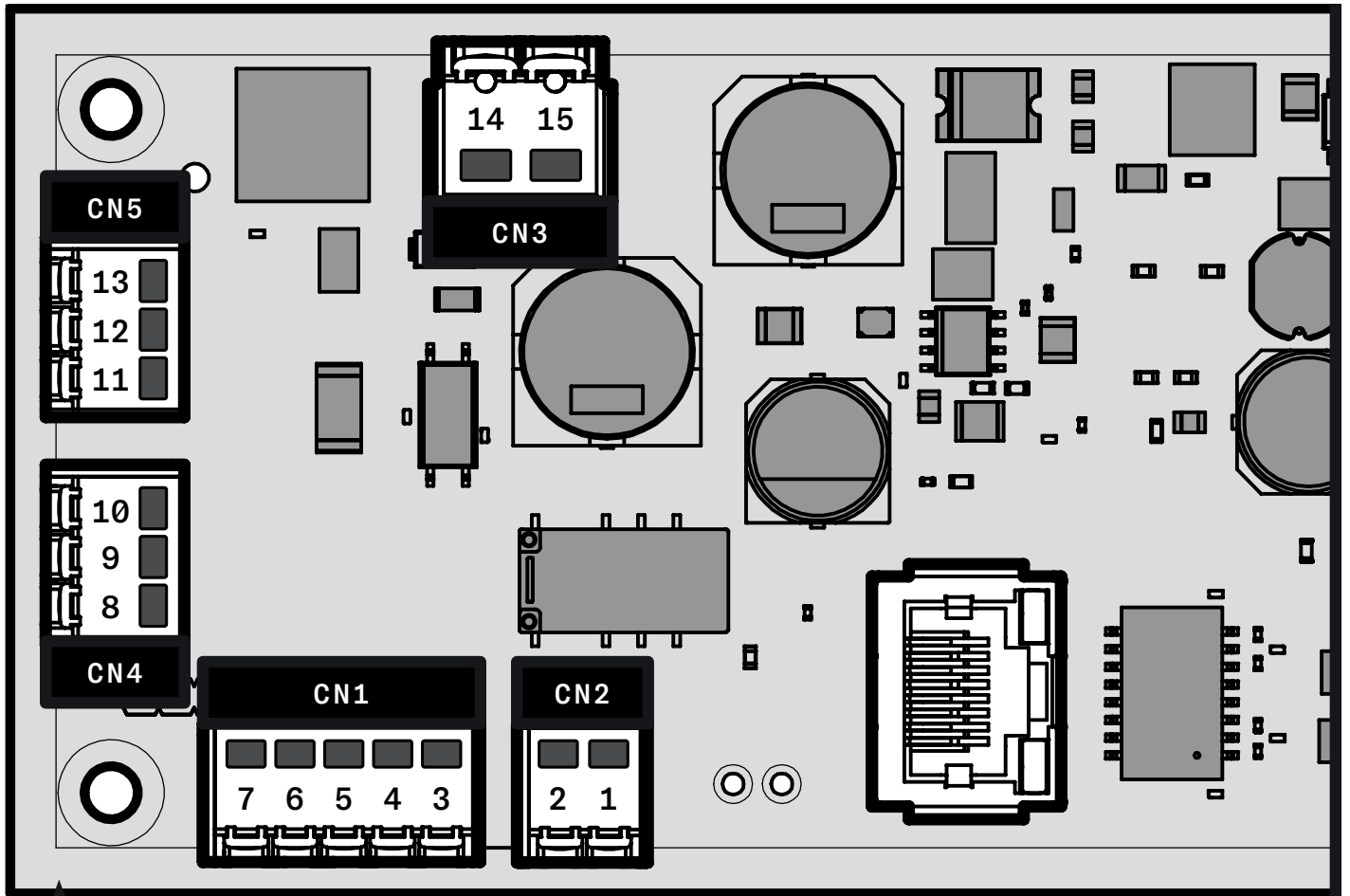

FAN CONTROLLER BOARD

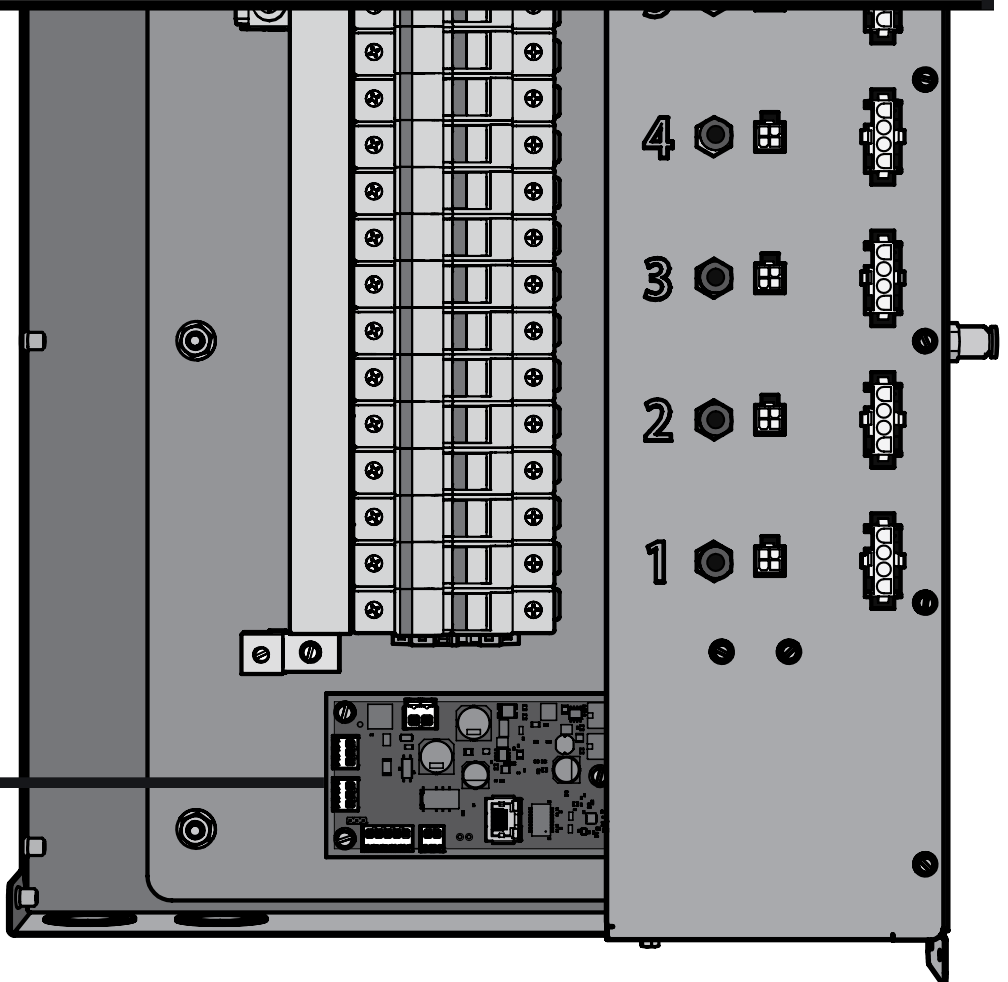

FAN CONTROLLER

SINGLE FAN

The Control Panel has a dedicated set of terminals for power and controls for each Q-PAC Fan. This means that, for multiple fans, there is no need to daisy chain controls between fans. For systems of only one fan, there will be no connection present for CN5 terminals of the Fan Controller. This also applies to the last fan in a system of multiple fans. The wiring of the single and multiple-fan conditions are given below and in the reference Wiring Guides provided with the order.

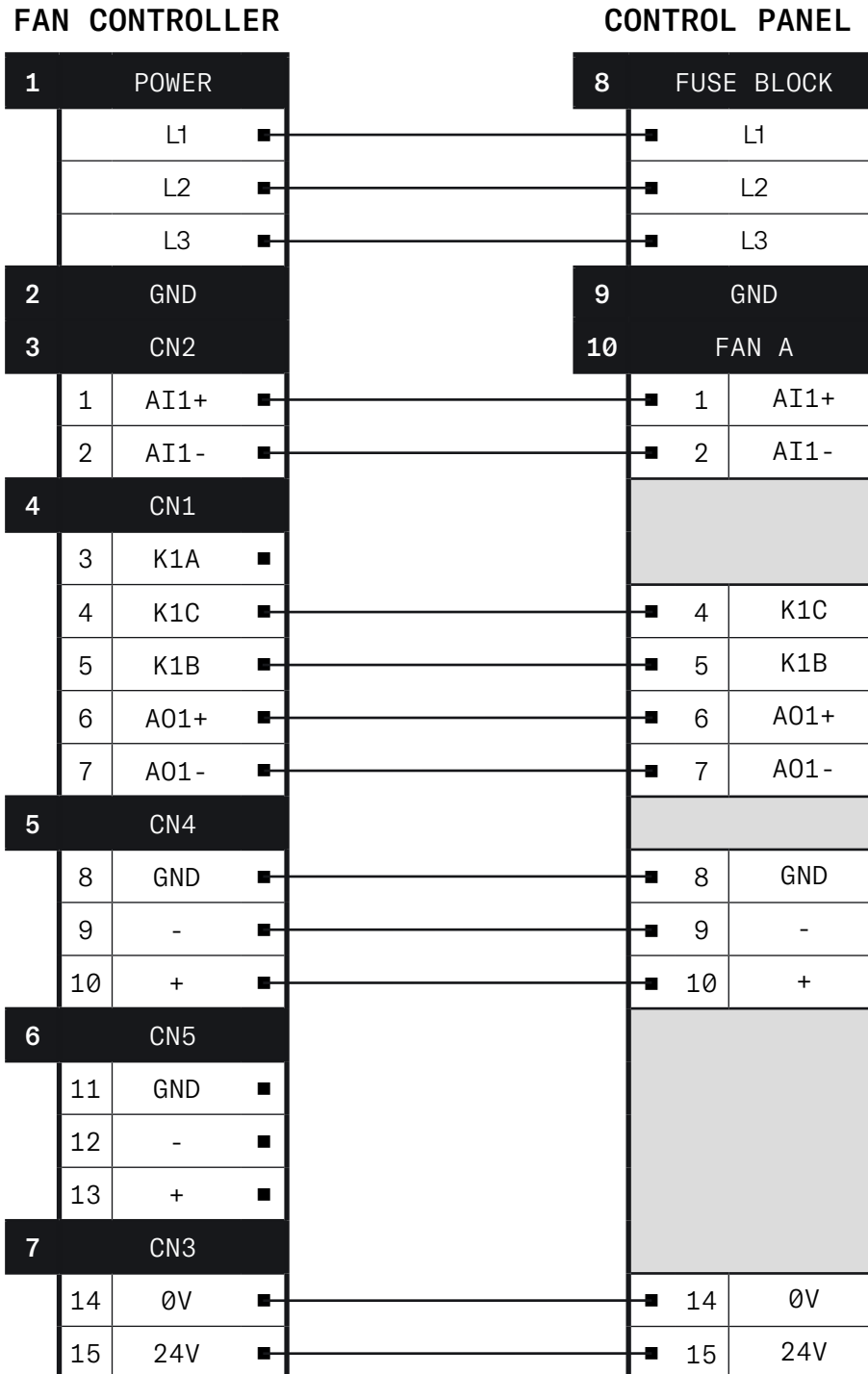

MULTIPLE FANS

For systems of multiple Q-PAC Fans, the last fan of the system will have no connection to the **CN5** terminals of the Fan Controller. The last fan will follow **Wiring Scheme 2** while all other fans (first and intermediate) will follow **Wiring Scheme 1**. For example, in a system of 2 Q-PAC Fans, Fan A will follow **Wiring Scheme 1** and Fan B will follow **Wiring Scheme 2**. In a system of four fans, Fans A, B, and C will follow **Wiring Scheme 1** and Fan D will follow **Wiring Scheme 2**.

WIRING SCHEME 1

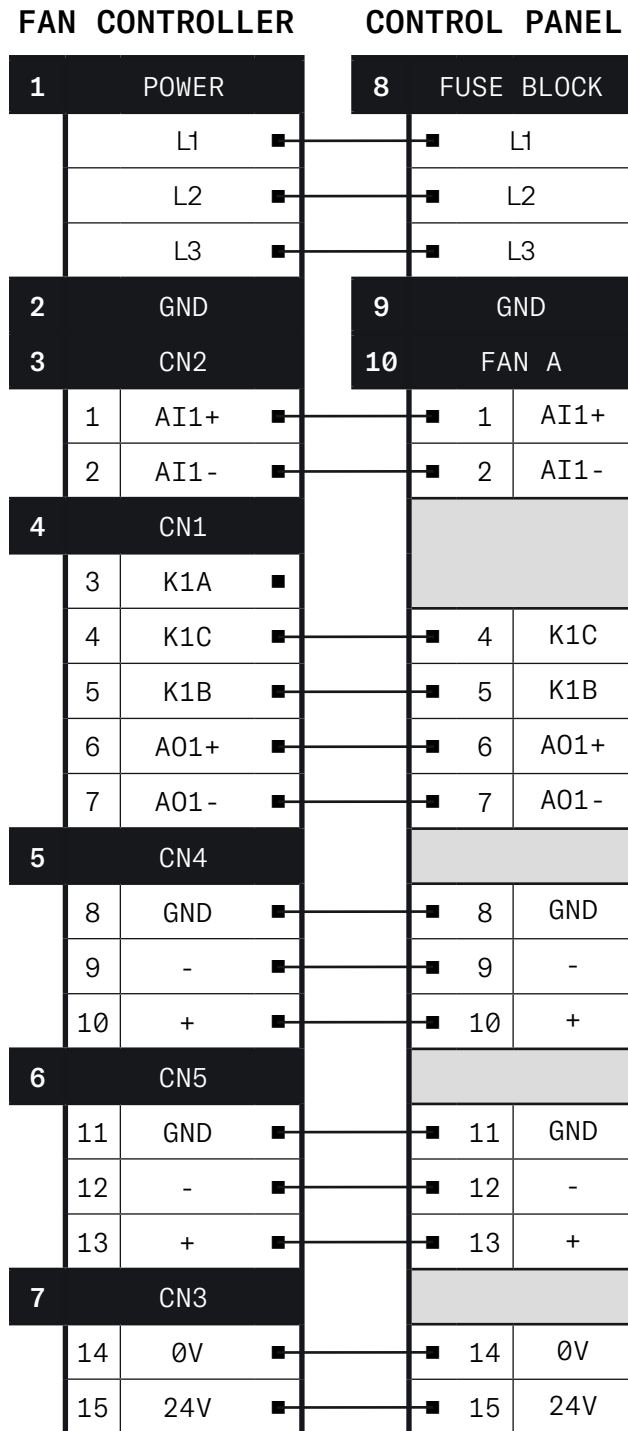

WIRING SCHEME 2

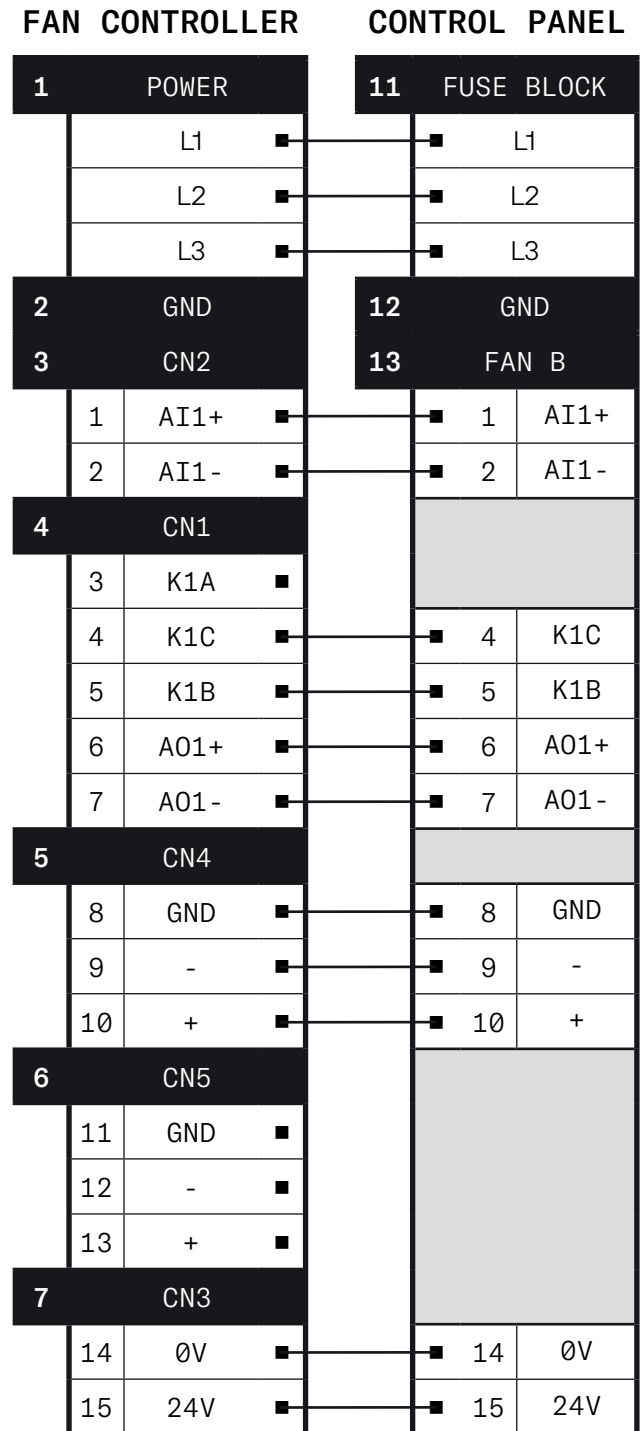

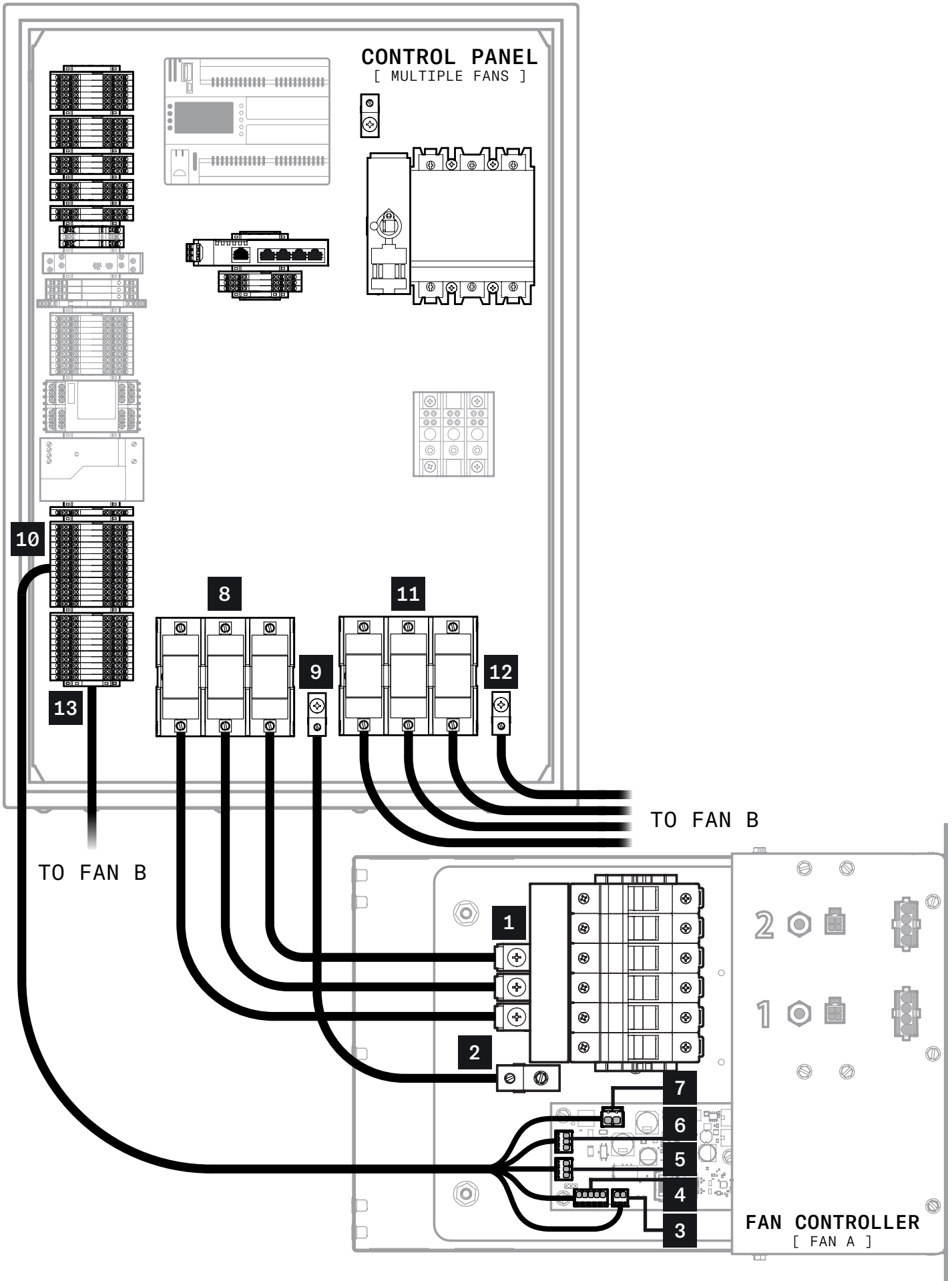

CONTROL PANEL WIRING

The Control Panel is designed as an external connection point for the fan system back to the BMS/BAS. Terminals listed as required represent the minimum connections to operate the system, ensuring power, analog control, and safety.

1 TB 1				REQUIRED
AI1	Analog Input	Speed control, 0 - 10VDC		Yes
AI2	Analog Input	Static pressure sensor, 0 - 10VDC		
A01	Analog Output	Calculated airflow, 0 - 10VDC		
COM	Common	Common for analog signals		Yes
2 TB 2				
24VDC	Digital Output	Output for Digital Input controls (DI1 - DI4), 24VDC		Yes
DI1	Digital Input	Safety Circuit		Yes
DI2	Digital Input	Start/Stop		Yes
DI3	Digital Input	Interlock, see Page 76 to enable		
DI4	Digital Input	Fireman Override, see Page 74 to enable		
3 TB 3				
R01A	Relay Output	Ready/Operational (RO1C-R01A connected)		
R01B	Relay Output	Not ready/Operational (RO1C-R01B connected)		
R01C	Relay Output	Max 250VAC/3A, 24VDC/2A		
4 TB 4				
R02A	Relay Output	Running (RO2C-R02A connected)		
R02B	Relay Output	Not running (RO2C-R02B connected)		
R02C	Relay Output	Max 250VAC/3A, 24VDC/2A		
5 TB 5				
R03C	Relay Output	Normally open (unpowered) contact of the alarm relay. When the panel receives power, the contact closes to indicate the absence of an alarm. If a fault occurs, the contact will open again.		
R03B				
6 TB 6				
+24	Supplemental power supply for field-supplied sensors and controls, 24VDC output, 0.75A maximum			
-24				
7 CONTROLLER				
RS485+	Differential pair signal for BACnet MS/TP connections			
RS485-				
GND	Signal ground for BACnet MS/TP connections			
NETWORK SWITCH	Ethernet port for BACnet/IP connections			
8 POWER				
L1	3 Phase 208V or 480V input voltage for motors			Yes
L2	3 Phase 208V or 480V input voltage for motors			Yes
L3	3 Phase 208V or 480V input voltage for motors			Yes
9 GND				Yes

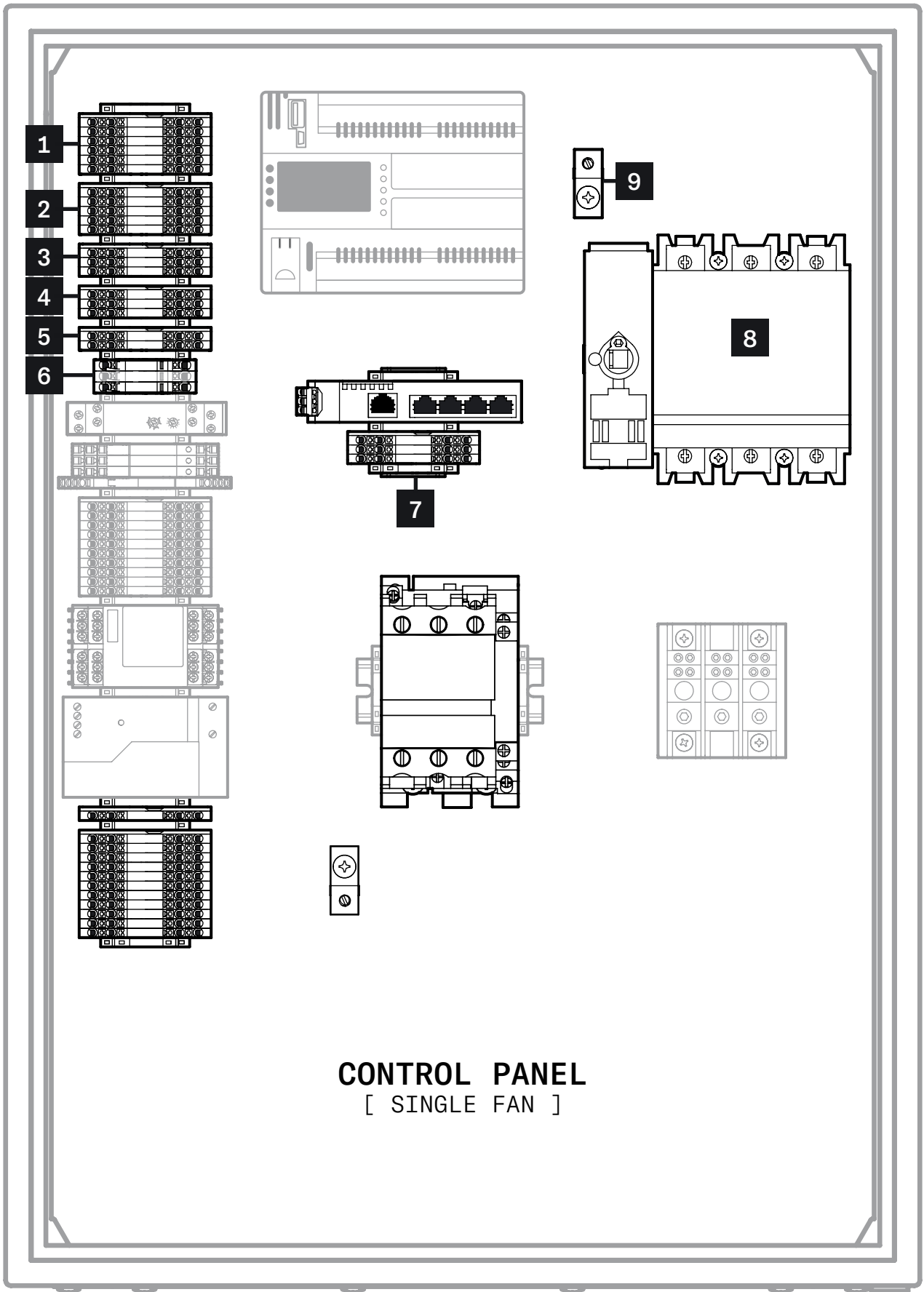

CONTROL PANEL
[SINGLE FAN]

WIRE SIZING

When connecting the Q-PAC Fan to the Control Panel or other system components, it is recommended to use the following wire sizes:

CONTROL PANEL

208/480 VAC INPUT POWER

Conductor size – determined by NEC – and Control Panel FLC, as listed on the Control Panel Nameplate (**Page 14**).

CONTROLS

- 24 VDC (+/- 10%) 500 mA OR 24 VAC (+/- 10%) 500 mA to **TB2 24V**
- 0-10 VDC 1 mA to **TB1 AI1, AI2, and AO1**

FAN CONTROLLER

208/480 VAC INPUT POWER

Conductor size determined by NEC and Fan Controller MCA, as listed on the Fan Controller Nameplate (**Page 14**).

CONTROLS

- Min 24 AWG (stranded CU) to **CN1, CN2, and CN3**
- Min 24 AWG (stranded CU) shielded twisted pair to **CN4 and CN5**

ELECTRICAL CHARACTERISTICS

The Fan Controller has two separate circuits: low voltage and high voltage. The low voltage circuit supplies power to the internal boards of the Fan Controller while the high voltage circuit supplies power to the motors of the Q-PAC Fan. The electrical characteristics of each are given below:

LOW VOLTAGE CIRCUIT

INPUT POWER (CN3)

NOMINAL INPUT VOLTAGE	24VDC or 24VAC
MAXIMUM INPUT VOLTAGE ¹	63VDC or 44VAC
FLA	500mA
MOCP	1A

¹ When a voltage higher than 40VDC or 28.3VAC is applied through CN3, the overvoltage protection circuit disconnects the input of the power supply block to prevent damage. The circuit automatically resets when the protection fuse returns to its operation temperature range.

ANALOG INPUTS (CN2)

SPEED MODULATION INPUT - VOLTAGE RANGE	0 - 10V
SPEED MODULATION INPUT - INPUT RESISTANCE	100Kohm
SPEED MODULATION INPUT - MAXIMUM VOLTAGE	40VDC

ANALOG OUTPUTS (CN1)

AIRFLOW ANALOG OUTPUT - VOLTAGE RANGE	0 - 10V
---------------------------------------	---------

RELAY OUTPUTS (CN1)

ALARM RELAY CONTACTS RATED LOAD ²	0.5A @ 125VAC or 2A @ 30VDC
MAXIMUM OPERATING VOLTAGE	125VAC or 125 VDC
MAXIMUM SWITCHING CAPACITY	62.5VA, 60W

² Resistive load

HIGH VOLTAGE CIRCUIT

The high voltage circuit characteristics will vary with the motor and motor quantity of the Q-PAC Fan. This information is therefore given on the **Fan Controller Nameplate** as shown below. The table below provides an example of the high voltage circuit characteristics.

INPUT POWER

A	NOMINAL INPUT VOLTAGE	480V / 3~ / 60 Hz
	MAXIMUM INPUT VOLTAGE	600VAC
B	FLA PER MOTOR	7.86 A
C	MCA	72.70 A
D	MOCP	80.00 A

Q-PAC	RECOGNIZED COMPONENT	Q-PAC Fan Conforms to UL 60335-2-40:2022 Ed.4
	(904) 863-5300 SUPPORT@Q-PAC.COM 4010 DEERPARK BLVD ELKTON, FL 32033	Fan Controller Certified to UL 60730-2-15:2019 Ed.3
		US Pat. Nos. 11.852.151 11.375.085
	Intertek 4010006	
SO#:		9230
TAG:	7999 (K752) AHU-99-2 SF	
MODEL:	1-9-1-2-1-1700076	
SERIAL#:	23H9999	
MFG:	MM/DD/YYYY	
MODBUS ADDR:		017
POWER:		480V 3~ 60Hz
SCCR:	10kA RMS SYM AT 600 V MAX	
MTR FLA:	7.86 A	A
MCA:	72.70 A	B
MOCP:	80.00 A	C
		D
USE 15 AMP CLASS CC 600V FUSES		

TORQUE TIGHTENING REQUIREMENTS

BOLTED BUS JOINTS

SIZE	TORQUE (lb-ft)	TORQUE WITH BELLEVILLE WASHER (lb-ft)
1/4 in	4	-
5/16 in	9	-
3/8 in	14	14
1/2 in	39	35
5/8 in	80	45

SLOTTED HEAD SCREWS

SIZE	AWG / MCM	SLOT WIDTH	SLOT LENGTH	TORQUE (lb-ft)
#4 - #8	22 - 8	< 0.47 in	< 1/4 in	7
			1 / 4 in	9
		> 0.47 in	< 5/32 in	9
			5/32 - 1/4 in	12
			9/32 in	15
			> 9/32 in	20
#10 and Larger	18 - 10	< 0.47 in	< 1/4 in	20
	8			25
	6 - 3	> 0/47 in	> 1/4 in	35
	2			40
	18 - 10	> 0/47 in	> 1/4 in	35
	6 - 4			45
3 - 1000	50			

HEX HEAD SCREWS

EXTERNAL HEX

AWG / MCM	TORQUE (lb-ft)
18 - 8	75
6 - 4	110
3 - 1	150
1/0 - 2/0	180
3/0 - 4/0	250
250 - 350	325
400 - 750	375
800 - 1000	500
> 1000	600

INTERNAL HEX / SOCKET

SIZE	TORQUE (lb-in)
1/8 in	45
5/32 in	100
3/16 in	120
7/32 in	150
1/4 in	200
5/16 in	275
3/8 in	375
1/2 in	500
9/16 in	600

START-UP AND TESTING

BEFORE FIRST START-UP



Ensure the Q-PAC Fan has been fully assembled and installed per the **Q-PAC Fan Assembly Guide**. Do not attempt to wire the Control Panel, Q-PAC Fan Controller, or complete any electrical testing before assembly as been completed.

1. Ensure assembly and installation of the Q-PAC Fan(s) has been completed per the **Q-PAC Fan Assembly Guide**.
2. Secure the Control Panel to the wall or similar surface using the corner mounting tabs, following local building code requirements and ensuring suitable working clearance.
3. Complete all conduit and electrical connections per the **Wiring Diagram**. See **Pages 32-37** or the included order documents.
4. Ensure the **Safety Circuit** and **Start/Stop** are closed. If contractor has not already installed the **Safety Circuit** and **Start/Stop**, use a temporary jumper between **DI1** and **24VDC** and between **DI2** and **24VDC**.
5. Turn potentiometer to ZERO and HOA Switch to OFF.
6. Check that all electrical connections comply with the specifications on the **Fan Controller** and **Control Panel** nameplates.
7. Check all mounting bolts, plugs, and wiring connections to ensure they are secure. Refer to the **Wiring Guide (Pages 32-37)** and **Torque Requirements (Page 40)**.
8. Ensure all harnesses are secured to the fan frame, all cable ties are tight, and all plug connections are secure.
9. Rotate each impeller by hand to inspect for contact with the inlet cone. If contact is observed, refer to **Inlet Cone Alignment** instructions on **Page 104**. Contact may be present if any of the following are observed:
 - i. There is noticeable material transfer/residue on the inlet cone or other signs of scraping.
 - ii. When rotating the impeller, there is an audible rubbing or scraping sound.
 - iii. When rotating multiple impellers simultaneously, at even speeds, one impeller stops rotating considerably earlier than the other.
10. Remove all leftover installation materials and other foreign objects from the fan area and the rest of the air handler.
11. Ensure all personnel are out of reach of the impeller blades.

BUMP TEST



Ensure the test preparation as listed in **BEFORE FIRST START-UP** has been completed. Do not attempt to operate the Q-PAC Fan until all electrical connections have been verified.

1. Turn on the **Disconnect**.
2. Turn **HOA Switch** to **HAND**.
3. Turn **Potentiometer** slowly to **2**.
4. Check to see if the plug fan impellers are spinning. If not, check electrical connections. Ensure the **Safety Circuit** and **Start/Stop** are closed. If contractor has not already installed the **Safety Circuit** and **Start/Stop**, use a temporary jumper between **DI1** and **24VDC** and between **DI2** and **24VDC**.
5. Watch for any visual or audible signs that the plug fan impeller is making contact with the inlet cone. If found, refer to **Inlet Cone Alignment** instructions on **Page 104**.
6. Once rotation of the impellers is confirmed, observe the fan for quiet operation with low vibration. Strong vibration due to unbalanced operation or poor installation may result in motor or fan failure.
7. Turn **HOA Switch** to **OFF** and proceed to the **Control Panel HMI (Page 56)** to configure **Auto** mode and **BACnet Settings (Page 46)** as desired.

RUN TEST



Ensure the test preparation as listed in **BEFORE FIRST START-UP** and **BUMP TEST** have been completed. Do not attempt to operate the Q-PAC Fan until all electrical connections have been verified.

1. Turn on the **Disconnect**.
2. Turn **HOA Switch** to **AUTO**.
3. Check to see if the impellers are rotating. If not, turn off power to the fan and check the electrical connections in the Fan Controller and connected hardware. Check any included safety circuits or other protections and relays.
4. Once rotation of the impellers is confirmed, observe the fan for quiet operation with low vibration. Strong vibration due to unbalanced operation or poor installation may result in motor or fan failure.
5. Allow the fan to run for a minimum of five (5) minutes and ensure that it reaches steady-state operation—maintaining steady airflow for at least five (5) minutes with no alarms at the Control Panel. See the **HMI Home** screen (**Page 56**) or BACnet object **Analog Input 0 (Page 48)** for more information on alarms.
6. Turn off the **Disconnect**.

BACnet

GUIDE

SPECIFICATIONS

The Building Automation and Control Network (BACnet) is a data communication protocol for building automation and control networks. BACnet was developed by a committee formed by the American Society of Heating, Refrigerating and Air-Conditioning Engineers (ASHRAE). Described in ANSI/ASHRAE Standard 135-2020, BACnet is one of the most widely used building management system protocols. It operates in a client-server environment. A client machine sends a service request (message) to a server machine; once the service is performed the results are reported back to the client machine.

DATE	10/01/2024			
VENDOR NAME	Q-PAC Systems, Inc.			
PRODUCT NAME	Q-PAC Premium Control Package			
OBJECT NAME	Q-PAC			
APPLICATION SOFTWARE VERSION	4.4.0			
PLC FIRMWARE REVISION	F596.13			
BACNET PROTOCOL REVISION	12			
STANDARDIZED DEVICE PROFILE	BACnet Advanced Application Controller (B-AAC)			
INTEROPERABILITY BUILDING BLOCKS SUPPORTED	DS-RP-B	DS-WPM-B	DS-DDB-B	DM-RD-B
	DS-RPM-B	DS-COV-B	DS-BOB-B	DM-BR-B
	DS-RPC-B	DS-COVP-B	DM-TS-B	
	DS-WP-B	DS-COVU-B	DM-UTC-B	
SEGMENTATION CAPABILITY	Able to transmit segmented messages - Window Size: 16 Able to receive segmented messages - Window Size: 16			
STANDARD OBJECT TYPES SUPPORTED:	Analog Input Analog Value Binary Value Multi-state Input Multi-state Value			
DEVICE ADDRESS BINDING	Static device bonding not supported			
CHARACTER SETS SUPPORTED	ISO 10646 (UTF-8)			
DEVICE	Schneider Electric Modicon M172 Performance Display 42 I/Os, Eth, Isolated			
DEVICE INSTANCE	77077 (Default) [Range 1 - 4194302]			
DEVICE ADDRESS	01 (Default) [Range 1 - 255]			
DEVICE BACNET CONFORMANCE CERTIFICATE	No. BTL-30423			

MS/TP

CONNECTION	BACnet MS/TP
DATA LINK LAYER OPTIONS	MS/TP master (Clause 9), Baud rates: 9600, 19200, 38400, 57600, 76800, 115200 Baud

ETHERNET/IP

CONNECTION	BACnet/IP
DATA LINK LAYER OPTIONS	BACnet/IP (Annex J), UDP Port 47808 (Default)
NETWORK TYPE	Native BACnet/IP
IP ADDRESS	192.168.0.10 (Default)
SUBNET MASK	255.255.255.0 (Default)
DEFAULT GATEWAY	0.0.0.0 (Default)
UDP PORT	47808 (Default)
DHCP SUPPORT	Enabled or Disabled (Default: Disabled—Static IP)

OBJECT GUIDE

OBJECT TYPE	ID	OBJECT NAME	READ/WRITE	DESCRIPTION	RANGE	UNITS
ANALOG INPUT	0	Fan_Speed	Read Only	System modulation	0.0-100.0	%
ANALOG INPUT	1	System_Airflow	Read Only	Total volumetric airflow	0.0-500000.0	CFM
ANALOG INPUT	2	Power	Read Only	Total power usage	0.0-2147483647.0	Watts
ANALOG INPUT	3	Voltage	Read Only	Voltage reading	0.0-32767.0	Volts
ANALOG INPUT	4	Current	Read Only	Current reading	0.0-32767.0	Amps
ANALOG INPUT	5	Static_Pressure ¹	Read Only	Local duct pressure	0.0-15.0	in. WC
ANALOG VALUE	0	Fan_Speed_Input	Read/Write	Set system modulation via BACnet	0.0-100.0	%
ANALOG VALUE	1	Airflow_Setpoint	Read/Write	Constant airflow set point	0.0-500000.0	CFM
ANALOG VALUE	2	Static_Pressure_Setpoint ¹	Read/Write	Constant static pressure set point	0.0-15.0	in. WC

¹ Only available with external sensor and when system is set to **Constant Static Pressure** control type (Multistate Value 0 set to 3). For all other control types the object is disabled and will have the status Out of Service (OOS).

OBJECT TYPE	ID	OBJECT NAME	DESCRIPTION	VALUE
BINARY VALUE	0	Start_Stop	Start/Stop status	True = Start False = Stop
BINARY VALUE	1	System_Run	System Run enabled / disabled	True = On False = Off
BINARY VALUE	2	Interlock_Toggle	Interlock feature toggle	True = Enabled False = Disabled
BINARY VALUE	3	Q-PAC_Fan_A_Motor_1 ²	Status of motor 1 of first Q-PAC Fan	True = Operational False = Not Operational
BINARY VALUE	4	Q-PAC_Fan_A_Motor_2 ²	Status of motor 2 of first Q-PAC Fan	True = Operational False = Not Operational
BINARY VALUE	5	Q-PAC_Fan_A_Motor_3 ²	Status of motor 3 of first Q-PAC Fan	True = Operational False = Not Operational
BINARY VALUE	6	Q-PAC_Fan_A_Motor_4 ²	Status of motor 4 of first Q-PAC Fan	True = Operational False = Not Operational
BINARY VALUE	7	Q-PAC_Fan_A_Motor_5 ²	Status of motor 5 of first Q-PAC Fan	True = Operational False = Not Operational
BINARY VALUE	8	Q-PAC_Fan_A_Motor_6 ²	Status of motor 6 of first Q-PAC Fan	True = Operational False = Not Operational
BINARY VALUE	9	Q-PAC_Fan_A_Motor_7 ²	Status of motor 7 of first Q-PAC Fan	True = Operational False = Not Operational
BINARY VALUE	10	Q-PAC_Fan_A_Motor_8 ²	Status of motor 8 of first Q-PAC Fan	True = Operational False = Not Operational
BINARY VALUE	11	Q-PAC_Fan_A_Motor_9 ²	Status of motor 9 of first Q-PAC Fan	True = Operational False = Not Operational
BINARY VALUE	12	Q-PAC_Fan_B_Motor_1 ²	Status of motor 1 of second Q-PAC Fan	True = Operational False = Not Operational

² The fan system is comprised of up to four Q-PAC Fans, which may contain up to nine motors. Fans and motors not present in smaller systems will display as Out of Service (OOS).

OBJECT TYPE	ID	OBJECT NAME	DESCRIPTION	VALUE
BINARY VALUE	13	Q-PAC_Fan_B_Motor_2 ²	Status of motor 2 of second Q-PAC Fan	True = Operational False = Not Operational
BINARY VALUE	14	Q-PAC_Fan_B_Motor_3 ²	Status of motor 3 of second Q-PAC Fan	True = Operational False = Not Operational
BINARY VALUE	15	Q-PAC_Fan_B_Motor_4 ²	Status of motor 4 of second Q-PAC Fan	True = Operational False = Not Operational
BINARY VALUE	16	Q-PAC_Fan_B_Motor_5 ²	Status of motor 5 of second Q-PAC Fan	True = Operational False = Not Operational
BINARY VALUE	17	Q-PAC_Fan_B_Motor_6 ²	Status of motor 6 of second Q-PAC Fan	True = Operational False = Not Operational
BINARY VALUE	18	Q-PAC_Fan_B_Motor_7 ²	Status of motor 7 of second Q-PAC Fan	True = Operational False = Not Operational
BINARY VALUE	19	Q-PAC_Fan_B_Motor_8 ²	Status of motor 8 of second Q-PAC Fan	True = Operational False = Not Operational
BINARY VALUE	20	Q-PAC_Fan_B_Motor_9 ²	Status of motor 9 of second Q-PAC Fan	True = Operational False = Not Operational
BINARY VALUE	21	Q-PAC_Fan_C_Motor_1 ²	Status of motor 1 of third Q-PAC Fan	True = Operational False = Not Operational
BINARY VALUE	22	Q-PAC_Fan_C_Motor_2 ²	Status of motor 1 of third Q-PAC Fan	True = Operational False = Not Operational
BINARY VALUE	23	Q-PAC_Fan_C_Motor_3 ²	Status of motor 2 of third Q-PAC Fan	True = Operational False = Not Operational
BINARY VALUE	24	Q-PAC_Fan_C_Motor_4 ²	Status of motor 3 of third Q-PAC Fan	True = Operational False = Not Operational
BINARY VALUE	25	Q-PAC_Fan_C_Motor_5 ²	Status of motor 4 of third Q-PAC Fan	True = Operational False = Not Operational

² The fan system is comprised of up to four Q-PAC Fans, which may contain up to nine motors. Fans and motors not present in smaller systems will display as Out of Service (OOS).

OBJECT TYPE	ID	OBJECT NAME	DESCRIPTION	VALUE
BINARY VALUE	26	Q-PAC_Fan_C_Motor_6 ²	Status of motor 6 of third Q-PAC Fan	True = Operational False = Not Operational
BINARY VALUE	27	Q-PAC_Fan_C_Motor_7 ²	Status of motor 7 of third Q-PAC Fan	True = Operational False = Not Operational
BINARY VALUE	28	Q-PAC_Fan_C_Motor_8 ²	Status of motor 8 of third Q-PAC Fan	True = Operational False = Not Operational
BINARY VALUE	29	Q-PAC_Fan_C_Motor_9 ²	Status of motor 9 of third Q-PAC Fan	True = Operational False = Not Operational
BINARY VALUE	30	Q-PAC_Fan_D_Motor_1 ²	Status of motor 1 of fourth Q-PAC Fan	True = Operational False = Not Operational
BINARY VALUE	31	Q-PAC_Fan_D_Motor_2 ²	Status of motor 2 of fourth Q-PAC Fan	True = Operational False = Not Operational
BINARY VALUE	32	Q-PAC_Fan_D_Motor_3 ²	Status of motor 3 of fourth Q-PAC Fan	True = Operational False = Not Operational
BINARY VALUE	33	Q-PAC_Fan_D_Motor_4 ²	Status of motor 4 of fourth Q-PAC Fan	True = Operational False = Not Operational
BINARY VALUE	34	Q-PAC_Fan_D_Motor_5 ²	Status of motor 5 of fourth Q-PAC Fan	True = Operational False = Not Operational
BINARY VALUE	35	Q-PAC_Fan_D_Motor_6 ²	Status of motor 6 of fourth Q-PAC Fan	True = Operational False = Not Operational
BINARY VALUE	36	Q-PAC_Fan_D_Motor_7 ²	Status of motor 7 of fourth Q-PAC Fan	True = Operational False = Not Operational
BINARY VALUE	37	Q-PAC_Fan_D_Motor_8 ²	Status of motor 8 of fourth Q-PAC Fan	True = Operational False = Not Operational
BINARY VALUE	38	Q-PAC_Fan_D_Motor_9 ²	Status of motor 9 of fourth Q-PAC Fan	True = Operational False = Not Operational

² The fan system is comprised of up to four Q-PAC Fans, which may contain up to nine motors. Fans and motors not present in smaller systems will display as Out of Service (OOS).

OBJECT TYPE	ID	OBJECT NAME	READ/WRITE	DESCRIPTION	VALUE
MULTISTATE INPUT	0	InterLock_Status	Read Only	Interlock status	1 = Overridden 2 = Engaged 3 = Disengaged
MULTISTATE INPUT	1	Fireman_Override_Status	Read Only	Fireman Override status	1 = Overridden 2 = Engaged 3 = Disengaged
MULTISTATE INPUT	2	System_Status	Read Only	System status	1 = Safety Circuit triggered 2 = HOA: Off 3 = HOA: Hand mode 4 = Fireman Override active 5 = Start/Stop: Off 6 = Interlock engaged 7 = Disabled 8 = Control Panel alarm 9 = Q-PAC Fan alarm 10 = OK

SYSTEM STATUS DESCRIPTIONS

SAFETY CIRCUIT TRIGGERED	DI1 does not have 24VFD applied to it from terminal 24V . Check all safety sensors.
HOA: OFF	The HOA switch on the Control Panel is set to OFF .
HOA: HAND MODE	The HOA switch on the Control Panel is set to HAND .
FIREMAN OVERRIDE ACTIVE	Fireman Override is enabled for use and activated.
START/STOP: OFF	DI2 does not have 24VAC applied to it from the terminal 24V .
INTERLOCK ENGAGED	Interlock feature is engaged; all processes are halted.
DISABLED	System Run switch is set to DISABLED in Binary Value 1 or Operation Settings .
CONTROL PANEL ALARM	Check Control Panel display for error (See Pages 70-73).
Q-PAC FAN ALARM	Check Control Panel display for Q-PAC Fan fault (See Pages 70-73).
OK	None of the above statuses are active; system is in a ready state.

Object Type	ID	Object Name	Read/Write	Description	Value
MULTIISTATE INPUT	3	Q-PAC_Fan_A_Status	Read Only	Status of first Q-PAC Fan	1 = OK 2 = Fault 3 = Not in use
MULTIISTATE INPUT	4	Q-PAC_Fan_B_Status	Read Only	Status of second Q-PAC Fan	1 = OK 2 = Fault 3 = Not in use
MULTIISTATE INPUT	5	Q-PAC_Fan_C_Status	Read Only	Status of third Q-PAC Fan	1 = OK 2 = Fault 3 = Not in use
MULTIISTATE INPUT	6	Q-PAC_Fan_D_Status	Read Only	Status of fourth Q-PAC Fan	1 = OK 2 = Fault 3 = Not in use
MULTIISTATE VALUE	0	Control_Type	Read/Write	Control type	1 = 0 - 10 VDC 2 = Constant Airflow 3 = Constant Static Pressure 4 = BACnet

CONTROL PANEL
HMI

OVERVIEW

This HMI user guide is to be used for the setup, operation, and maintenance of the Q-PAC Fan through the use of Q-PAC Premium Control Panel.

This guide is intended for use with the following software version(s):

Application Software Version(s): 4.4.0
HMI Software Version(s): 1.3.0

CHECK ELECTRICAL CONNECTIONS

Before operating the Control Panel, verify all connections inside the Control Panel and Fan Controller(s) are properly connected and secure per the **Wiring Guides (Pages 30-35)**.

SETUP REQUIRED

Each Control Panel is factory-tested, but requires manual setup upon installation.

USER ACCOUNTS

Upon starting the Control Panel and accessing the HMI, the Q-PAC splash screen will appear before loading into the **Home Screen**. Select **Settings [1]** to log into the **User Account** and configure the Control Panel.

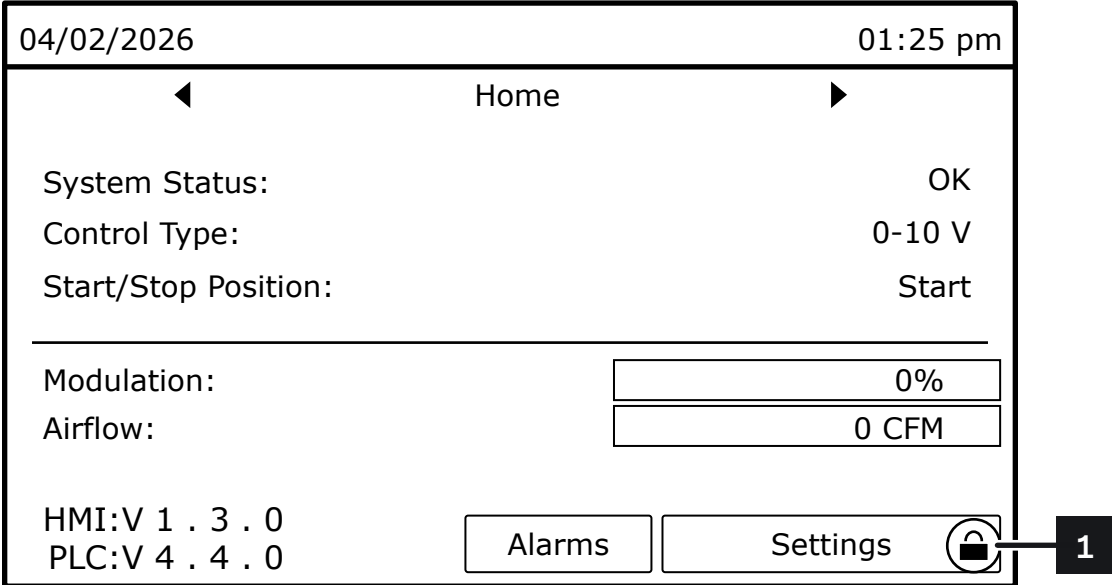

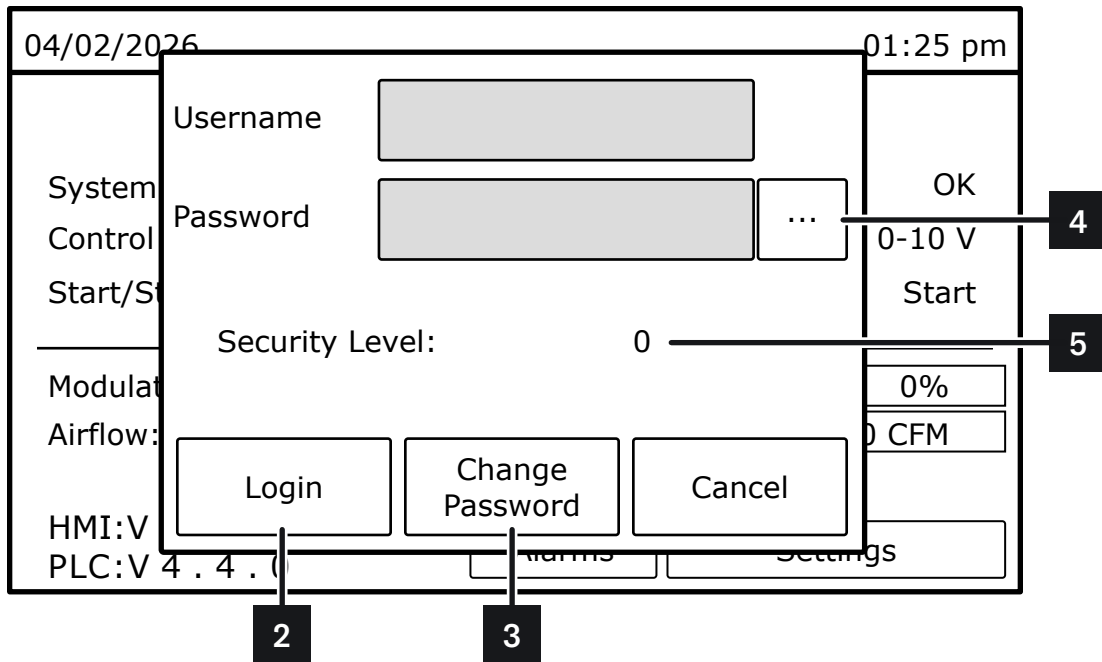

The controller uses multiple account levels to restrict access to settings, helping prevent unintended changes that could impact system performance or operation. Refer to Page 58 for user account information.

		<u>Description</u>						
1	LOCK ICON	Signifies that the HMI is currently not logged into any user account and will only have access to status screens.						
2	LOGIN	Submit the entered credentials to access the indicated account.						
3	CHANGE PASSWORD	Opens a new window allowing the user to update an account's password to one of the user's preference.						
4	SHOW PASSWORD	Displays the current password entered; characters are masked as asterisks (*) by default.						
5	SECURITY LEVEL	Represents the current level of access, as described below. <table border="1" style="margin-left: 20px;"> <tbody> <tr> <td style="text-align: center;">LEVEL 0</td> <td>This is the base level of access, without logging into any user account. Only allows access to the status screens: Home, Network, Q-PAC Fan Motor Status, Power Monitoring, Relay Status, and Alarms and Events.</td> </tr> <tr> <td style="text-align: center;">LEVEL 1</td> <td>Allows access to the Settings menu for access to most controller settings: Operation Settings, System Settings, Alarm Logs, and Panel Configurations.</td> </tr> <tr> <td style="text-align: center;">LEVEL 2</td> <td>Allows access to all Level 1 features as well as controller network settings for BACnet/IP configuration.</td> </tr> </tbody> </table>	LEVEL 0	This is the base level of access, without logging into any user account. Only allows access to the status screens: Home, Network, Q-PAC Fan Motor Status, Power Monitoring, Relay Status, and Alarms and Events.	LEVEL 1	Allows access to the Settings menu for access to most controller settings: Operation Settings, System Settings, Alarm Logs, and Panel Configurations.	LEVEL 2	Allows access to all Level 1 features as well as controller network settings for BACnet/IP configuration.
LEVEL 0	This is the base level of access, without logging into any user account. Only allows access to the status screens: Home, Network, Q-PAC Fan Motor Status, Power Monitoring, Relay Status, and Alarms and Events.							
LEVEL 1	Allows access to the Settings menu for access to most controller settings: Operation Settings, System Settings, Alarm Logs, and Panel Configurations.							
LEVEL 2	Allows access to all Level 1 features as well as controller network settings for BACnet/IP configuration.							

USER ACCOUNT INFORMATION

USER ACCOUNT

The User Account grants access to:

- Operation Settings
- System Settings
- Alarm Logs
- Panel Configuration

The login credentials are given below. If this is the first time accessing the Control Panel settings, it is recommended to change the account password by selecting **Change Password [3]**. Record the new password below.

Username: ADMIN
Password: 0000

New Password: _____

ADVANCED USER ACCOUNT

The Advanced User Account grants access to:

- BACnet/IP Configuration
- Manufacturer Settings



USE ONLY AS REQUIRED

Changing the BACnet/IP address can interfere with HMI communication. Use this account only as needed to adjust the ethernet settings. For all other settings, use the User Admin Account above.

The login credentials are given below. If this is the first time accessing the Control Panel settings, it is recommended to change the account password by selecting **Change Password [3]**. Record the new password below.

Username: QPAC
Password: 369

New Password: _____

SERVICE ACCOUNT

The **Service Account** is a separate account which grants access to **Manufacturer Settings**. This menu is only intended to be used for cases in when EEPROM variables of the programmable controller have been reset to their factory settings.

This menu is only to be accessed by or with the assistance of Q-PAC Support. If needing to access Manufacturer Settings, please contact **Q-PAC Support** at **904-863-5300** or **support@q-pac.com**.

CHANGE USER ACCOUNT PASSWORD

! Before changing the password, ensure that all users have logged off and the **Settings** menu is locked.

The image displays two screenshots of a control panel interface. The top screenshot shows a dialog box with the following elements: a date/time header (04/02/2026 01:25 pm), a 'Username' field, a 'Password' field with a dropdown arrow, a 'Security Level: 0' indicator, and three buttons: 'Login', 'Change Password', and 'Cancel'. A callout box with the number '1' points to the 'Change Password' button. The bottom screenshot shows the same dialog box after the 'Change Password' button is selected. It now includes a 'New Password' field and a 'Confirm Password' field. A callout box with the number '4' points to the 'Change' button. Other callout boxes with numbers '2' and '3' point to the 'Password' and 'New Password' fields respectively. The background of the control panel shows various system parameters like 'System Control Start/Stop', 'Modulation Airflow: 0%', and 'HMI:V PLC:V 4.4.0'.

To change the **User Account** password:

1. Select **Change** [1] from the **Settings** login window.
2. Enter the current **User Account** username and password [2] (**Page 58**).
3. Select a new password and enter it into the **New Password** and **Confirm Password** [3] fields.
4. Select **Change** [4] to save the new password.
It is strongly encouraged to record the new password on **Page 58** for future reference.

THIS PAGE IS INTENTIONALLY BLANK

SETTINGS MENU

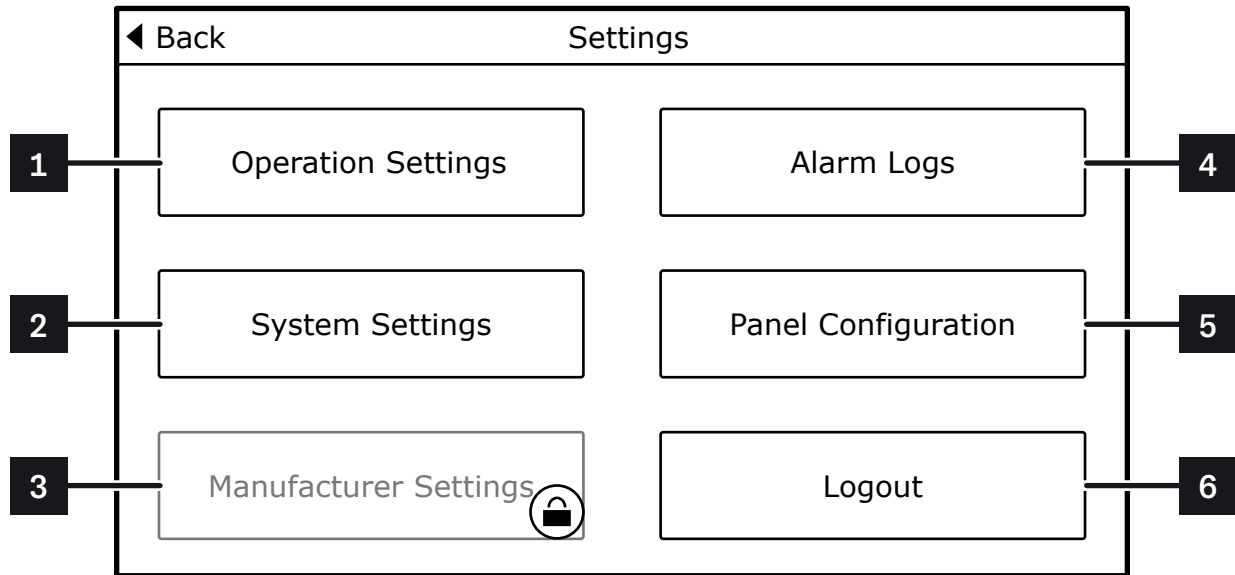

1 OPERATION SETTINGS

- CONTROL SETTINGS 62
- AIRFLOW PID SETTINGS 63
- STATIC PRESSURE PID SETTINGS 64
- RELAY AND RAMP SETTINGS 65

2 SYSTEM SETTINGS

- NETWORK SETTINGS 66
- FIREMAN OVERRIDE 74
- INTERLOCK 76
- FAN LAYOUT 77

3 MANUFACTURER SETTINGS 95

Provides access to modify the EEPROM variables of the controller and requires use of the Advanced User Account or Q-PAC Service Account.

4 ALARM LOGS

- ALARMS 81
- ALARM CODES 83
- EVENTS 84

5 PANEL CONFIGURATION

- DATE AND TIME 86
- OTHER SETTINGS 87

6 LOGOUT

Lock **Settings** menu and return to **Home** screen.

OPERATION SETTINGS

CONTROL SETTINGS

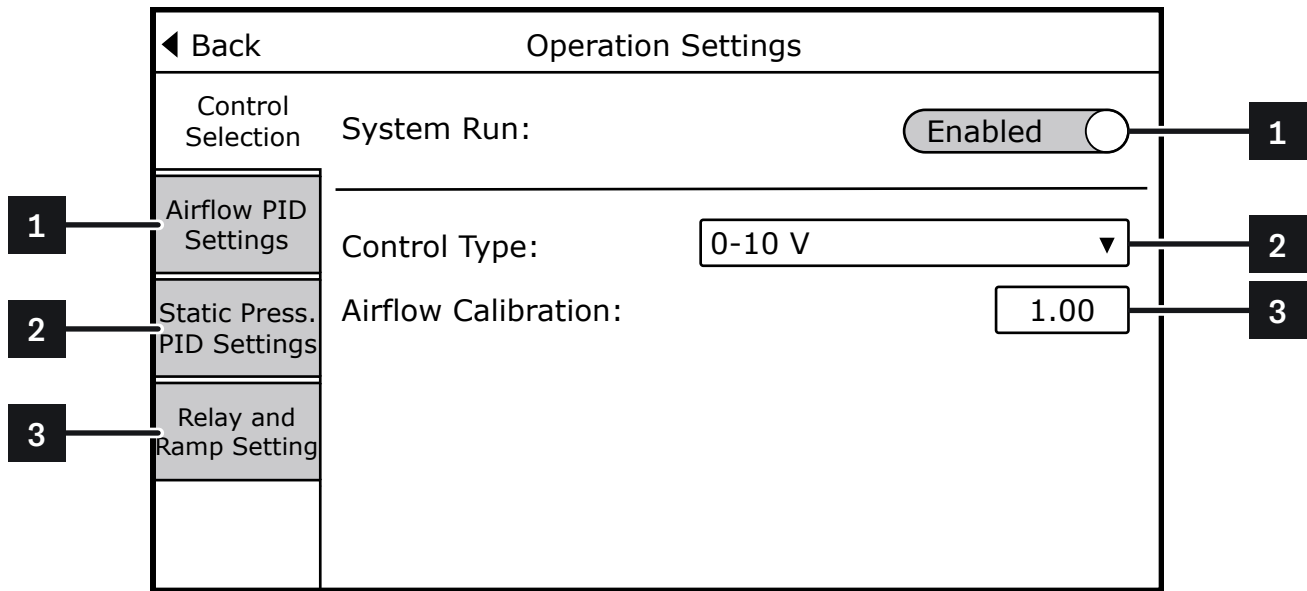

To prepare the system for operation, ensure **System Run** [4] is set to **Enabled** and that the desired **Control Type** [5] is selected.

		<u>Options</u>	<u>Description</u>	<u>Default</u>
1	SYSTEM RUN	Enabled Disabled	Enable or disable the system from operating. Also accessible via BACnet object Binary Value 1 (Page 49) .	Enabled
2	CONTROL TYPE	0 - 10 VDC Constant Static Pressure ¹ Constant Airflow ¹ BACnet ²	0 to 10 VDC signal between terminals AI1 and COM . Locally control motor speed to maintain a constant duct static pressure. Locally control the motor speed for a constant volume of airflow. Input a 0 to 100% speed signal into the BACnet object to control motor speed.	
3	AIRFLOW CALIBRATION	0.0 - 1.5	Multiplier to manually tune the measured airflow to match other system instrumentation.	1.0
4	AIRFLOW PID SETTINGS		See Page 63 .	
5	STATIC PRESSURE PID SETTINGS		See Page 64 .	
6	RELAY AND RAMP SETTINGS		See Page 65 .	

¹Set point adjustable locally or via BACnet.

²Set point adjustable via BACnet only.

AIRFLOW PID SETTINGS

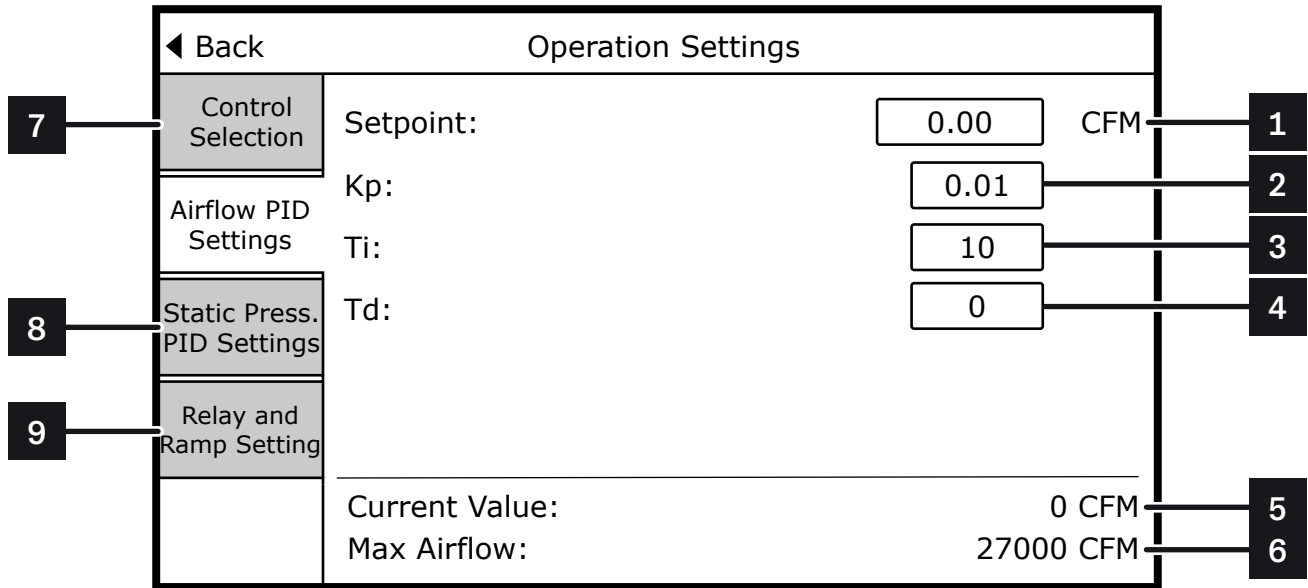

If using the **Constant Airflow Control Type**, configure the PID settings as given below:

1. Enter the airflow **Set point** [1].
2. Increase **Kp** [2] as necessary for reaction time and steady state error, using recommended increments of 0.01.

		<u>Options</u>	<u>Description</u>	<u>Default</u>
1	SETPOINT	0 - Max Airflow	Required airflow (CFM) for the Constant Airflow Control Type (Page 62)	0
2	KP		Multiplier to tune the measured airflow to match other instrumentation measurements. Recommended to adjust in increments of 0.01.	0.01
3	TI		Tuning parameter; recommended to keep at default.	1
4	TD		Tuning parameter; recommended to keep at default.	0
5	CURRENT VALUE		Current measured airflow (CFM).	-
6	MAX AIRFLOW		Approximate maximum airflow possible based on the plug fan(s) installed in the system, regardless of static pressure. This also represents the maximum value for the BACnet object Analog Input 1 and is used to interpolate the value from AO1 and COM to BMS for airflow.	-
7	CONTROL SETTINGS		See Page 62.	
8	STATIC PRESSURE PID SETTINGS		See Page 64.	
9	RELAY AND RAMP SETTINGS		See Page 65.	

STATIC PRESSURE PID SETTINGS

If using the **Constant Static Pressure Control Type**, configure the PID settings as given below:

1. Enter the static pressure **Set point** [1].
2. Increase **Kp** [2] as necessary for reaction time and steady state error, using recommended increments of 0.01.
3. Select the **Pressure Transducer Range** [5] corresponding to the static pressure of the system.

		<u>Options</u>	<u>Description</u>	<u>Default</u>
1	SETPOINT	0 - Max Static Pressure	Required static pressure (in. WC) for the Constant Static Pressure Control Type (Page 62)	0
2	KP		Multiplier to tune the measured airflow to match other instrumentation measurements.	0.01
3	TI		Tuning parameter; recommended to keep at default.	1
4	TD		Tuning parameter; recommended to keep at default.	0
5	P.T. RANGE	0 - 10 in. WC 0 - 15 in. WC	Recommended for systems at 10 in. WC or less. Recommended for systems at 10 in. WC or more.	0-10 in. WC
6	CURRENT VALUE	-	Current measured static pressure (in. WC).	
7	CONTROL SELECTION		See Page 62.	
8	AIRFLOW PID SETTINGS		See Page 63.	
9	RELAY AND RAMP SETTINGS		See Page 65.	

RELAY AND RAMP SETTINGS

Operation Settings

Control Selection (7)

Airflow PID Settings (8)

Static Press. PID Settings (9)

Relay and Ramp Setting

Relay Settings

R01 Delay Open: 0 Sec (1)

R01 Delay Close: 0 Sec (2)

Delay on Start

Delay on Start: 5 Sec (3)

Passive Ramp Control

Enable Feature: Enabled (4)

Ramp Up Time: 10 Sec (5)

Ramp Down Time: 10 Sec (6)

Adjust the minimum and maximum set points for delay and timing of features and relays as desired.

		Options	Description	Default
1	R01 RELAY OPEN		Delay to open relay when conditions are met	5 Sec
2	R01 DELAY CLOSE		Delay to close relay when conditions are met.	5 Sec
3	DELAY ON START		Delay on start when HOA switch is in Auto mode. This requires the following conditions are met: <ul style="list-style-type: none"> ▪ Safety Circuit is Closed ▪ Enable/Disable Switch set to Enabled ▪ Start/Stop set to Start ▪ HOA Switch set to Auto 	5 Sec
4	ENABLE FEATURE	Enabled Disabled	Enable or disable Ramp feature controls.	Enabled
5	RAMP UP	10 - 600 Sec	Duration of time to ramp up speed, if enabled.	10 Sec
6	RAMP DOWN	5 - 600 Sec	Duration of time to ramp down speed, if enabled.	5 Sec
7	CONTROL SELECTION		See Page 62.	
8	AIRFLOW PID SETTINGS		See Page 63.	
9	STATIC PRESSURE PID SETTINGS		See Page 64.	

SYSTEM SETTINGS

NETWORK SETTINGS

BACNET MSTP

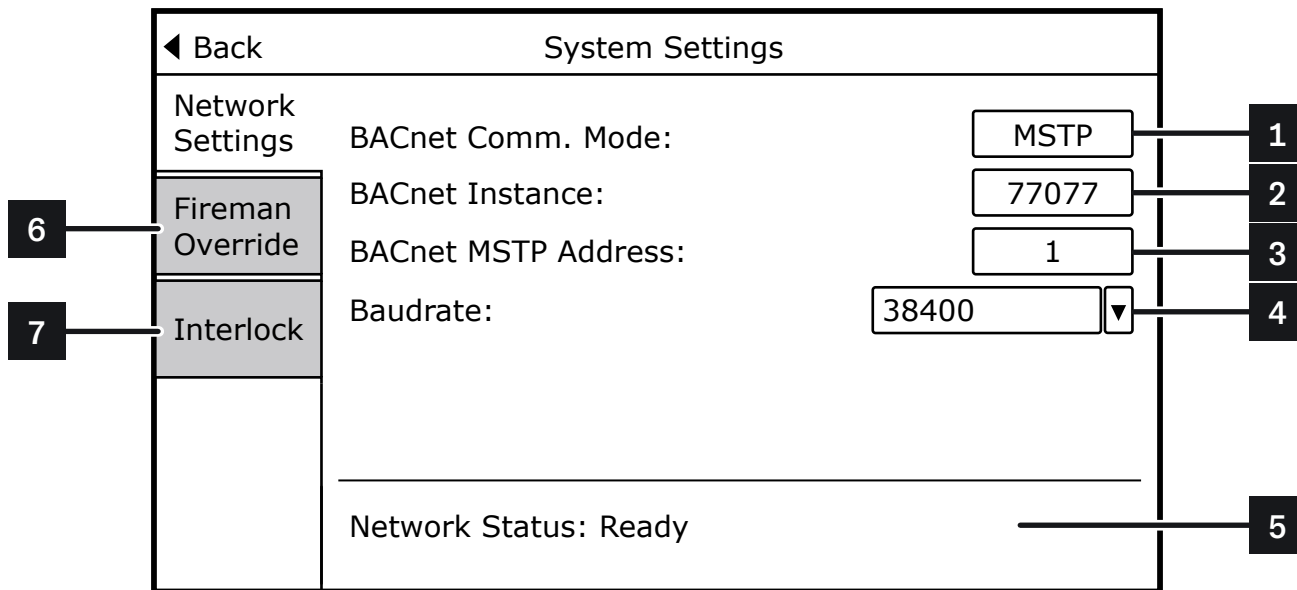

1. Set the **BACnet Communication Mode** [1] to **MSTP**.
2. Adjust the **Baudrate** [4] as necessary for communication with other devices in the system.
3. Adjust the **BACnet Address** [3] and **Instance** [2] settings as applicable. See **Page 46** for more information.

		<u>Options</u>	<u>Description</u>	<u>Default</u>
1	BACNET COMMUNICATION MODE	MSTP	Communication over RS-485 wiring.	IP
		IP	Communication over standard Ethernet/IP networks.	
2	BACNET INSTANCE		Device instance for MSTP communication.	77077
3	BACNET MSTP ADDRESS		Device address for MSTP communication.	1
4	BAUDRATE	9600 Baud	Baudrate for MSTP communication.	38400 Baud
		19200 Baud		
		38400 Baud		
		57600 Baud		
		76800 Baud		
		115200 Baud		
5	NETWORK STATUS	Ready	Network settings are ready for use.	
		Restart Control Panel Power	Network settings have been updated and the Control Panel needs to be restarted	
6	FIREMAN OVERRIDE		See Page 74 .	
7	INTERLOCK		See Page 76 .	

BACNET/IP

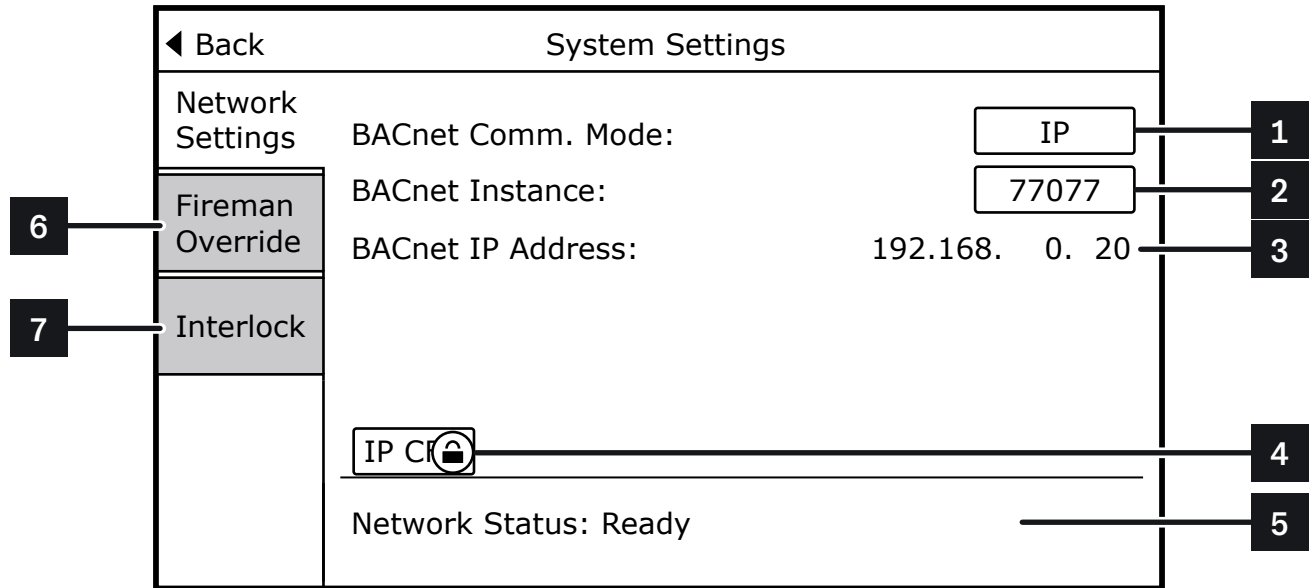

1. Confirm the **BACnet Communication Mode** [1] is set to IP.
2. Press **IP CFG** [4] to access the Advanced Network Settings. If locked, enter the **Advanced User Account** credentials (**Page 58**) when prompted.

	<u>Options</u>	<u>Description</u>	<u>Default</u>
1	BACNET COMMUNICATION MODE	MSTP Communication over RS-485 wiring for building control networks. IP Communication over standard Ethernet/IP networks.	IP
2	BACNET INSTANCE	Device instance for MSTP communication.	77077
3	BACNET IP ADDRESS	Device address for Bacnet/IP communication.	192.168.0.10
4	IP CONFIGURATION	Configure BACnet/IP address, subnet mask, and default gateway for IP communication.	
5	NETWORK STATUS	Ready Network settings are ready for use. Restart Control Panel Power Network settings have been updated and the Control Panel needs to be restarted.	
6	FIREMAN OVERRIDE	See Page 74 .	
7	INTERLOCK	See Page 76 .	

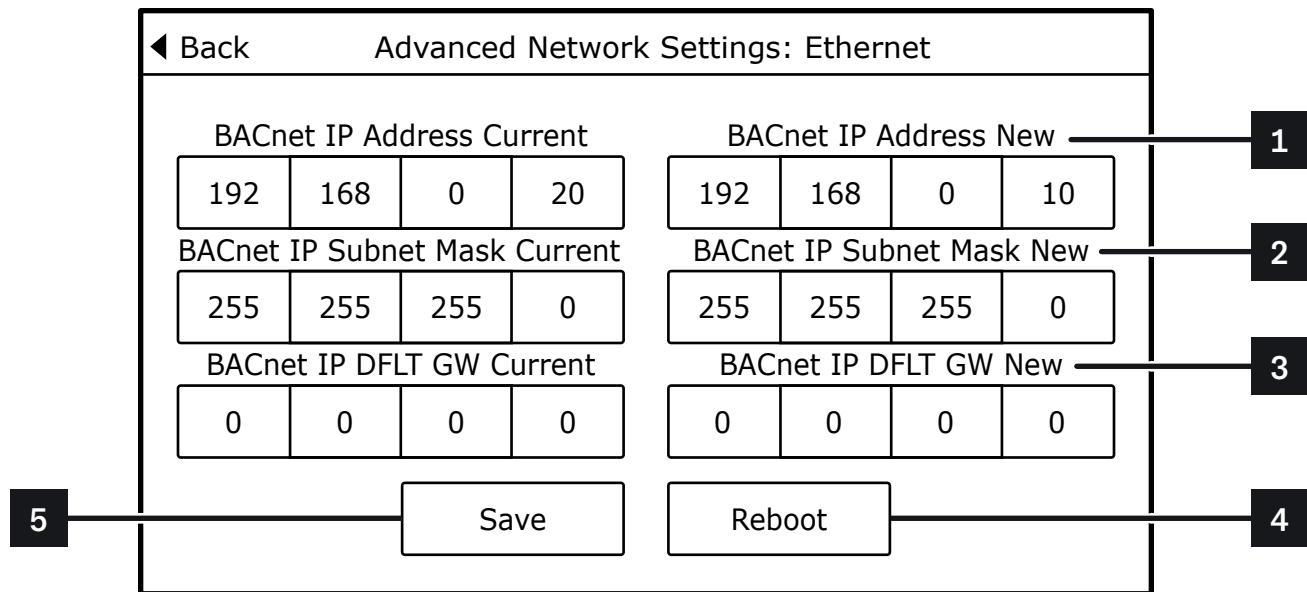

UPDATING THE BACNET/IP ADDRESS (FOURTH OCTET ONLY)

Updating the fourth octet (fourth set of digits) of the BACnet/IP address is straightforward. Update the fourth octet of **BACnet IP Address New** [1] and select **Save**.



DO NOT USE "12" FOR THE FOURTH OCTET

This assignment is used by the HMI display. Saving may cause an IP conflict and the HMI display will lose access to most settings. The HMI will display a warning if attempting to save a new address that causes conflict.

		<u>Options</u>	<u>Description</u>	<u>Default</u>
1	BACNET IP ADDRESS	0-255, per octet	BACnet/IP address assigned to the device.	192.168.0.10
		Current	Current address.	-
		New	Updated address. Changes take effect after selecting Save and Reboot .	-
2	BACNET IP SUBNET MASK	0-255, per octet	Subnet mask assigned to the device.	255.255.255.0
		Current	Current subnet mask.	-
		New	Updated subnet mask. Changes take effect after selecting Save and Reboot .	-
3	BACNET IP DEFAULT GATEWAY	0-255, per octet	Default gateway assigned to the device.	0.0.0.0
		Current	Current default gateway.	-
		New	Updated gateway. Changes take effect after selecting Save and Reboot .	-
4	REBOOT		Restart the Control Panel HMI to apply saved network settings.	
5	SAVE		Save the changes made to the Network Settings. A reboot is required for the changes to take effect.	

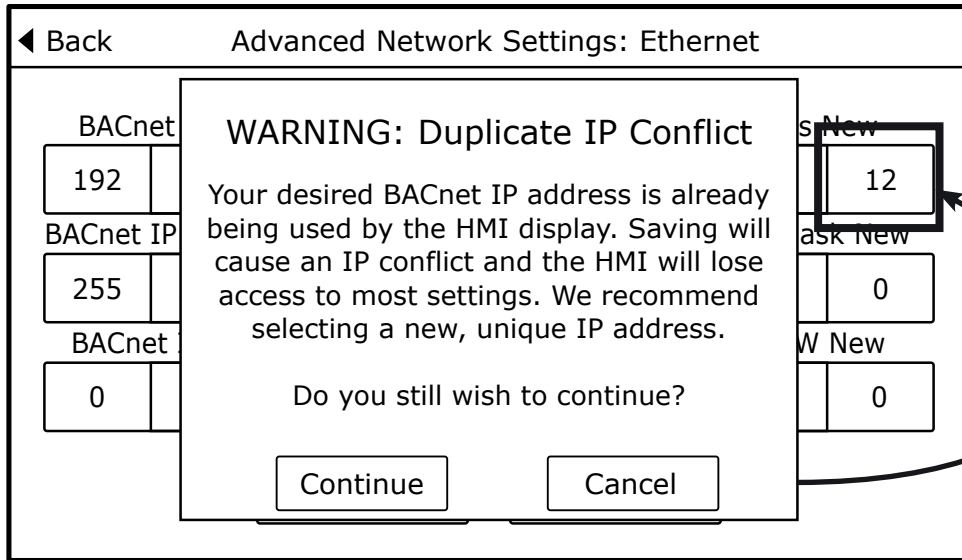

As a reminder, the HMI will generate a warning if attempting to assign a new IP address with the number "12" for the fourth octet, as this address is used by the HMI.

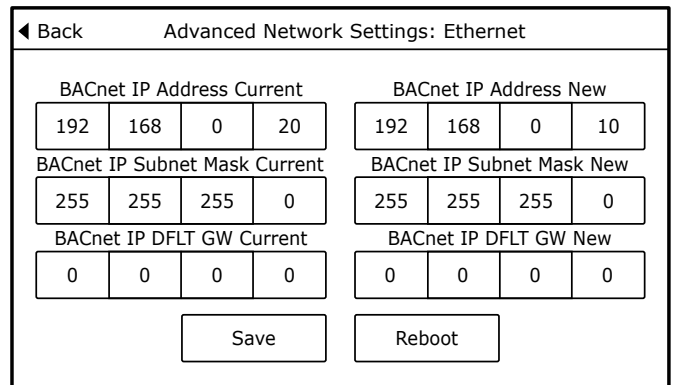
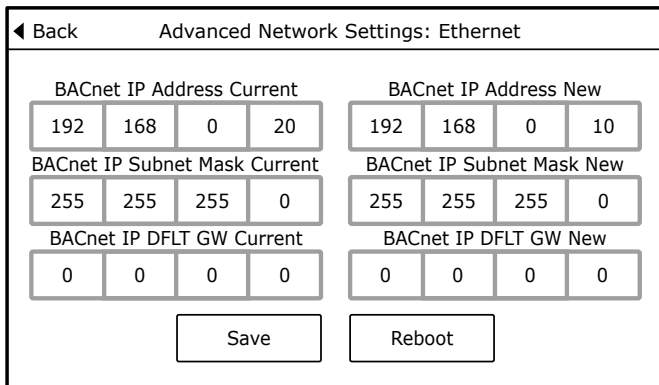

After selecting **Save**, the HMI will display red outlines around each field. Wait for these outlines to disappear, and confirm that the New and Current addresses match. This means communication is established and the IP change is successful.

Returning to **System Settings** will show that the change is reflected.

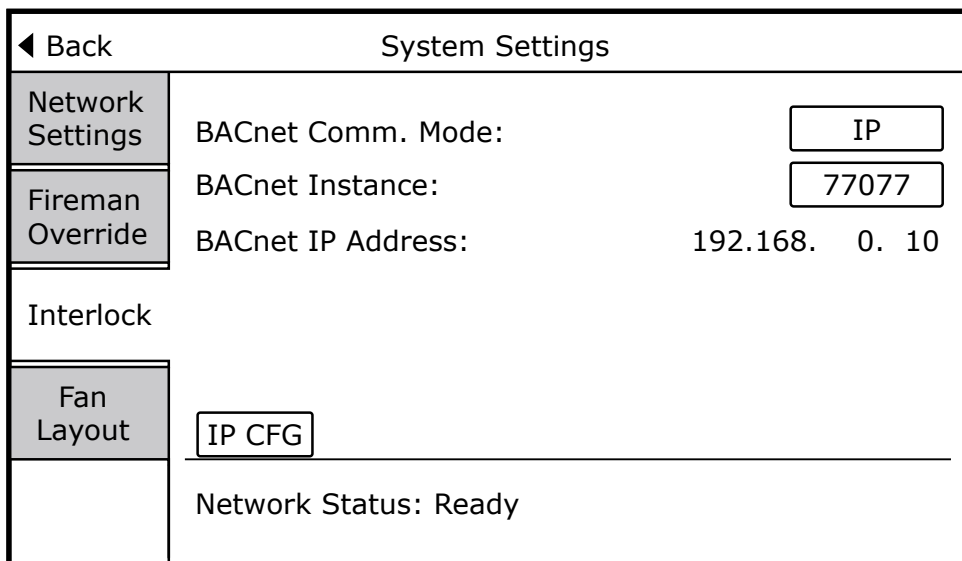

UPDATING THE BACNET/IP ADDRESS, SUBNET MASK, OR DEFAULT GATEWAY

Updating the first three octets of the IP address, or either the Subnet Mask or Default Gateway will require some additional steps. In this example, the IP address will be updated from 192.168.000.020 to 192.168.001.025.

1. As done earlier, open the Advanced Network Settings. Update the third and fourth octet of **BACnet IP Address New**.

◀ Back **Advanced Network Settings: Ethernet**

BACnet IP Address Current	BACnet IP Address New								
<table border="1" style="width: 100%; border-collapse: collapse;"> <tr> <td style="width: 25%; text-align: center;">192</td> <td style="width: 25%; text-align: center;">168</td> <td style="width: 25%; text-align: center;">0</td> <td style="width: 25%; text-align: center;">20</td> </tr> </table>	192	168	0	20	<table border="1" style="width: 100%; border-collapse: collapse;"> <tr> <td style="width: 25%; text-align: center;">192</td> <td style="width: 25%; text-align: center;">168</td> <td style="width: 25%; text-align: center;">1</td> <td style="width: 25%; text-align: center;">25</td> </tr> </table>	192	168	1	25
192	168	0	20						
192	168	1	25						
BACnet IP Subnet Mask Current	BACnet IP Subnet Mask New								
<table border="1" style="width: 100%; border-collapse: collapse;"> <tr> <td style="width: 25%; text-align: center;">255</td> <td style="width: 25%; text-align: center;">255</td> <td style="width: 25%; text-align: center;">255</td> <td style="width: 25%; text-align: center;">0</td> </tr> </table>	255	255	255	0	<table border="1" style="width: 100%; border-collapse: collapse;"> <tr> <td style="width: 25%; text-align: center;">255</td> <td style="width: 25%; text-align: center;">255</td> <td style="width: 25%; text-align: center;">255</td> <td style="width: 25%; text-align: center;">0</td> </tr> </table>	255	255	255	0
255	255	255	0						
255	255	255	0						
BACnet IP DFLT GW Current	BACnet IP DFLT GW New								
<table border="1" style="width: 100%; border-collapse: collapse;"> <tr> <td style="width: 25%; text-align: center;">0</td> <td style="width: 25%; text-align: center;">0</td> <td style="width: 25%; text-align: center;">0</td> <td style="width: 25%; text-align: center;">0</td> </tr> </table>	0	0	0	0	<table border="1" style="width: 100%; border-collapse: collapse;"> <tr> <td style="width: 25%; text-align: center;">0</td> <td style="width: 25%; text-align: center;">0</td> <td style="width: 25%; text-align: center;">0</td> <td style="width: 25%; text-align: center;">0</td> </tr> </table>	0	0	0	0
0	0	0	0						
0	0	0	0						
<div style="border: 1px solid black; width: 100px; height: 30px; margin: 0 auto;">Save</div>	<div style="border: 1px solid black; width: 100px; height: 30px; margin: 0 auto;">Reboot</div>								

2. After pressing **Save**, the fields will again outline in red.
3. Return to the **Network Settings** screen. The **BACnet IP Address** field will update with a red outline before updating again after a few seconds, as shown below. The HMI may appear to glitch during this process.

◀ Back **System Settings**

Network Settings	BACnet Comm. Mode: MSTP	
Fireman Override	BACnet Instance: 77077	
Interlock	BACnet IP Address: 192 168 1 25	
Fan Layout	Baudrate: ▼	
	IP CFG	
Network Status: Restart Control Panel Power		

◀ Back **System Settings**

Network Settings	BACnet Comm. Mode: MSTP	
Fireman Override	BACnet Instance: 77077	
Interlock	BACnet MSTP Address: 1	
Fan Layout	Baudrate: ▼	
	IP CFG	
Network Status: Ready		

- Return to the **Settings** menu and go to **Manufacturer Settings**.

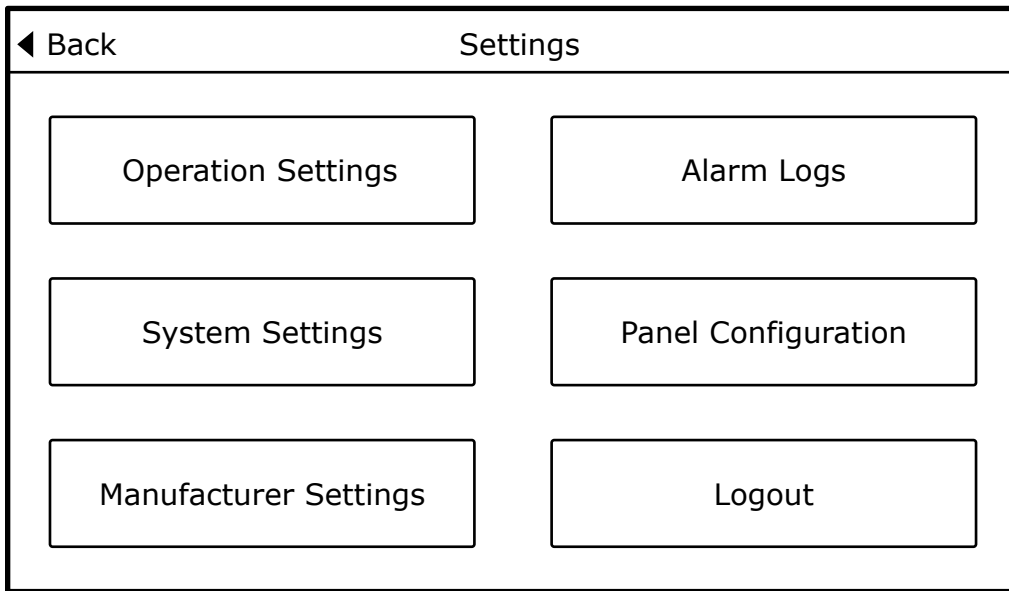

- Go to the **Hardware Configuration** tab and scroll down to **Ethernet1**.
- Update the **Ethernet1** address to match the first three octets of the new **BACnet IP Address** from **Step 1**. The fourth octet should remain "012." In this example, the third octet will update from "000" to "001."

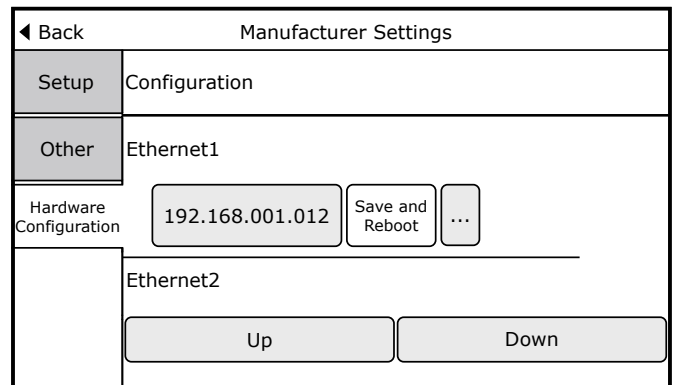
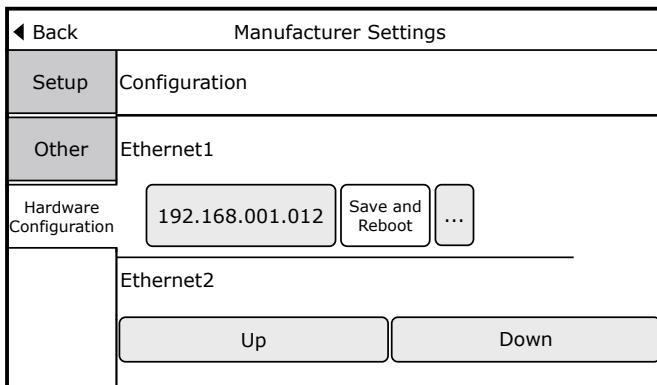

- If the **Subnet Mask** or **Default Gateway** were updated, select the **ellipses icon ("...")** and update these settings to match the changes made to the **Advanced Network Settings** in **Step 1**.
- Once all changes are made, select **Save and Reboot**.

- Once the HMI has restarted, select the **Settings** icon and log in with the **Advanced User Account**.

Username:	QPAC	New Password: _____
Password:	369	

- Go to **System Settings** and open the **Network Settings** tab.
- Confirm that the updates were successful. The **BACnet IP Address** should match the changes made in **Advanced Network Settings** in **Step 1**.
- If any updates were made to the **Subnet Mask** or **Default Gateway**, verify the changes by selecting the **IP CFG** icon to access **Advanced Network Settings**.

◀ Back		System Settings	
Network Settings	BACnet Comm. Mode:	<input type="text" value="IP"/>	
Fireman Override	BACnet Instance:	<input type="text" value="77077"/>	
	BACnet IP Address:	192.168. 1. 25	
Interlock			
Fan Layout	<input type="text" value="IP CFG"/>		
Network Status: Ready			

◀ Back		Advanced Network Settings: Ethernet	
BACnet IP Address Current		BACnet IP Address New	
<input type="text" value="192"/>	<input type="text" value="168"/>	<input type="text" value="1"/>	<input type="text" value="25"/>
BACnet IP Subnet Mask Current		BACnet IP Subnet Mask New	
<input type="text" value="255"/>	<input type="text" value="255"/>	<input type="text" value="255"/>	<input type="text" value="0"/>
BACnet IP DFLT GW Current		BACnet IP DFLT GW New	
<input type="text" value="0"/>	<input type="text" value="0"/>	<input type="text" value="0"/>	<input type="text" value="0"/>
<input type="text" value="Save"/>		<input type="text" value="Reboot"/>	

13. After confirming changes, return to **Settings** and **Logout**. If addition panel configurations are intended, log in with the **User Account (Page 58)**.

Username: ADMIN
Password: 0000

New Password: _____

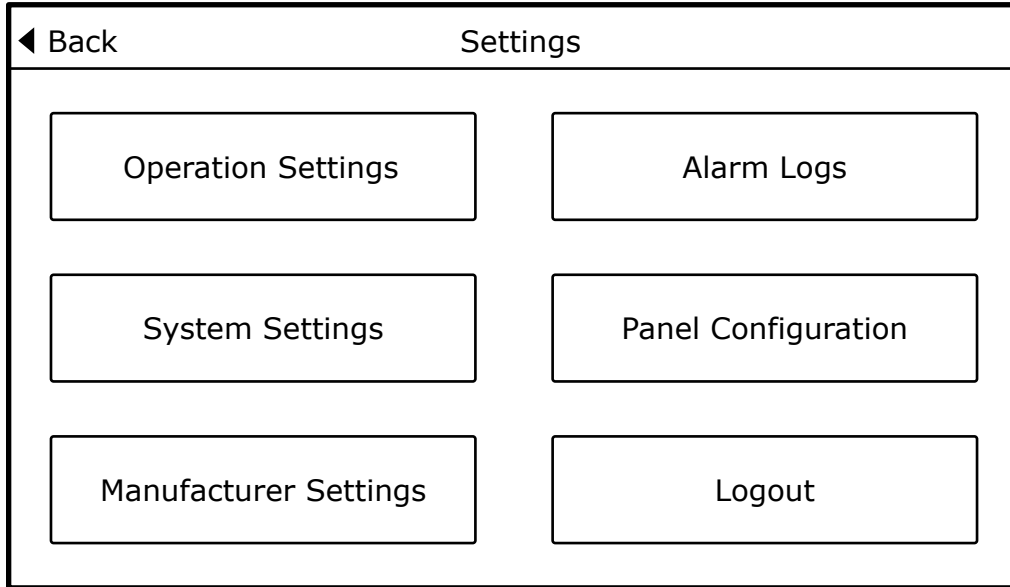

The BACnet/IP Address can also be checked from the Network screen, without needing to login.

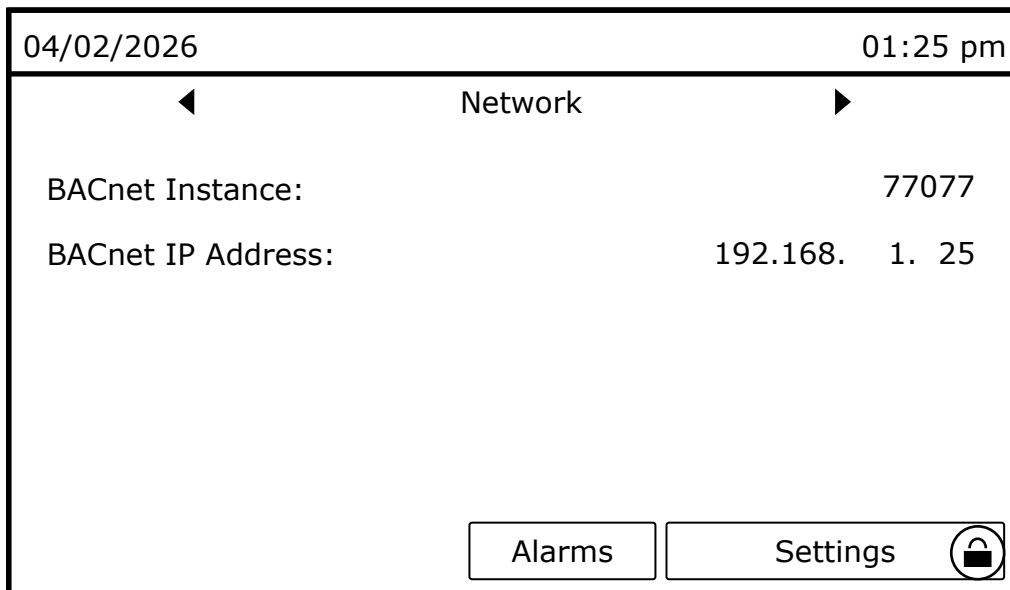

FIREMAN OVERRIDE

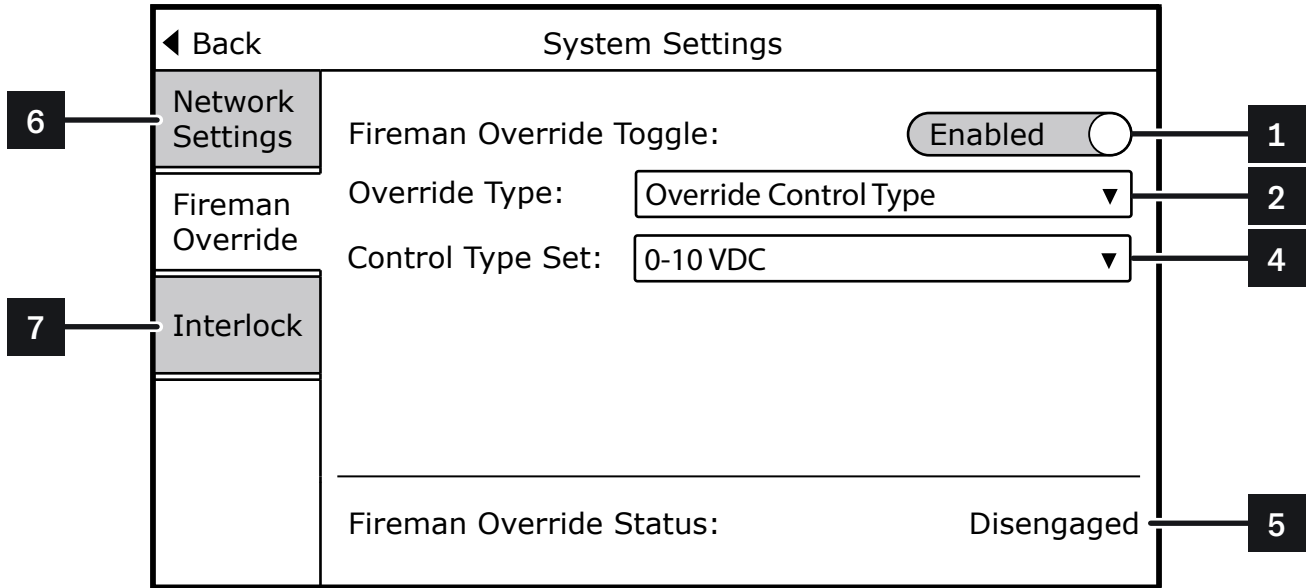

Adjust the Fireman Override settings as desired for operation.



Fireman Override is overridden when **HOA Switch** is set to **Hand** mode.

		<u>Options</u>	<u>Description</u>	<u>Default</u>
1	FIREMAN OVERRIDE TOGGLE	Enabled Disabled	Enable or disable Fireman Override feature.	Disabled
2	OVERRIDE TYPE	Shut Down Set Speed Normal Operation Override Control Type	System set to 0% modulation (no airflow). System modulation set to Set Speed (4) System will operate normally; status will indicate Fireman Override has been engaged. System speed will be dictated by the selected Control Type.	Shut Down
3	SET SPEED	0-100%		0%
4	CONTROL TYPE SET	0-10 VDC Constant Airflow Constant Static Pressure BACnet	See Page 62 for information on Control Types .	0-10 VDC
5	FIREMAN OVERRIDE STATUS	Disabled Engaged Disengaged	Override feature is disabled. Override feature is enabled and active. Override feature is enabled but not active.	
6	NETWORK SETTINGS		See Page 66 .	
7	INTERLOCK		See Page 76 .	

◀ Back System Settings

Network Settings	Fireman Override Toggle:	<input type="radio"/> Disabled	1
Fireman Override			
Interlock			
	Fireman Override Status:	Disabled	5

◀ Back System Settings

Network Settings	Fireman Override Toggle:	<input checked="" type="radio"/> Enabled	1
Fireman Override	Override Type:	Set Speed	2
	Set Speed	0	3
Interlock			
	Fireman Override Status:	Disengaged	5

◀ Back System Settings

Network Settings	Fireman Override Toggle:	<input checked="" type="radio"/> Enabled	1
Fireman Override	Override Type:	Shut Off	2
Interlock			
	Fireman Override Status:	Disengaged	5

INTERLOCK SETTINGS

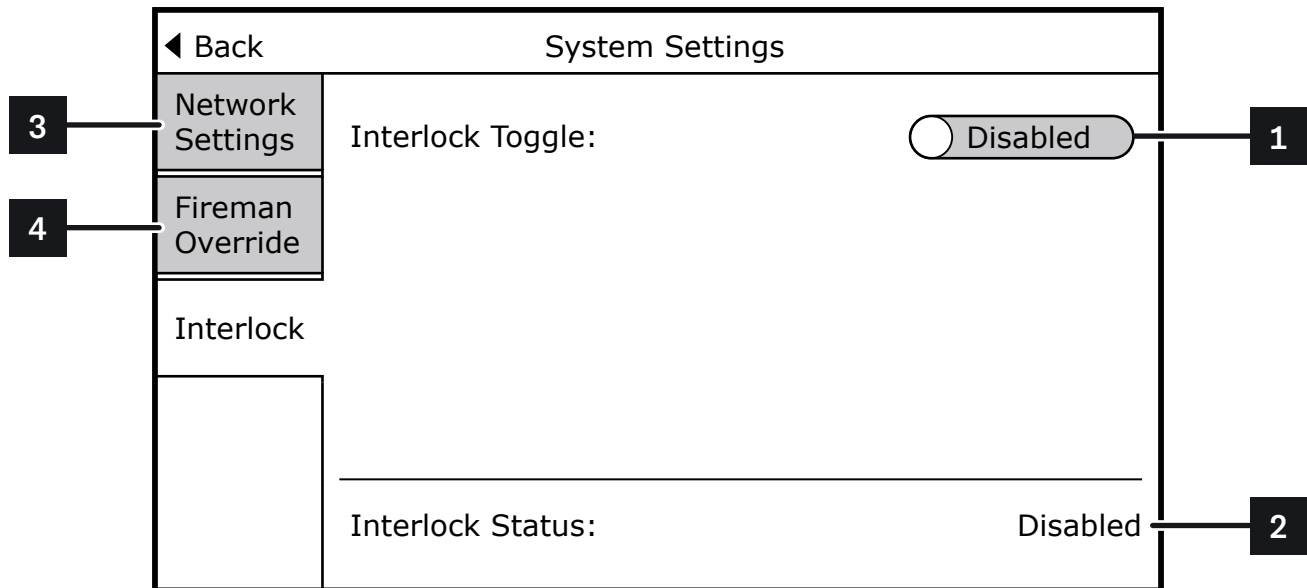

Adjust the Interlock toggle as desired for operation.

		<u>Options</u>	<u>Description</u>	<u>Default</u>
1	INTERLOCK TOGGLE	Enabled Disabled	Enable or disable Interlock feature. Also available through BACnet object Binary Value 2 .	Disabled
2	INTERLOCK STATUS	Disabled Engaged Disengaged	Current state of the override feature. Also available through BACnet object Multistate Input 0 . Interlock feature is disabled. Interlock feature is enabled and active. Interlock feature is enabled but not active.	
3	NETWORK SETTINGS		See Page 66 .	
4	FIREMAN OVERRIDE		See Page 74 .	

FAN LAYOUT SETTINGS

This menu is typically hidden and is only used on systems configured to operate with fewer motorized impellers than the fan's maximum capacity. In these applications, one or more fan locations may be intentionally left uninstalled and covered with blank-off plates. The Fan Controller must be configured to identify which locations contain installed motors and which do not. If this configuration is not updated, or if incorrect locations are selected, the controller will interpret any uninstalled position as a motor failure and generate an alarm.

Access to Fan Layout settings is controlled by a toggle within Manufacturer Settings. This toggle is only available when logged in with a **Q-PAC Service Account (Page 58)**. To access Fan Layout settings, contact **Q-PAC Support** at **904-863-5300** or **Support@q-pac.com**.

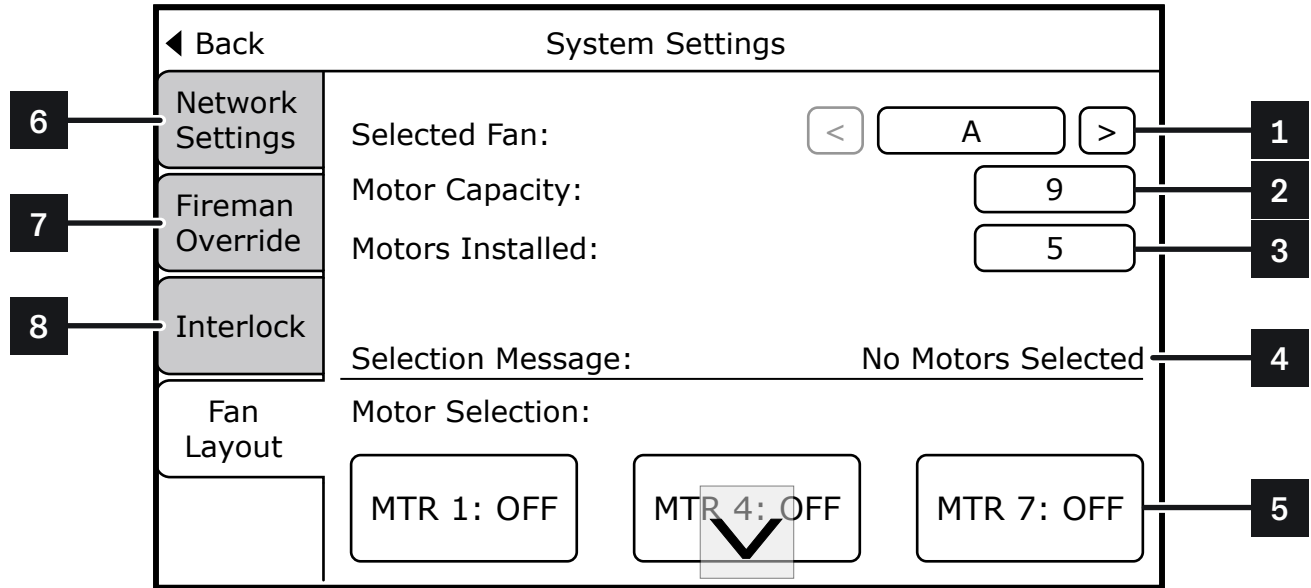

	<u>Options</u>	<u>Description</u>	<u>Default</u>
1	SELECTED FAN A - D	Select the Q-PAC Fan to be managed.	A
2	MOTOR CAPACITY 1 - 9	Maximum number of motorized impellers that can be installed; factory-set.	-
3	MOTORS INSTALLED 1 - Motor Capacity	Total number of motorized impellers installed.	-
4	SELECTION MESSAGE	No Motors Selected Selection Not Complete Selection Complete	No motors are set to active. Number of motors "ON" does not match Motors Installed . Number of motors "ON" matches Motors Installed .
5	MOTOR SELECTION	Selection of motor locations which have a motor installed, typically sequential.	
6	NETWORK SETTINGS	See Page 66 .	
7	FIREMAN OVERRIDE	See Page 74 .	
8	INTERLOCK	See Page 76 .	

ADJUSTING FAN LAYOUT SETTINGS

1. Set the **Selected Fan** [1]. For systems of only one fan, this option is fixed. For systems of multiple Q-PAC Fans, toggle between fans to select the desired fan. Each fan is labeled A to D, as indicated on the Fan Controller.
2. Set the number of **Motors Installed** [3]. This indicates the number of motorized impellers mounted to the fan frame. The **Motor Capacity** [2] represents the maximum number of motors supported by the individual fan. This value is based on the physical design of the fan and is set by the factory.
3. Select the individual motors corresponding to the labeled locations on the Q-PAC Fan. All motor locations will initially be set to "OFF." Upon tapping each motor label, the label will turn green and the status will change to "ON." Once the number of **Motors Installed** is reached, all remaining motor locations will be inactive (grayed out). If the wrong motor is selected, tap it again to toggle it back to "OFF" and select the correct motor.
4. If there are multiple Q-PAC Fans in the system, repeat steps 1 - 3 for each fan.

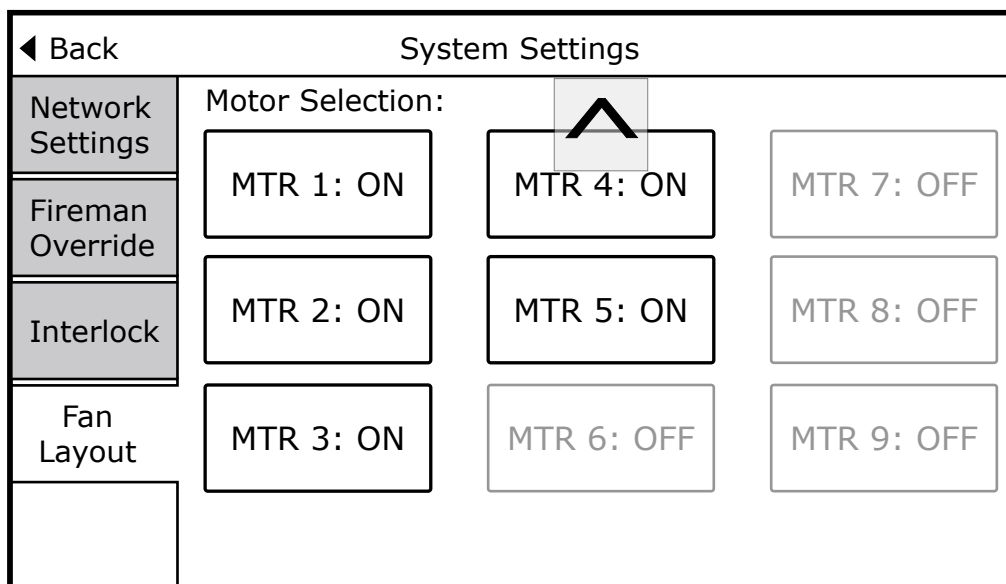
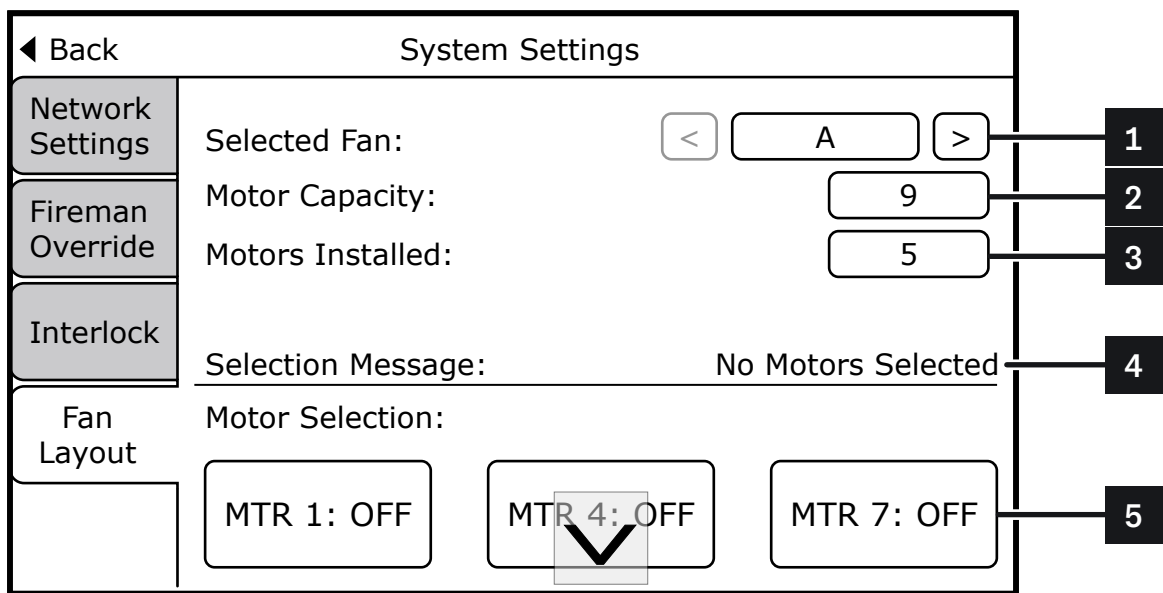

EXAMPLE

The Q-PAC Fan below has a **Motor Capacity** of six (6) motors and five (5) motors are **Installed**. This would result in five (5) motors selected ("ON") and one motor "OFF." Based on the location of the blank-off plate, the selected motors would be:

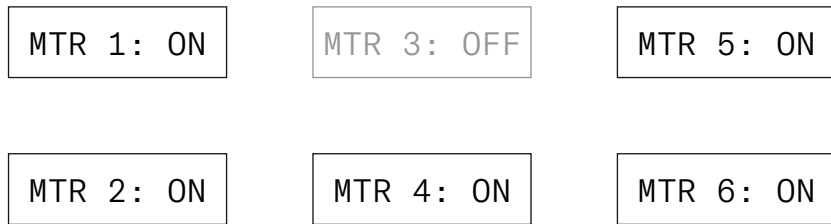

The image below showcases the plug fan mounting locations. Each location is labeled above and below (on the harness) for traceability at the Fan Controller and to aid in any necessary troubleshooting.

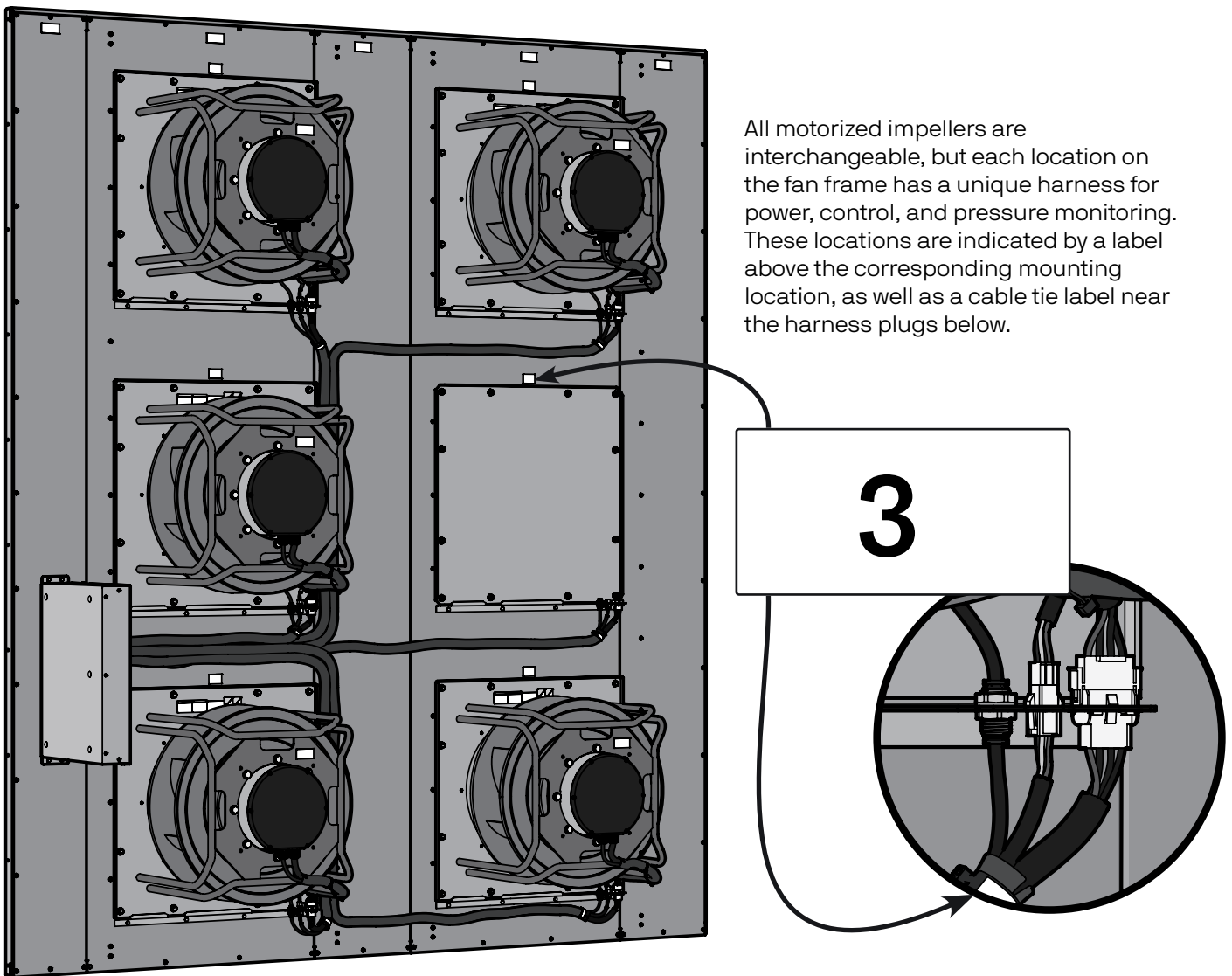

ALARMS AND EVENTS

OVERVIEW

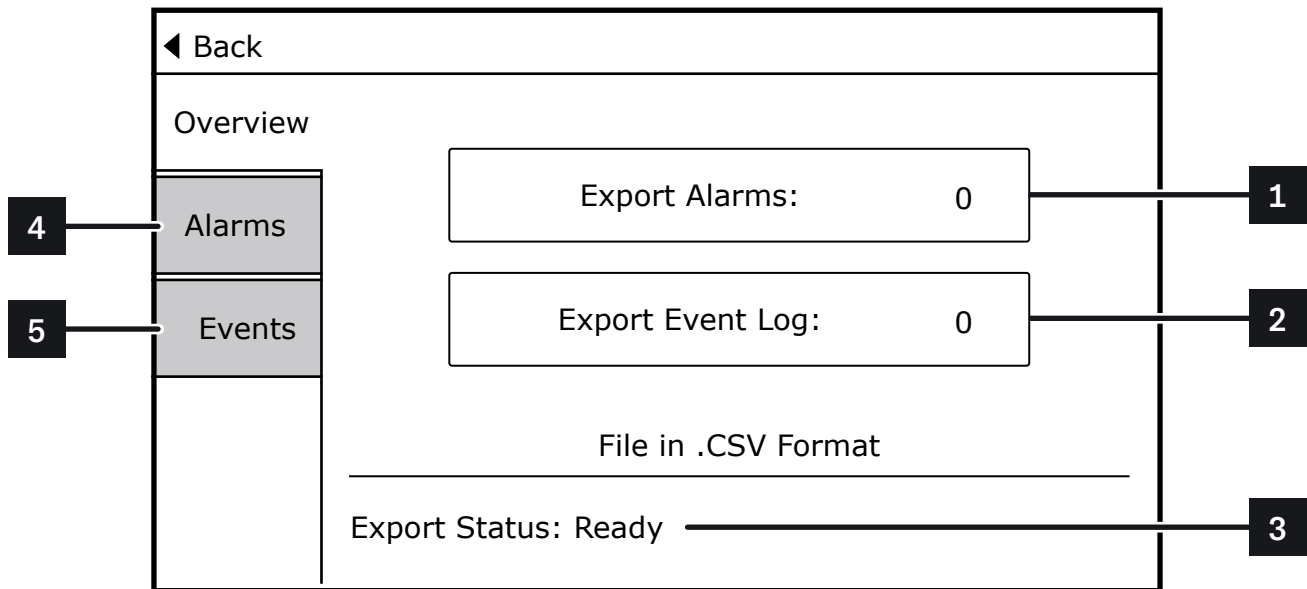

	<u>Options</u>	<u>Description</u>	
1	EXPORT ALARMS	Export Alarms to a .CSV file. The HMI features a port for USB type A, located inside the Control Panel.	
2	EXPORT EVENT LOG	Export Events Log to a .CSV file. The HMI features a port for USB type A, located inside the Control Panel.	
3	EXPORT STATUS	<p>Ready</p> <p>Exporting...</p> <p>Export Complete</p> <p>Insert Storage Device</p> <p>Not Enough Storage</p> <p>File Open/Write Error</p>	<p>Export is ready.</p> <p>Initiating export process.</p> <p>Export process completed.</p> <p>Export failed; no storage device detected in the USB port.</p> <p>Export failed; not enough storage space on the USB drive.</p> <p>Export failed; file may be in use.</p>
4	ALARMS	See Page 81 .	
5	EVENTS	See Page 84 .	

ALARMS

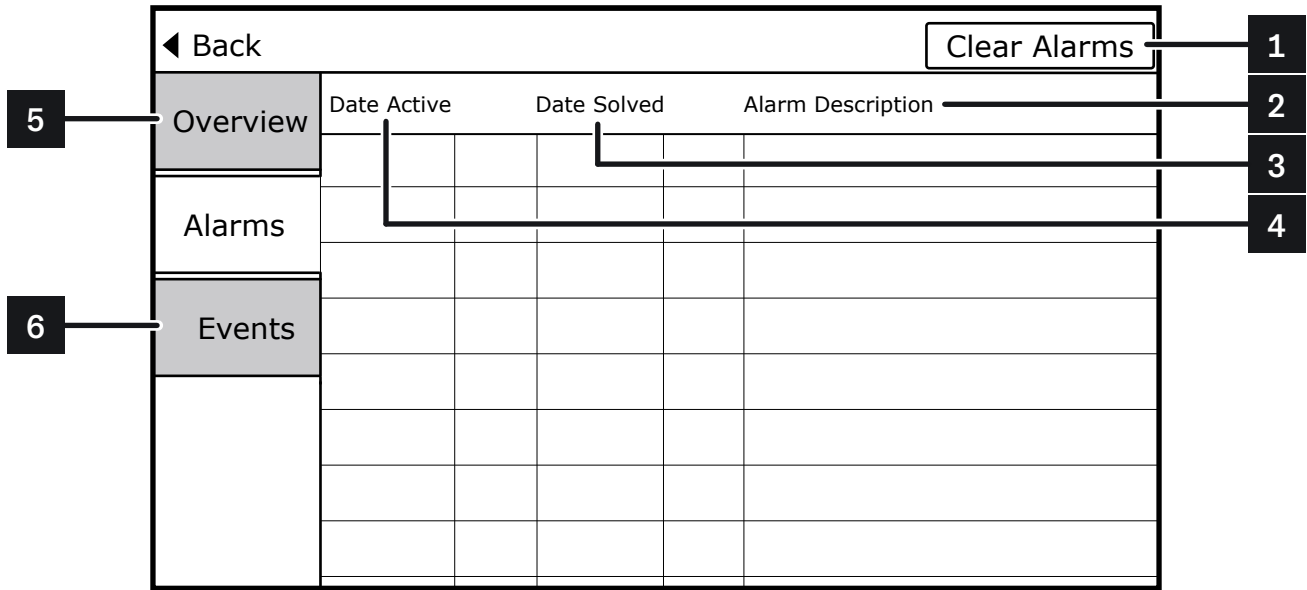

Description

1	CLEAR ALARMS	Clear history of alarms. Requires User Account access (Page 58). This button is not accessible while any alarms are active/unresolved. See Page 85 .
2	DATE ACTIVE	Date and time alarm was activated.
3	DATE SOLVED	Date and time alarm was resolved.
4	ALARM DESCRIPTION	See Page 83 for list of possible alarms.
5	OVERVIEW	See Page 80 .
6	EVENTS	See Page 84 .

ACTIVE ALARM

In the case of an active alarm, the **Home Screen** will display a blinking RED indicator [1] over the **Alarms button** indicating the presence and number of active alarms. The HMI will also produce a loud, continuous tone until the **Alarms Screen** has been accessed (either from the **Home Screen** or **Settings Menu**).

If the event triggering the alarm is no longer true, the alarm will self-resolve. The occurrence of the alarm will still display in the **Alarms Screen** [2].

The screenshot shows the Home Screen with the following information:

- Date: 04/02/2026
- Time: 01:25 pm
- Home button with left and right arrows
- System Status: OK
- Control Type: 0-10 V
- Start/Stop Position: Start
- Modulation: 0%
- Airflow: 0 CFM
- HMI:V 1 . 3 . 0
- PLC:V 4 . 4 . 0
- Alarms button with a red indicator (1)
- Settings button with a lock icon

The screenshot shows the Alarms Screen with the following information:

- Back button
- Clear Alarms button
- Table with columns: Date Active, Date Solved, Alarm Description
- Table content:

Overview	Date Active	Date Solved	Alarm Description
	03/15/2026	13:20	Code 1000: Safety Circuit
Alarms			
Events			

ALARM CODES

		<u>Description</u>
1000	SAFETY CIRCUIT OPEN	Connection of DI1 to 24V terminal has been lost, causing a system shutdown as a safety precaution. Review the safety circuit and/or place a jumper between DI1 and 24V if no safety circuit is present.
1001	POWER METER LOST COMMUNICATION	Power meter has lost power or is experiencing Modbus communication issues with the PLC.
1002	SUPPLY VOLTAGE OUTSIDE RECOMMENDED RANGE	Supply voltage is outside of range required for normal operation. 480V System: 432V to 538V 208/230V System: 187.2V to 260V
1003	CURRENT DRAW OUTSIDE OF RECOMMENDED RANGE	Supply current is outside of the +/- 5% range of system FLA required for normal operation.
1004	MOTORS UNRESPONSIVE TO SPEED MODULATION	Airflow is not being measured. Contact Q-PAC Support for assistance.
1005	MANUFACTURER SETTINGS INCORRECT	Manufacturer Settings have been reset. Contact Q-PAC Support at for assistance.
2000	Q-PAC FAN A MOTOR(S) AT FAULT	
2001	Q-PAC FAN B MOTOR(S) AT FAULT	One or more motors of the indicated Q-PAC Fan are not functional. Check the Q-PAC Fan Motor Status screen for the indicated Q-PAC Fan to identify motors at fault. See Page 90 .
2002	Q-PAC FAN C MOTOR(S) AT FAULT	
2003	Q-PAC FAN D MOTOR(S) AT FAULT	
2009	Q-PAC FAN A PCB LOST POWER. 0-10V SPEED MOD STILL OPERABLE.	
2010	Q-PAC FAN B PCB LOST POWER. 0-10V SPEED MOD STILL OPERABLE.	The microcontroller of the indicated Q-PAC Fan has lost power. Check power supply and field wiring. See Pages 32-37 .
2011	Q-PAC FAN C PCB LOST POWER. 0-10V SPEED MOD STILL OPERABLE.	
2012	Q-PAC FAN D PCB LOST POWER. 0-10V SPEED MOD STILL OPERABLE.	

EVENTS

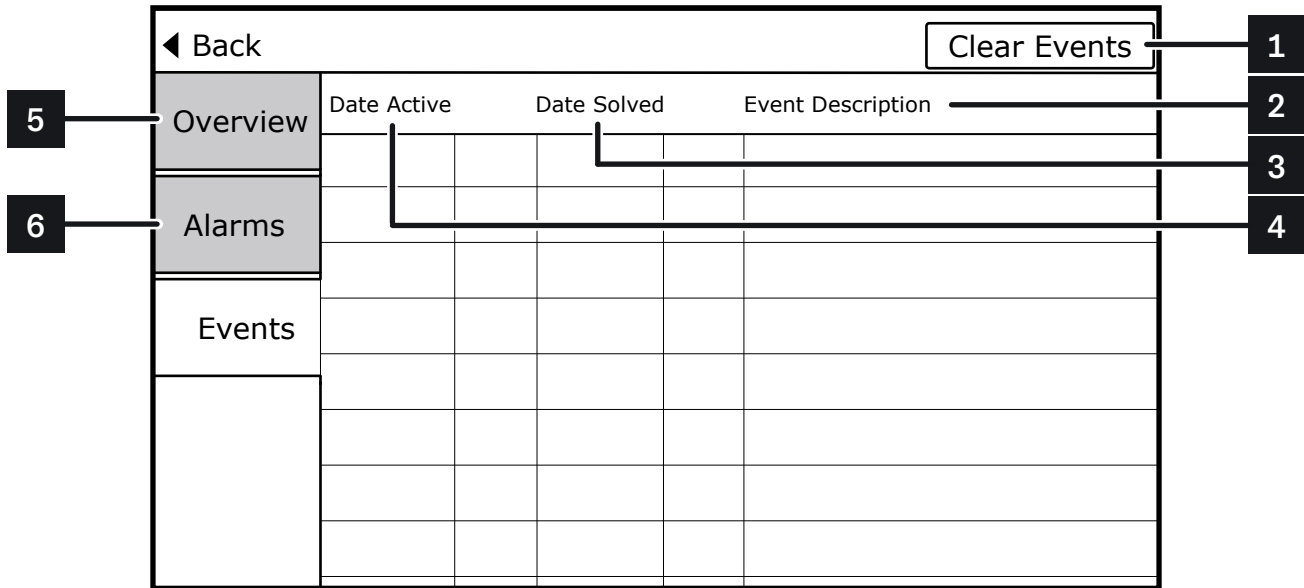

Description

1	CLEAR EVENTS	Clear history of alarms. Requires User Account access. This button is not accessible while any alarms are active/unresolved. See Page 85 .
2	DATE ACTIVE	Date and time event was triggered.
3	DATE SOLVED	Date and time event was resolved.
4	EVENT DESCRIPTION	Shows details of modifications to any of the following settings: <ul style="list-style-type: none"> ■ HOA switch position ■ Start/Stop position ■ System running status ■ Control type switch ■ Fireman Override type ■ Fireman Override control type ■ Fan controller temporary power loss (brownout) ■ Fan resonant frequency detection
5	OVERVIEW	See Page 80 .
6	ALARMS	See Page 81 .

CLEAR ALARMS / EVENTS

Clearing Alarms and/or Events will permanently delete the history of alarms and/or events. This button will not be available if there are any active/unresolved alarms.

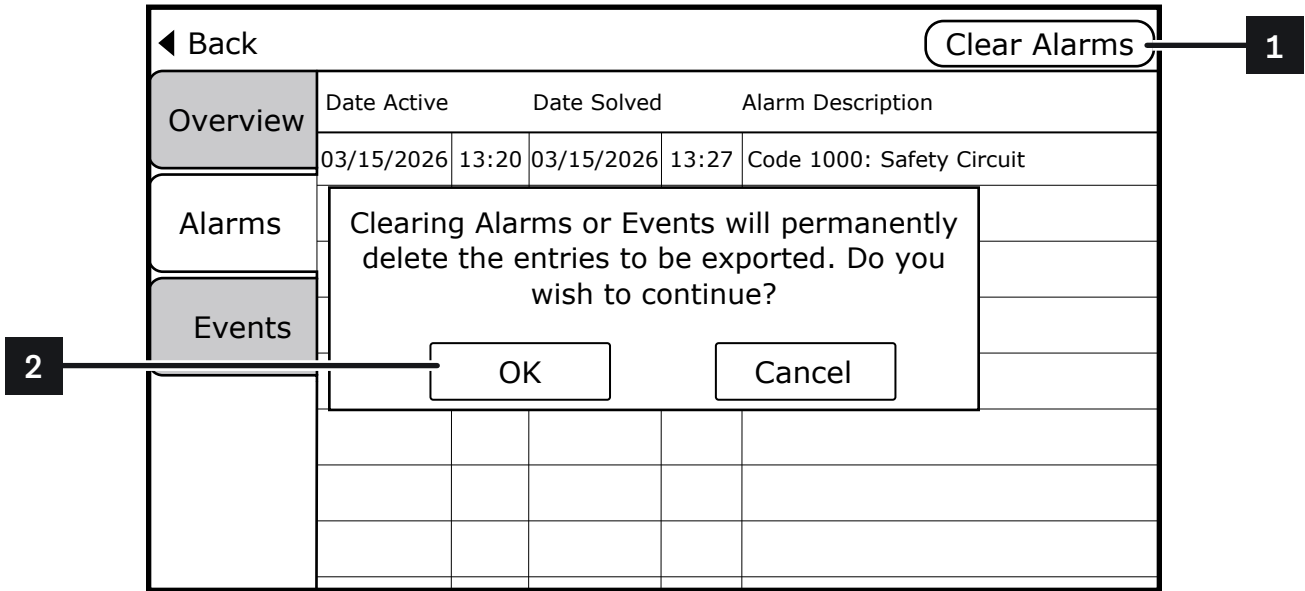

To clear Alarms or Events:

1. Select **Clear Alarms** or **Clear Events** [1] from the upper right corner of the screen.
2. Select **OK** [2] to confirm deletion of alarms/events. If accessing the **Alarms** screen or **Events** screen from the **Home** screen, users will be prompted to log into the **User Account** first.

PANEL CONFIGURATION

DATE AND TIME

		<u>Options</u>	<u>Description</u>
1	DATE		Current date in the format Month / Day / Year.
2	HOUR FORMAT	12 Hour 24 Hour	Set the time format for the Control Panel.
3	TIME		Current time, corresponding to the selected Hour Format.
4	OTHER		See Page 87.

OTHER SETTINGS

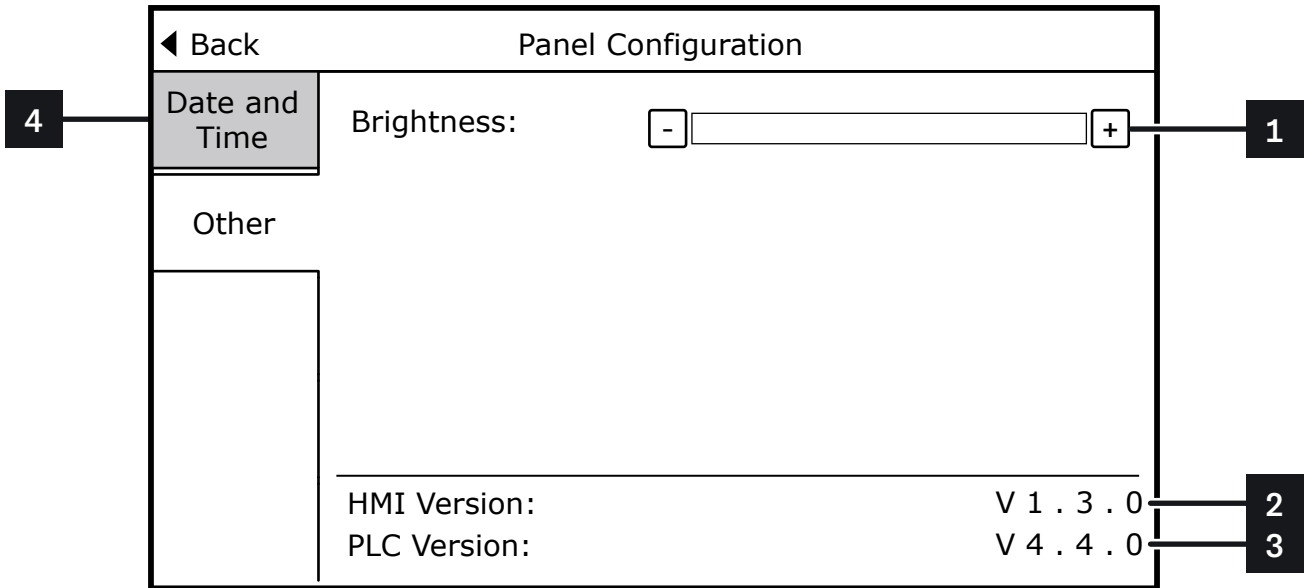

Description

1	BRIGHTNESS	Adjust the display brightness on the HMI.
2	HMI VERSION	Current HMI version.
3	PLC VERSION	Current PLC version.
4	DATE AND TIME	See Page 86 .

STATUS MONITORING

HOME SCREEN

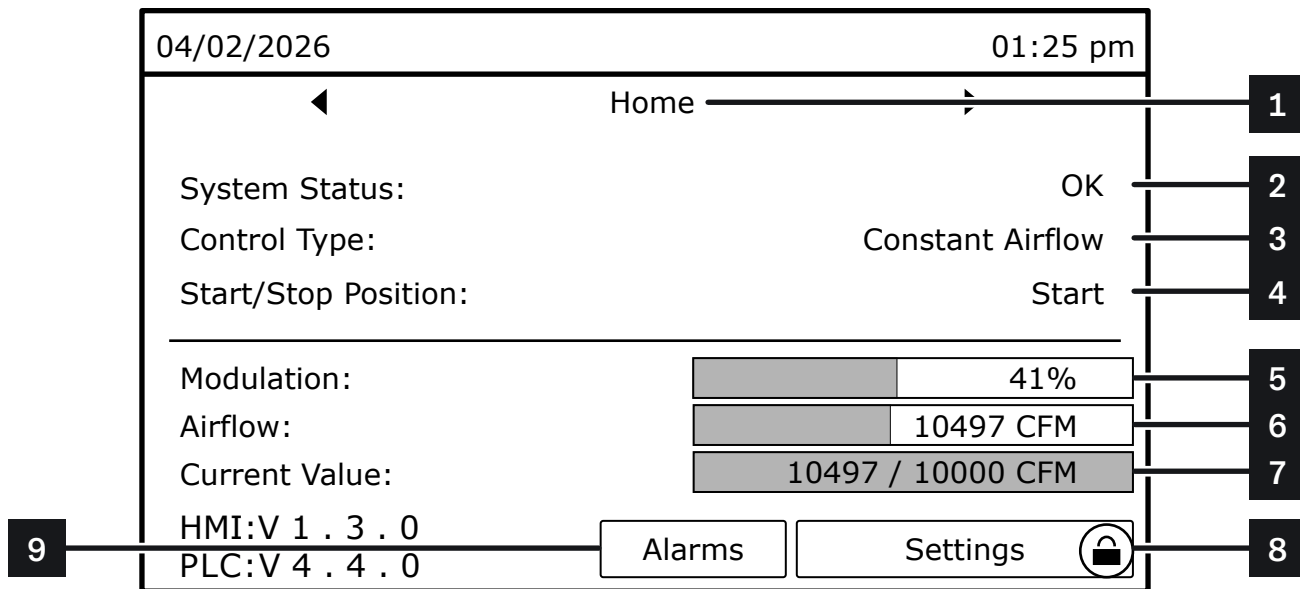

	<u>Options</u>	<u>Description</u>
1	CURRENT SCREEN	Current screen description with left/right scrolling arrows.
2	SYSTEM STATUS	<ul style="list-style-type: none"> Safety Circuit OFF: Safety Circuit is open. HOA switch is turned to OFF position. Hand Mode: HOA switch is turned to HAND position. Fireman Override OFF: Fireman Override is enabled and engaged. Start/Stop is set to STOP. Interlock Override Disabled: Interlock is enabled and engaged. System Run is disabled in Operating settings or BACnet object Binary Value 1. Fan Alarm: Active alarm detecting fault at one or more fans. Control Panel Alarm: Active alarm detecting fault at the Control Panel. OK: System is operational/ready for operation.
3	CONTROL TYPE	Current Control Type (Page 62).
4	START/STOP POSITION	<ul style="list-style-type: none"> Start: Start/Stop status. Stop
5	MODULATION	Modulation based on current Control Type . A blinking modulation has not yet reached minimum speed. A green bar indicates ramp progress is Ramp feature is engaged.
6	AIRFLOW	Calculated system airflow.
7	CURRENT VALUE	See Page 89.
8	SETTINGS	See Page 61 if lock icon present, otherwise see Page 56.
9	ALARMS	See Page 81.



The **Current Value** bar compares the real time calculated airflow or measured static pressure against their corresponding set point. This bar appears only when the **Control Type** is set to **Constant Airflow** or **Constant Static Pressure**.

In order to aid in understanding fan operation, there are three possible cases indicated by this bar:

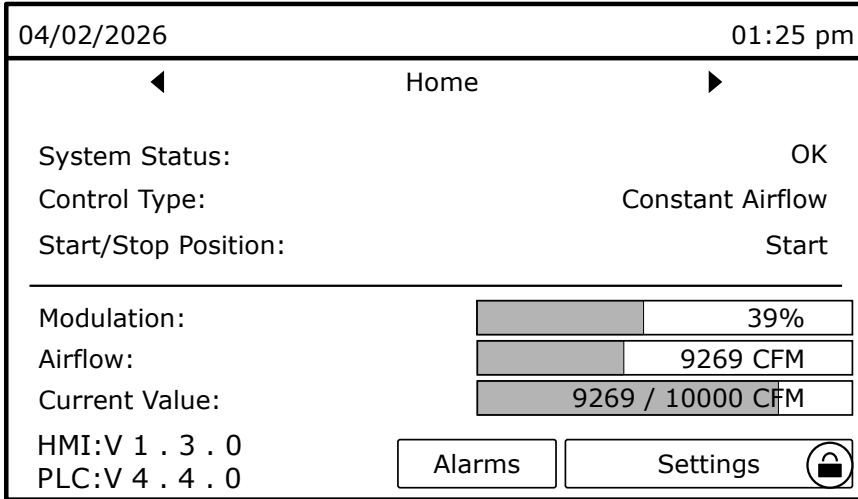

CASE 1

If the real time calculated value has not reached the set point, the **Current Value** bar will be BLUE.

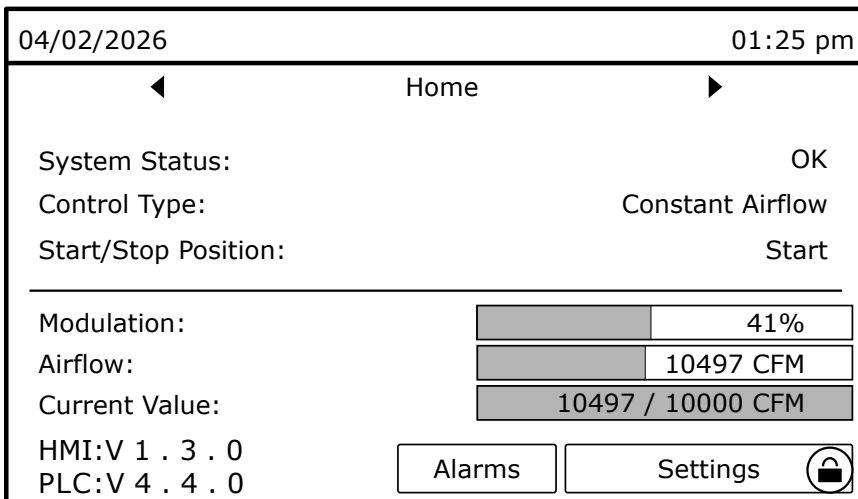

CASE 2

If the real time calculated value has reached the set point, the **Current Value** bar will be GREEN.

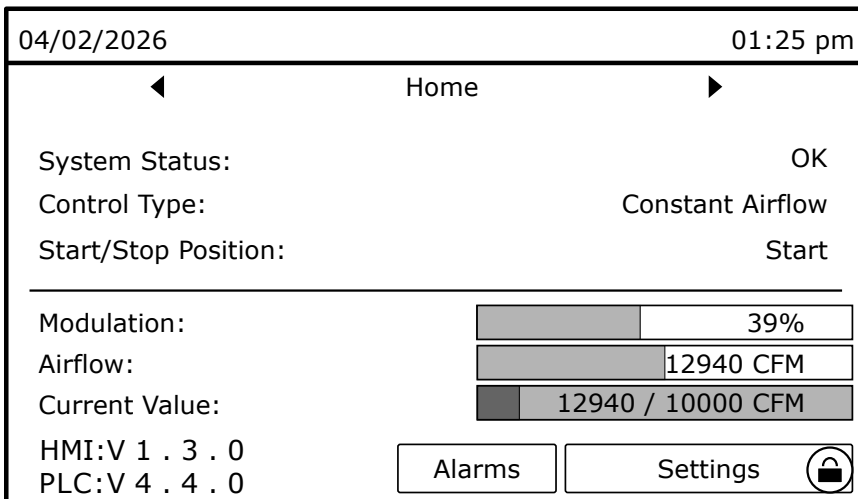

CASE 3

If the real time calculated value has reached and exceed the set point, the **Current Value** bar will be GREEN with a smaller, superimposed RED bar.

Q-PAC FAN STATUS

The format of the Fan Status screen will vary depending on the number of Q-PAC Fans installed in the system. See the following diagrams for variances between systems of one and multiple fans.

SINGLE Q-PAC FAN

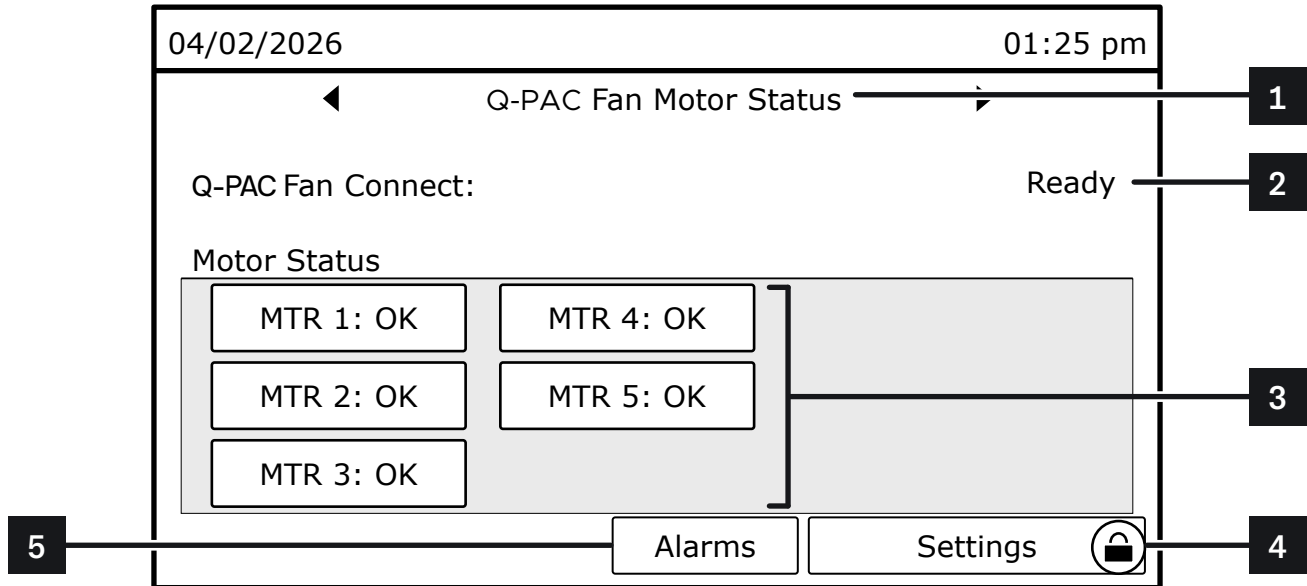

	<u>Options</u>	<u>Description</u>	
1	CURRENT SCREEN	Current screen description with left/right scrolling arrows.	
2	FAN CONTROLLER	Ready Motor(s) at Fault	All connected motors are operational. One or more motors are at fault. Check motor(s) and contact Q-PAC Support if needed.
3	MOTOR STATUS	OK Fault Not Used	Motor is operational. Fault at motor. Check motor and contact Q-PAC Support if needed. Motor not installed/in use.
4	SETTINGS		See Page 61 if lock icon present, otherwise see Page 56 .
5	ALARM		See Page 81 .

MULTIPLE Q-PAC FANS

If the system contains multiple Q-PAC Fans, the screen will instead contain a side tab for each Q-PAC Fan. Fans will be labeled alphabetically, matching the label on each fan's Fan Controller.

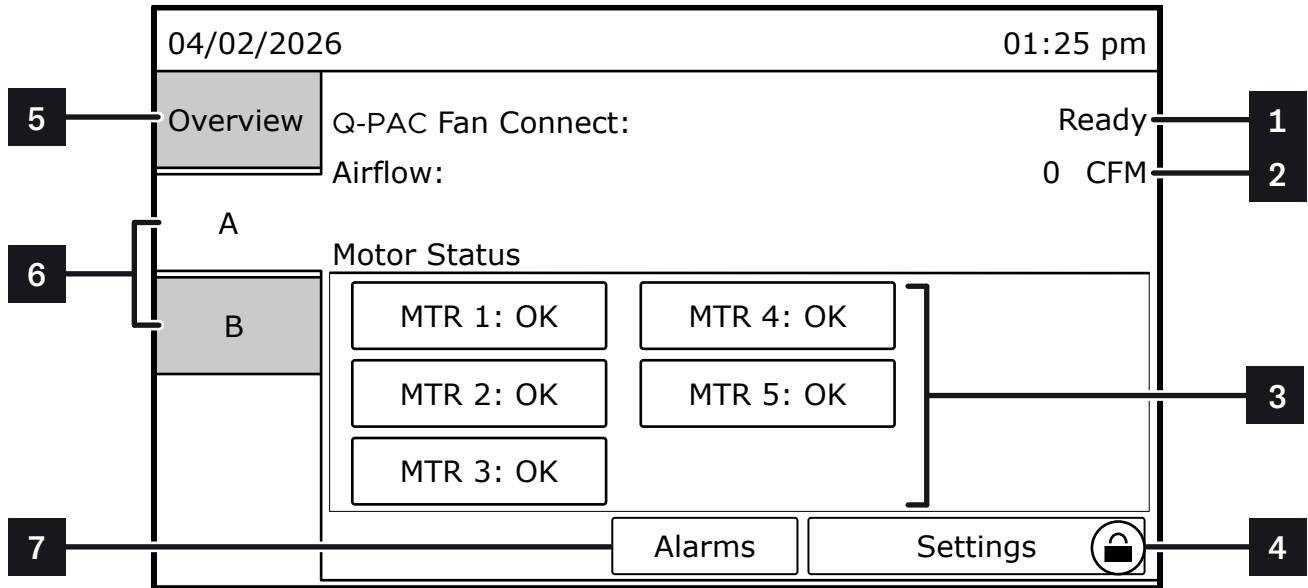

		<u>Options</u>	<u>Description</u>
1	FAN CONTROLLER	Ready Motor(s) at Fault	All connected motors are operational. Q-PAC Support if needed.
2	AIRFLOW		Total calculated airflow from this fan0
3	MOTOR STATUS	OK Fault Not Used	Motor is operational. Fault at motor. Check motor and contact Q-PAC Support if needed. Motor not installed/in use.
4	SETTINGS		See Page 61 if lock icon present, otherwise see Page 56 .
5	OVERVIEW		System-level view, with left/right scrolling arrows.
6	Q-PAC FAN SELECTION		Individual fan monitoring.
7	ALARMS		See Page 81 .

POWER MONITORING

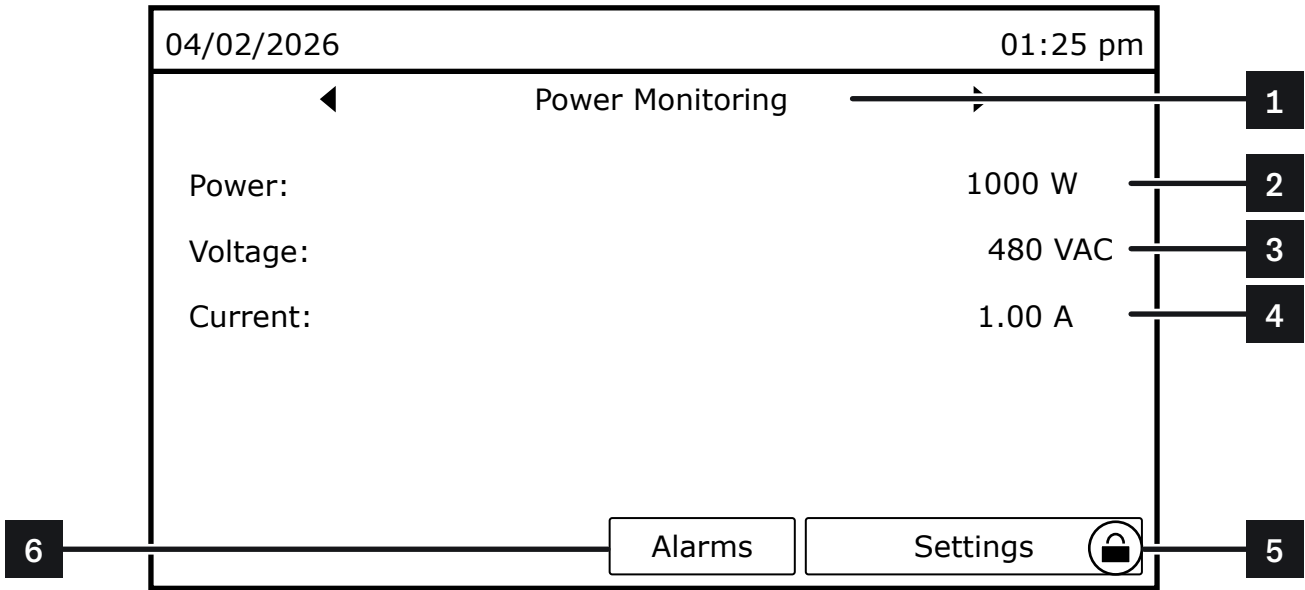

Description

		Description
1	CURRENT SCREEN	Current screen description with left/right scrolling arrows.
2	POWER	System power consumption.
3	VOLTAGE	System voltage.
4	CURRENT	System current draw.
5	SETTINGS	See Page 61 if lock icon present, otherwise see Page 56 .
6	ALARMS	See Page 81 .

NETWORK

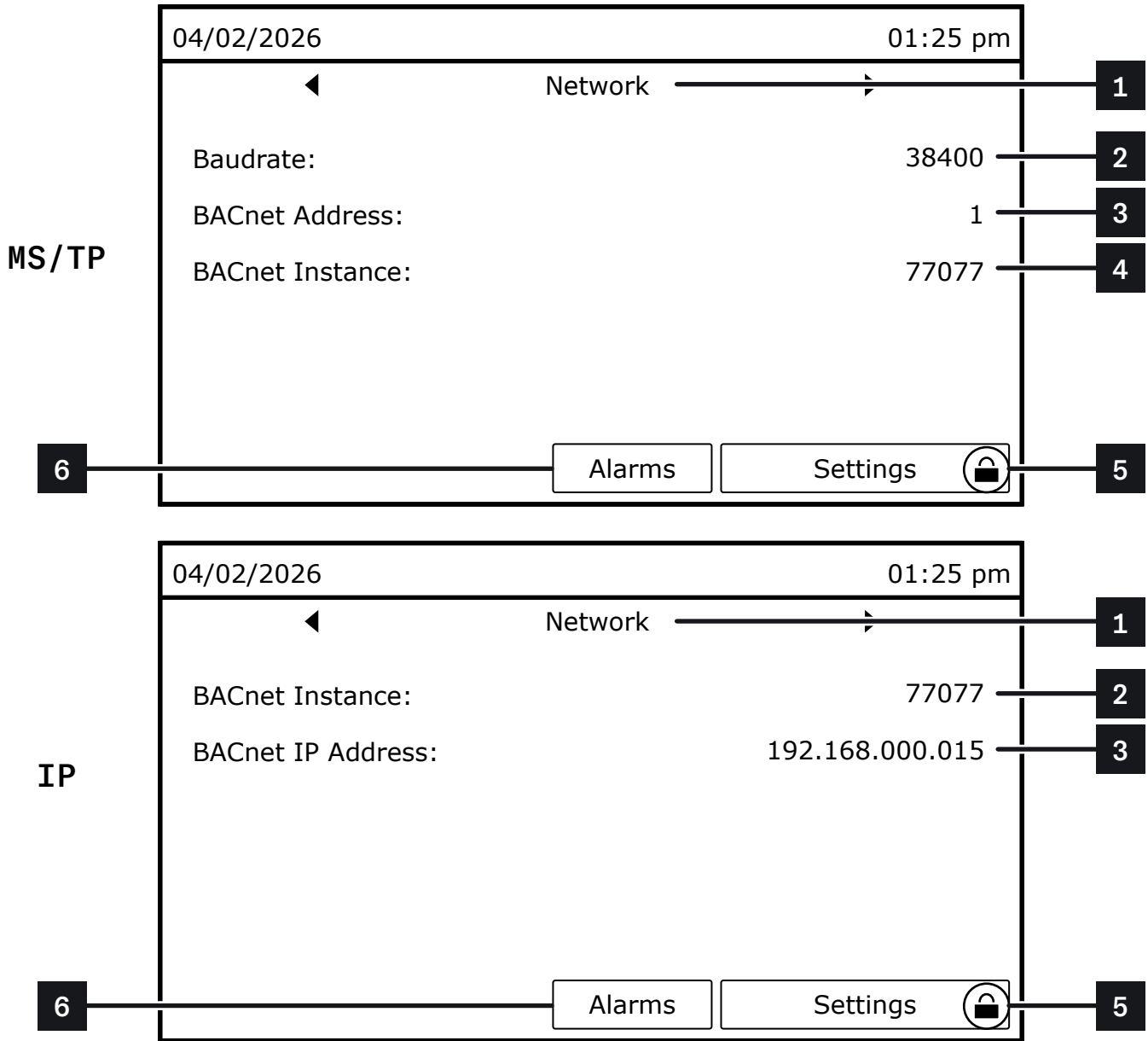

See the **BACnet** section on **Page 46** for more information on configuring the BACnet implementation.

	<u>Description</u>
1	CURRENT SCREEN Current screen description with left/right scrolling arrows.
2	BAUDRATE System Baudrate.
3	BACNET ADDRESS Device address.
4	BACNET INSTANCE Device instance.
5	SETTINGS See Page 61 if lock icon present, otherwise see Page 56 .
6	ALARMS See Page 81 .

RELAY STATUS

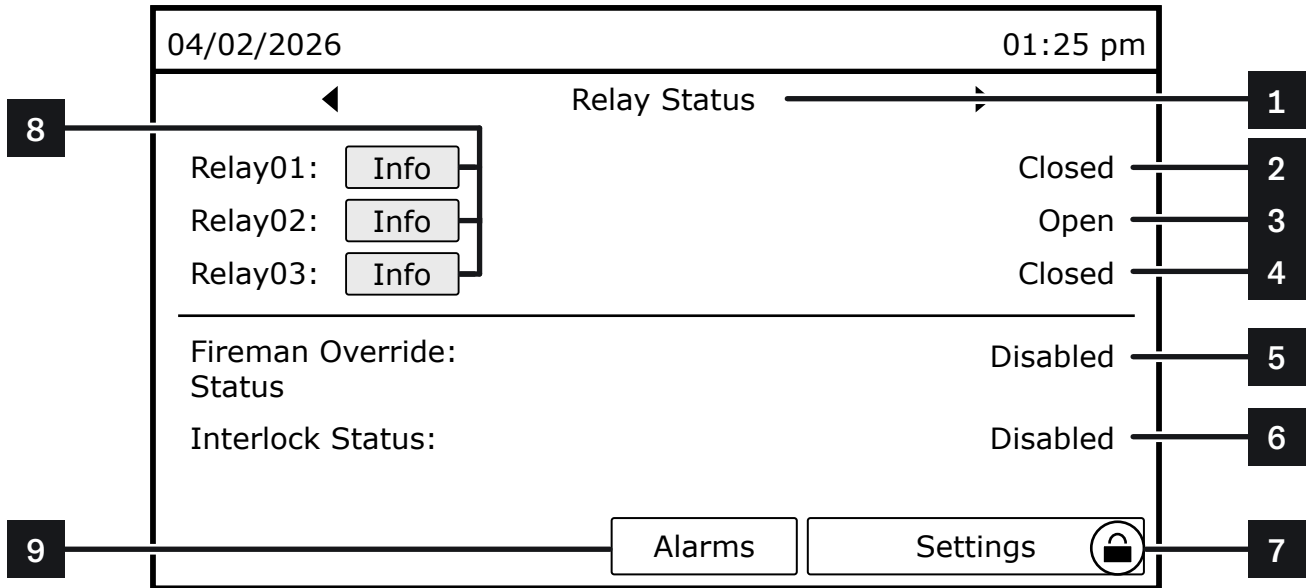

		<u>Options</u>	<u>Description</u>
1	CURRENT SCREEN		Current screen description with left/right scrolling arrows.
2	RELAY01	Open Closed	Relay01 Status. Relay01 signals if the fan is ready for operation. OPEN: Not ready for operation CLOSED: Ready for operation Closed circuit requires that Safety Circuit is CLOSED <u>AND</u> either: <ul style="list-style-type: none"> ■ Start/Stop switch is set to START ■ HOA switch is set to AUTO <u>OR</u> <ul style="list-style-type: none"> ■ HOA switch is set to HAND
3	RELAY02	Open Closed	Relay02 Status. Relay02 closes when the motors of the fan are drawing power and the modulation speed is greater than 10%. OPEN: Fan is not running CLOSED: Fan is running
4	RELAY03	Open Closed	Relay03 Status. Relay03 is a digital output that signals if there is an active alarm. OPEN: Error / alarm CLOSED: No errors / alarms
5	FIREMAN OVERRIDE STATUS		See Page 74 .
6	INTERLOCK STATUS		See Page 76 .
7	SETTINGS		See Page 61 if lock icon present, otherwise see Page 56 .
8	RELAY INFO		Information on the operation of each relay.
9	ALARMS		See Page 81 .

MANUFACTURER SETTINGS

The following information is provided for reference when contacting Q-PAC Support. The following menus are only accessible when logged into the **Advanced User Account** or **Service Account** (Page 58).

The following menus are for use in the rare case in which EEPROM variables of the programmable controller have been reset to their factory settings. All values are configured at the factory prior to shipment. These settings are used to enable access to for the HMI to manage multiple Q-PAC Fans and the number of active motors in each fan. Changes to these settings outside of their factory configuration may also require hardware updates. Do not access or modify these settings without the guidance of Q-PAC Support; their contact information is provided below:

Q-PAC Support
 904-863-5300
 support@q-pac.com

SETUP

The screenshot shows the 'Manufacturer Settings' screen with a left-hand menu and a main configuration area. The left menu has 'Setup' selected, with 'Other' and 'Hardware Configuration' also visible. The main area contains the following settings:

- PT Range:** A dropdown menu currently showing '0-10 "WC'. Callout 1 points to this dropdown.
- Expandable System:** A text input field containing 'No'. Callout 2 points to this field.
- Motor Model:** A text input field containing '17 00078'. Callout 3 points to this field.
- Q-PAC Fan Count:** A row of four buttons labeled '1', '2', '3', and '4'. Callout 4 points to the '3' button.
- Q-PAC Fan A Motor QTY:** A text input field containing '5'. Callout 5 points to this field.
- Q-PAC Fan B Motor QTY:** A text input field containing '0'. Callout 5 points to this field.

Callout 6 points to the 'Other' menu item, and callout 7 points to the 'Hardware Configuration' menu item.

		<u>Options</u>	<u>Description</u>
1	PT RANGE	0 -10 "WC 0 -15 "WC 0 -20 "WC	This setting only applies to older systems, released under version 2. Configure this value based on the range of the pressure transducer within the Fan Controller. Default is 0 -15 "WC.
2	EXPANDABLE SYSTEM	Yes No	Manages access to Fan Layout settings. See Page 77 .
3	MOTOR MODEL		Plug fan assembly model.
4	Q-PAC FAN COUNT	1 -4	Total number of Q-PAC Fans in the system.
5	Q-PAC FAN MOTOR QTY	0 -9	Maximum number of motors supported by the Q-PAC Fan (A-D).
6	OTHER		See Page 96 .
7	HARDWARE CONFIGURATION		See Page 97 .

OTHER SETTINGS

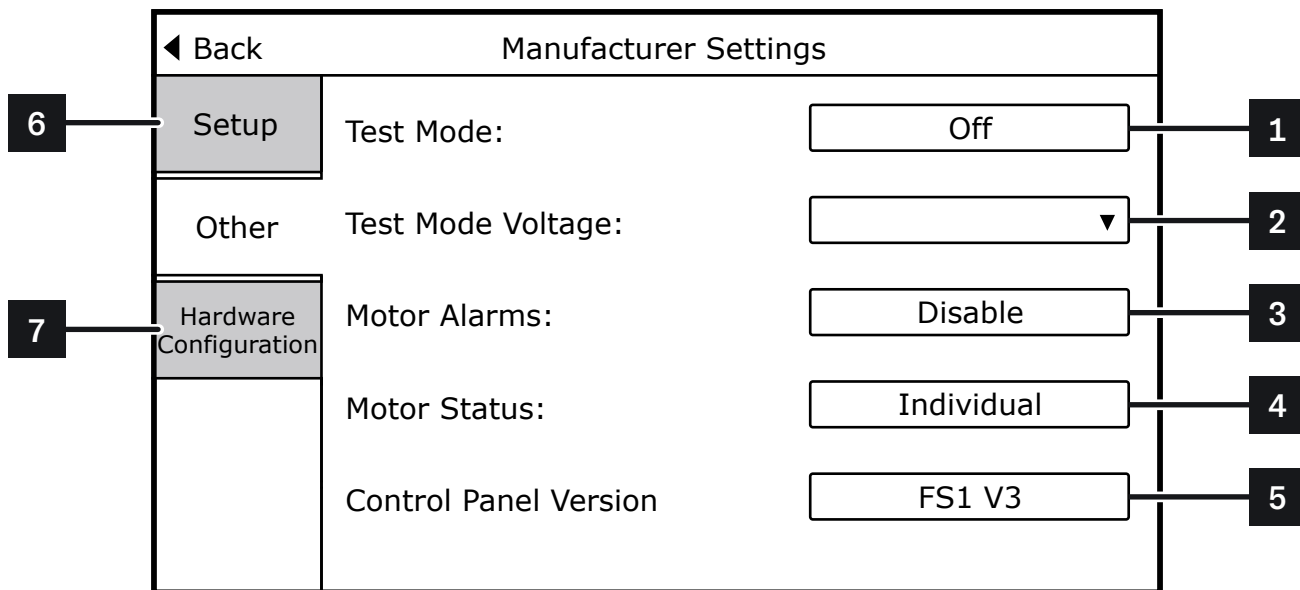

		<u>Options</u>	<u>Description</u>
1	TEST MODE	On Off	Turn "ON" to simulate voltage, current, and power data for the panel. This allows Relay02 to close and voltage/current alarms to clear despite conditions not being met for testing purposes.
2	TEST MODE VOLTAGE	208V 480V 120V	Only applicable when Test Mode is toggled to "ON" position. This allows configuration of the simulated power meter based on supply voltage for the system.
3	MOTOR ALARMS	Enable Disable	Q-PAC Fan Motor Status screen (Page 90) displays status of each motor in the fan. Q-PAC Fan Motor Status screen displays only the status of the fan.
4	MOTOR STATUS	Individual Array	This setting only applies to older systems, released under version 2. This setting allows the user to toggle between returning the status of each motor or the status of the Q-PAC Fan as a singular object. This setting requires hardware modification; contact Q-PAC Support for assistance.
5	CONTROL PANEL VERSION		System version
6	SETUP		See Page 95 .
7	HARDWARE CONFIGURATION		See Page 97 .

HARDWARE CONFIGURATION SETTINGS

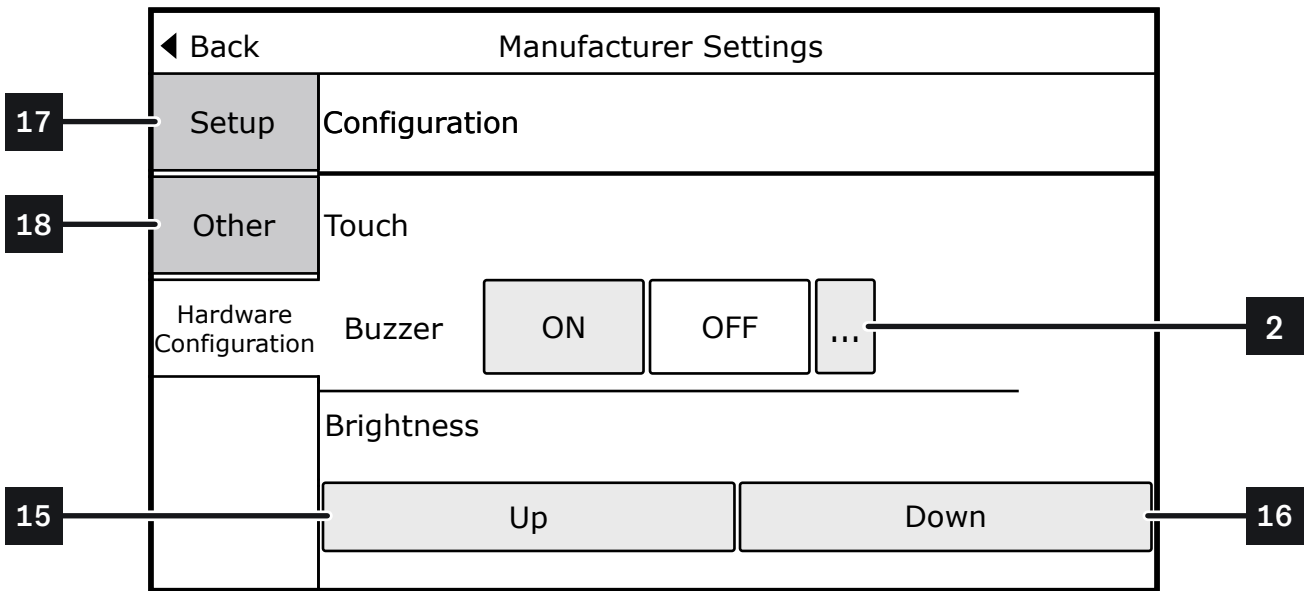
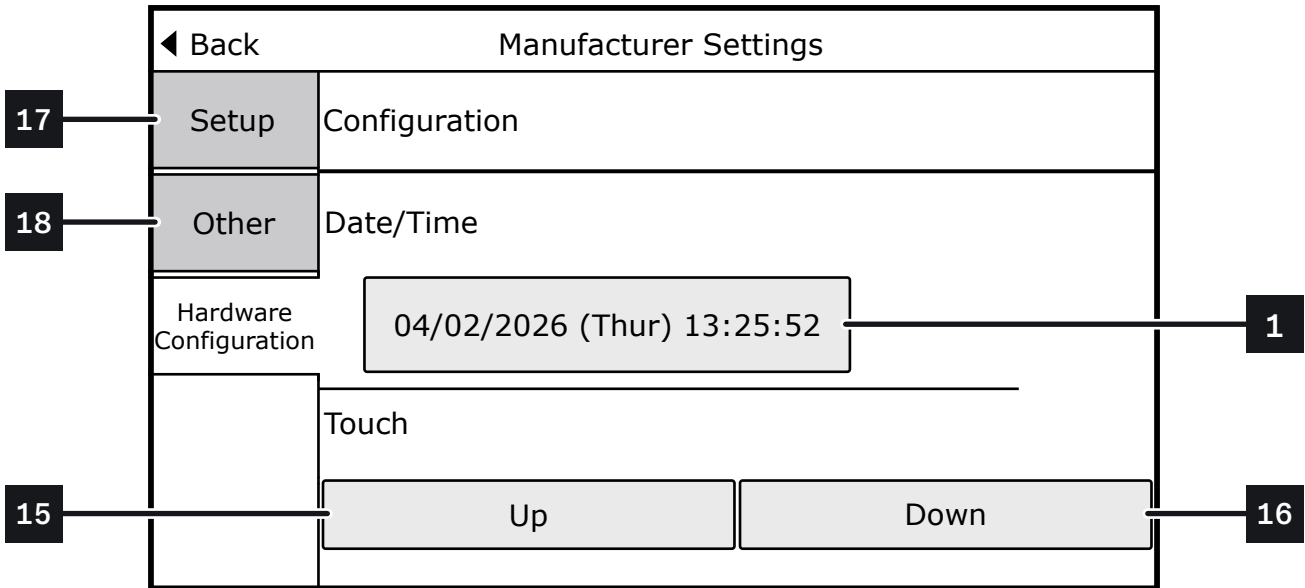

		<u>Options</u>	<u>Description</u>
1	DATE/TIME	MM/DD/YYYY (Day) HH:MM:SS	Configure the date and time settings of the HMI.
2	TOUCH BUZZER	On Off	Turn off auditory feedback with page navigation and alarms.
15	UP		Moves to the previous setting (above).
16	DOWN		Moves to the next setting (below).
17	SETUP		See Page 95 .
18	OTHER		See Page 96 .

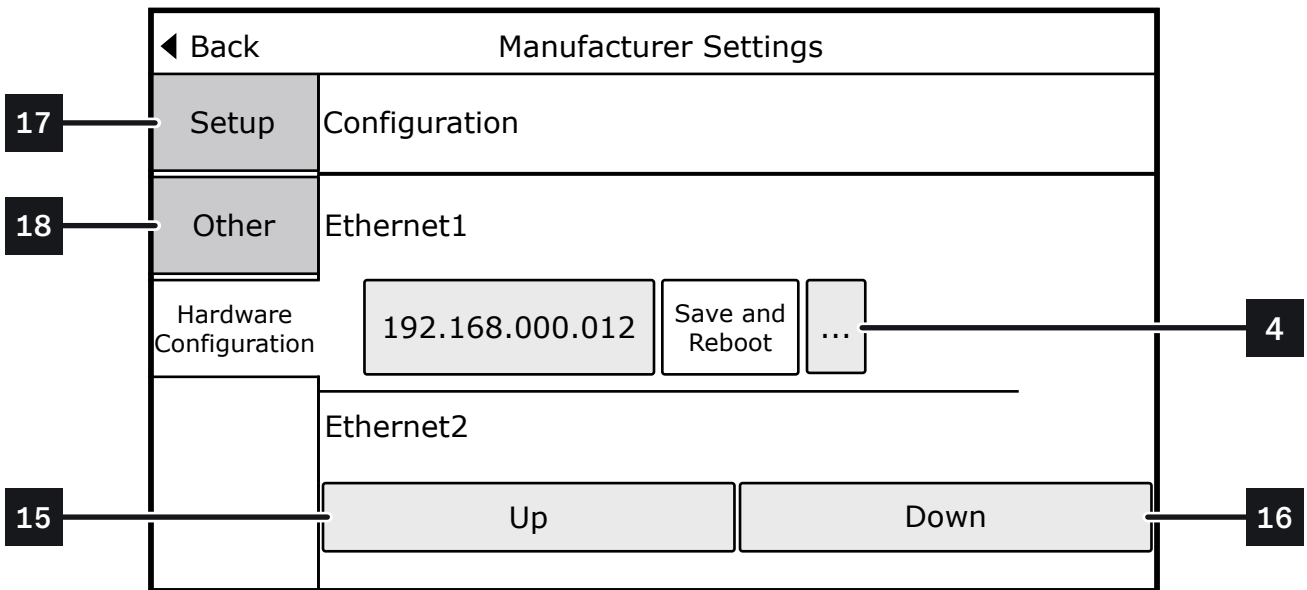
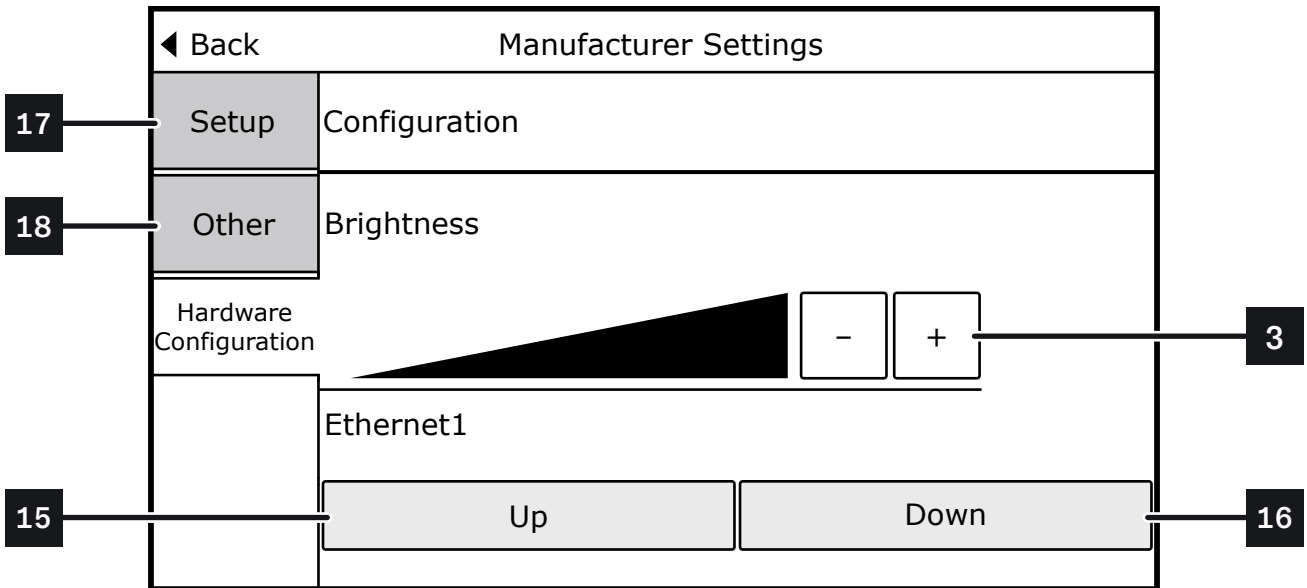

		<u>Options</u>	<u>Description</u>
3	BRIGHTNESS	+ -	Increase or decrease the brightness of the HMI display.
4	ETHERNET1	###.###.###.###	Configure the IP address of Ethernet port 1 of the HMI. This setting should only be modified under the guidance of Q-PAC Support .
15	UP		Moves to the previous setting (above).
16	DOWN		Moves to the next setting (below).
17	SETUP		See Page 95 .
18	OTHER		See Page 96 .

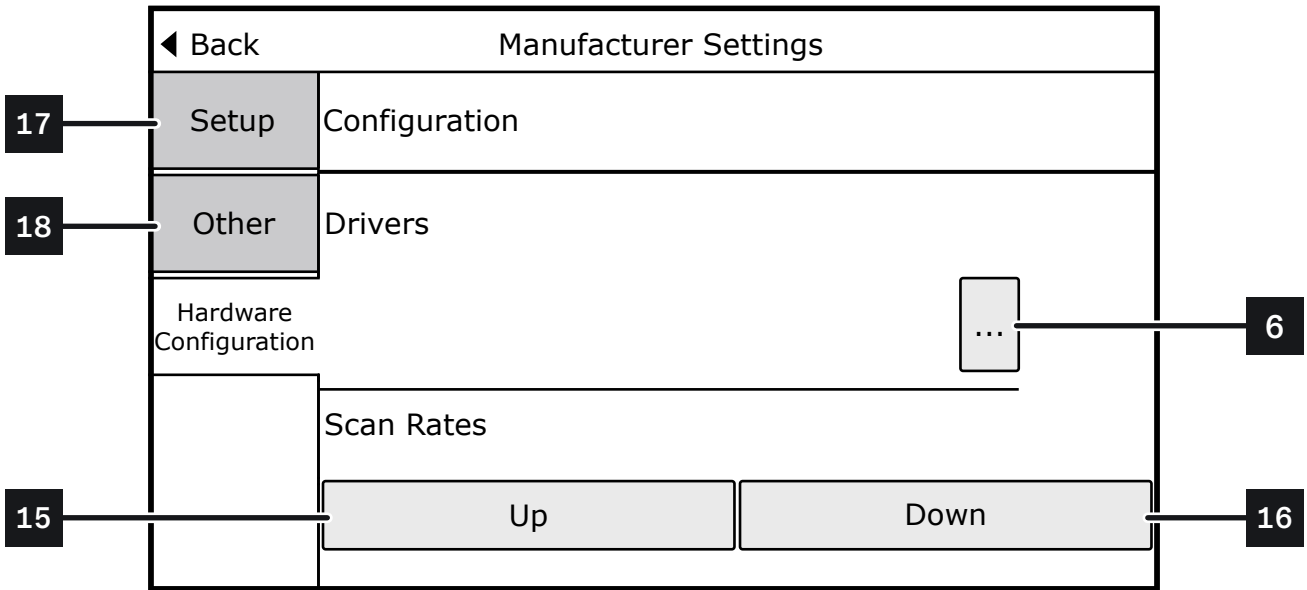
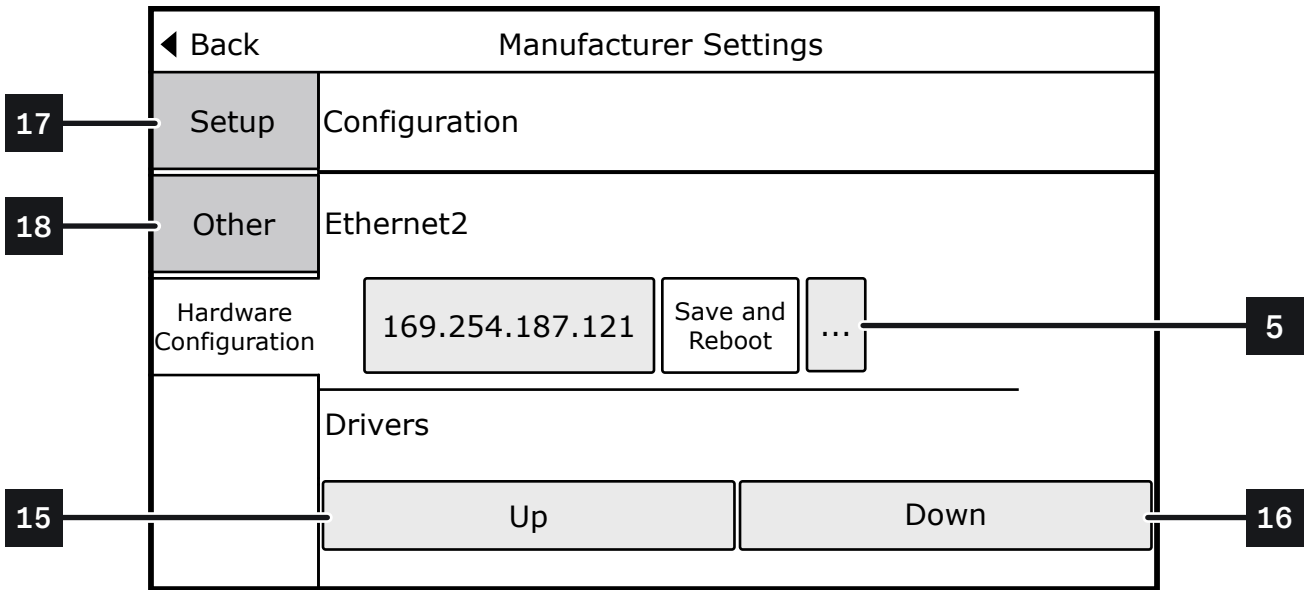

		<u>Options</u>	<u>Description</u>
5	ETHERNET2	###.###.###.###	Configure the IP Address of Ethernet port. This port is currently unused.
6	DRIVERS		Configure the Modbus driver that manages communication between the HMI and PLC. This setting should only be modified under the guidance of Q-PAC Support .
7	SCAN RATES		Configure the scan rate of the HMI. Not pictured.
15	UP		Moves to the previous setting (above).
16	DOWN		Moves to the next setting (below).
17	SETUP		See Page 95 .
18	OTHER		See Page 96 .

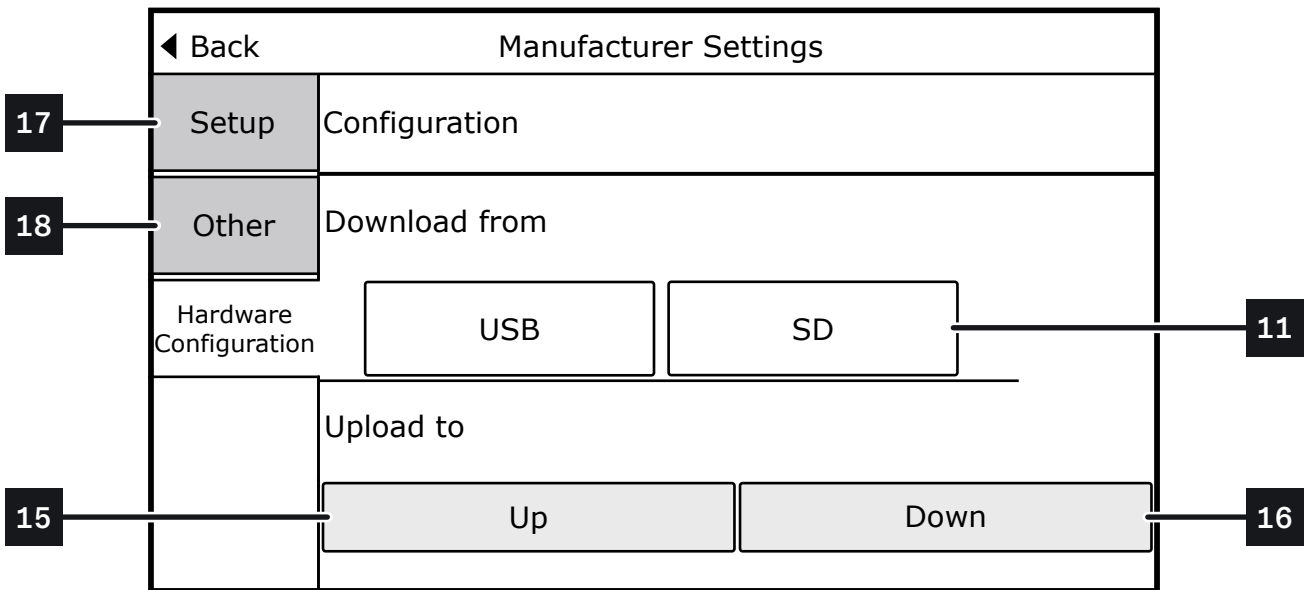
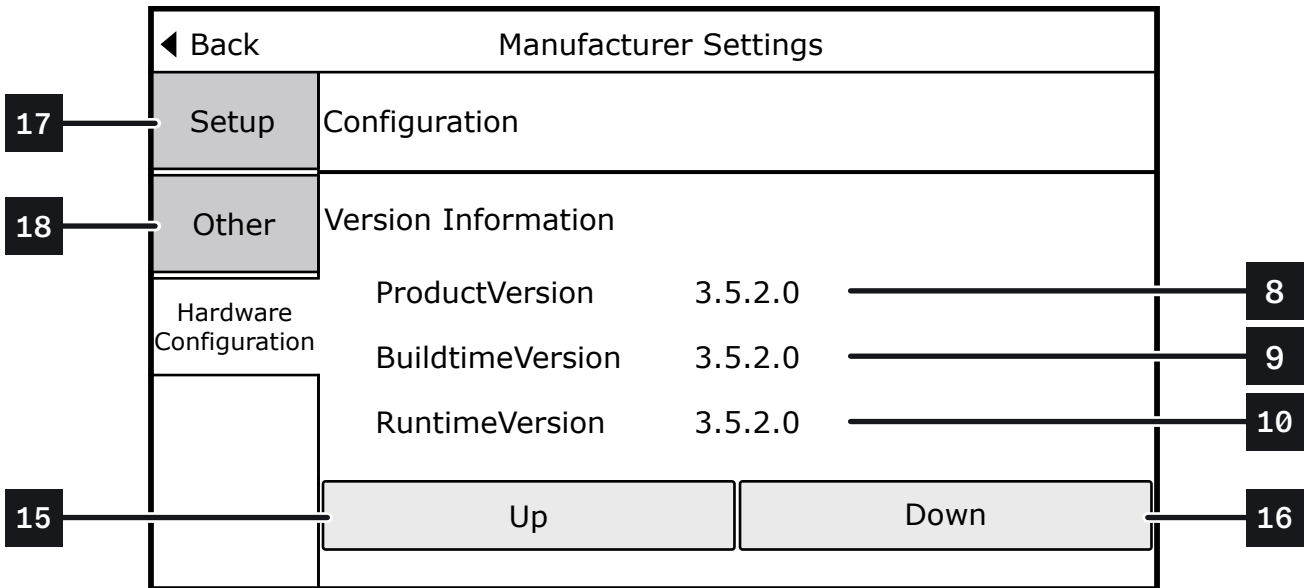

	<u>Options</u>	<u>Description</u>
8	PRODUCT VERSION	HMI operating system version.
9	BUILDTIME VERSION	Version of the firmware used to compile for the HMI.
10	RUNTIME VERSION	Version of the firmware installed on the HMI.
11	DOWNLOAD FROM USB SD	Used by Q-PAC Support to download firmware updates to the HMI.
15	UP	Moves to the previous setting (above).
16	DOWN	Moves to the next setting (below).
17	SETUP	See Page 95.
18	OTHER	See Page 96.

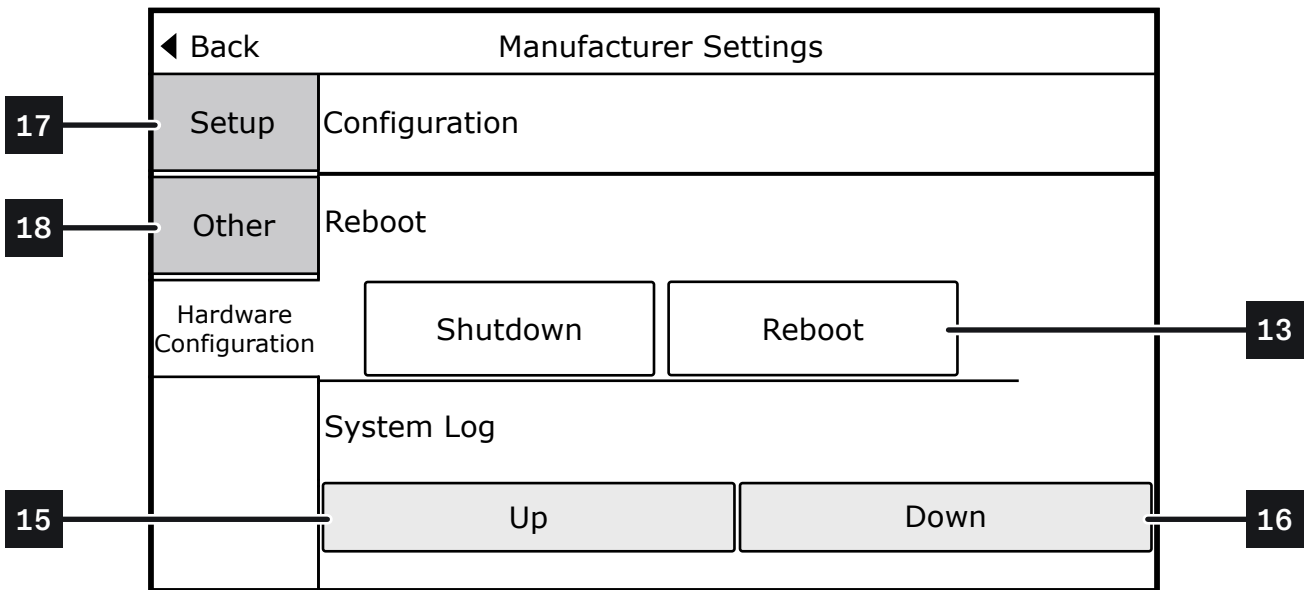
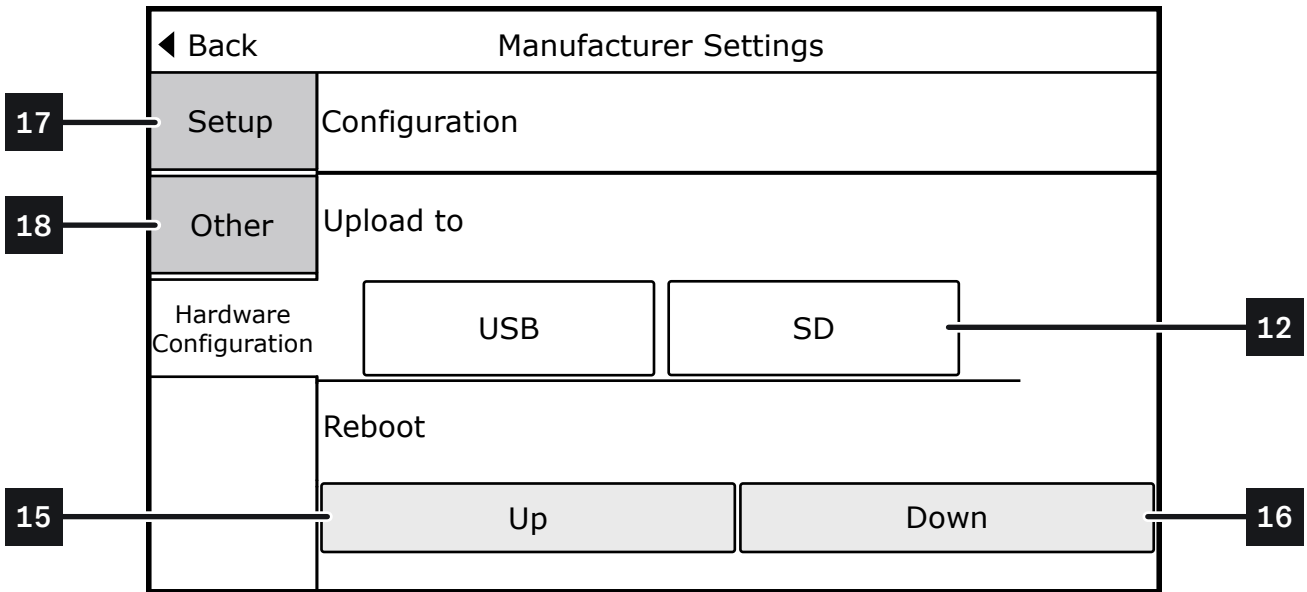

		<u>Options</u>	<u>Description</u>
12	UPLOAD TO	USB SD	Used by Q-PAC Support to download the current firmware to portable media for review.
13	REBOOT	Shutdown Reboot	Shutdown or restart the HMI.
14	SYSTEM LOG		View a log of all actions performed by the user, including page/screen navigation.
15	UP		Moves to the previous setting (above).
16	DOWN		Moves to the next setting (below).
17	SETUP		See Page 95 .
18	OTHER		See Page 96 .

MAINTENANCE

INLET CONE ALIGNMENT

Proper alignment of the inlet cone is important for optimal airflow and efficiency, but also to minimize vibration and noise and ensure motor and bearing life is maximized. Improper alignment may cause uneven air distribution across the plug fan blades. This can cause unbalanced aerodynamic forces which may appear as vibration, rattling, and other noise, but ultimately may result in added stress on the motor bearings. This may result in reduced motor life and premature failure, on top of reduced performance and increased power consumption over time.



Ensure power is disconnected to the fan before attempting inlet cone alignment or any other maintenance or service on the fan or components.

To align the plug fan inlet cone(s):

1. Identify which inlet cones are out of alignment. To identify inlet cones which are out of alignment, check for the following:
 - i. There is noticeable material transfer/residue on the inlet cone or other signs of scraping.
 - ii. When rotating the impeller, there is an audible rubbing or scraping sound.
 - iii. When rotating multiple impellers simultaneously, at even speeds, one impeller stops rotating considerably earlier than the other.
2. On the upstream side of the unit, loosen (but do not remove) the fasteners securing the inlet cone to the fan plate.
3. Adjust the position of the inlet cone and ensure there is no further contact with the impeller. It is recommended that all conditions of Step 1 are rechecked.
4. Tighten the inlet cone fasteners.
5. Repeat **Step 1** for the next plug fan impeller.

INLET CONE
FASTENERS

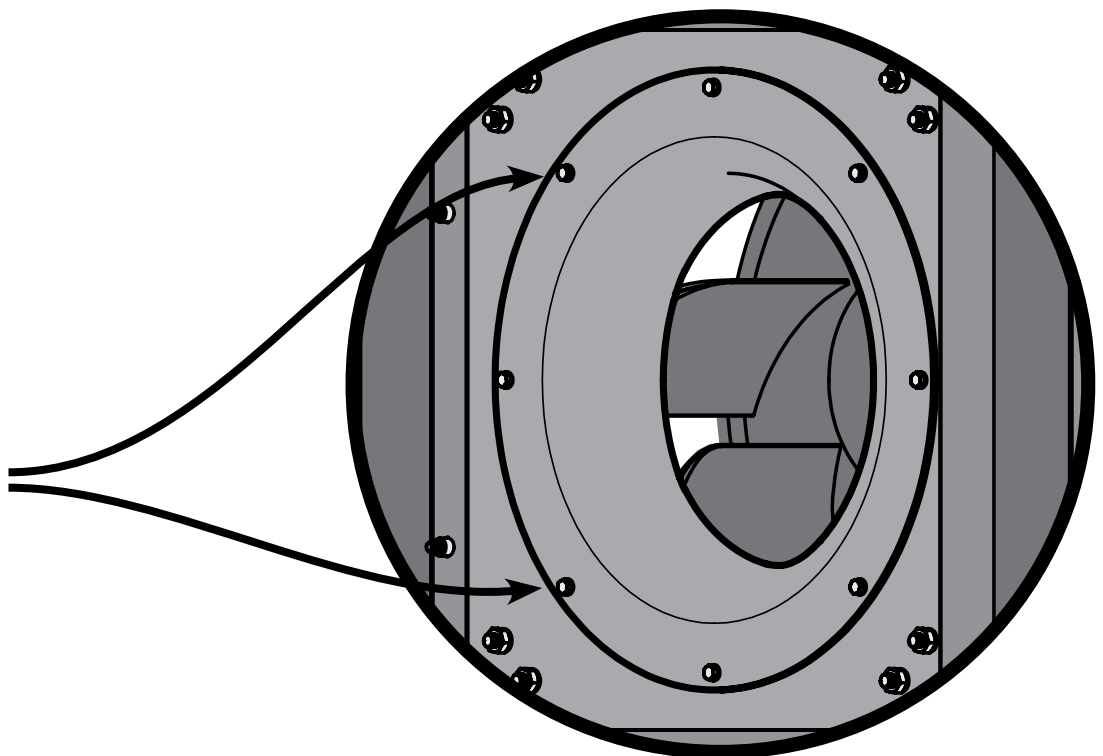

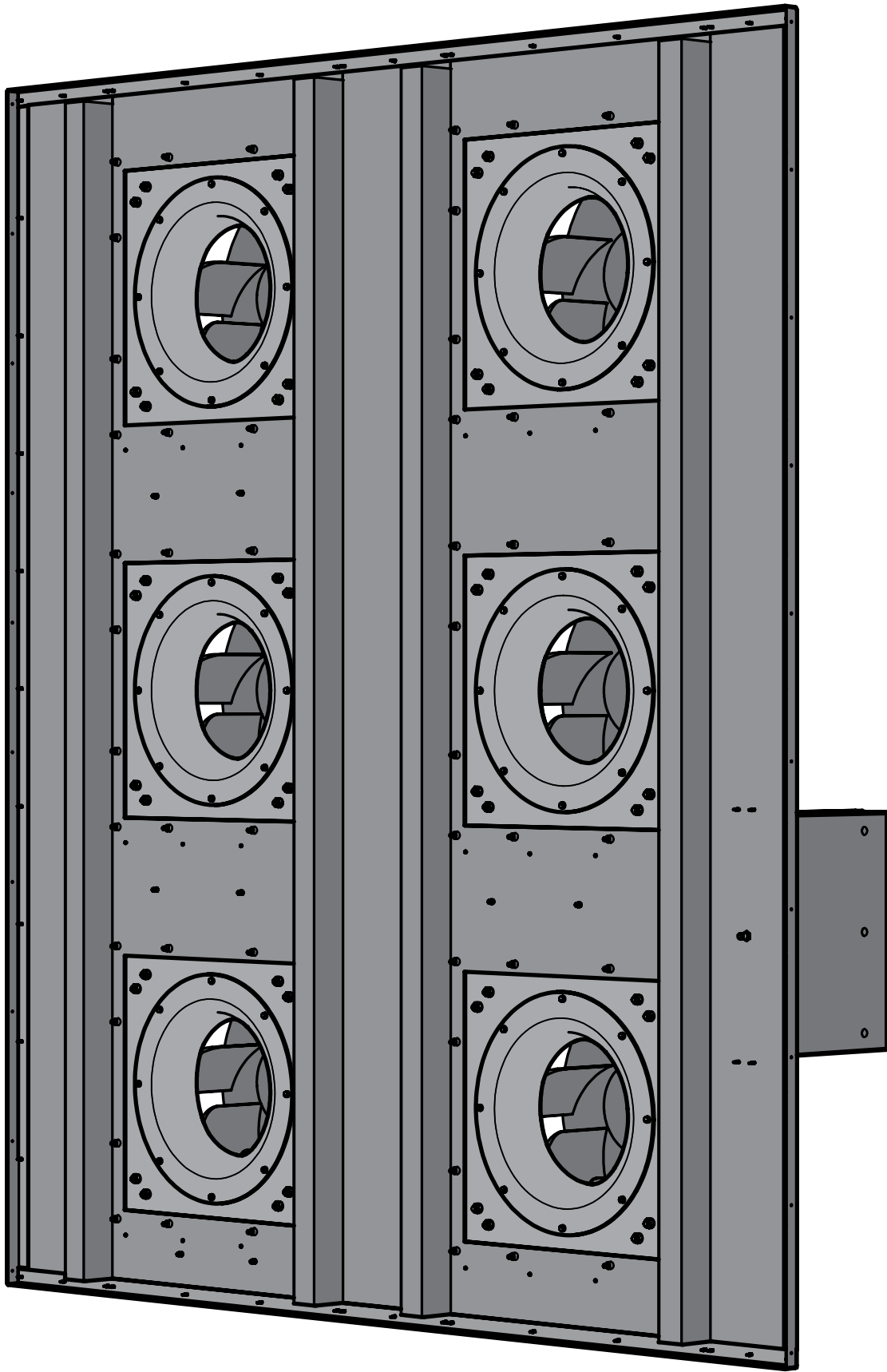

UPSTREAM VIEW

PLUG FAN REMOVAL

Over the operating life of the Q-PAC Fan(s), it may be necessary to replace **Plug Fans** due to damage or malfunction. The Q-PAC Fan is designed for **Plug Fans** to be swapped with the removal of a few bolts.



Ensure the Disconnect is OFF and there is no power to the fan before attempting inlet cone alignment or any other maintenance or service on the fan or components.

1. Disconnect the power and control plugs from the frame ledge by pinching the plug tab(s) and pulling the plug away.
2. Remove the pressure tubing from the nozzle by pressing downward on the plastic ring and pulling the tubing out.
3. Unfasten each bolt along the perimeter of the **Plug Fan** mounting plate. Ensure that the **Plug Fan** is properly braced when removing the final bolt to ensure that it does not fall forward. Save these bolts for installing the new **Plug Fan** or **Blank-Off Plate**.
4. Lift the **Plug Fan** upward, and away from the frame ledge.

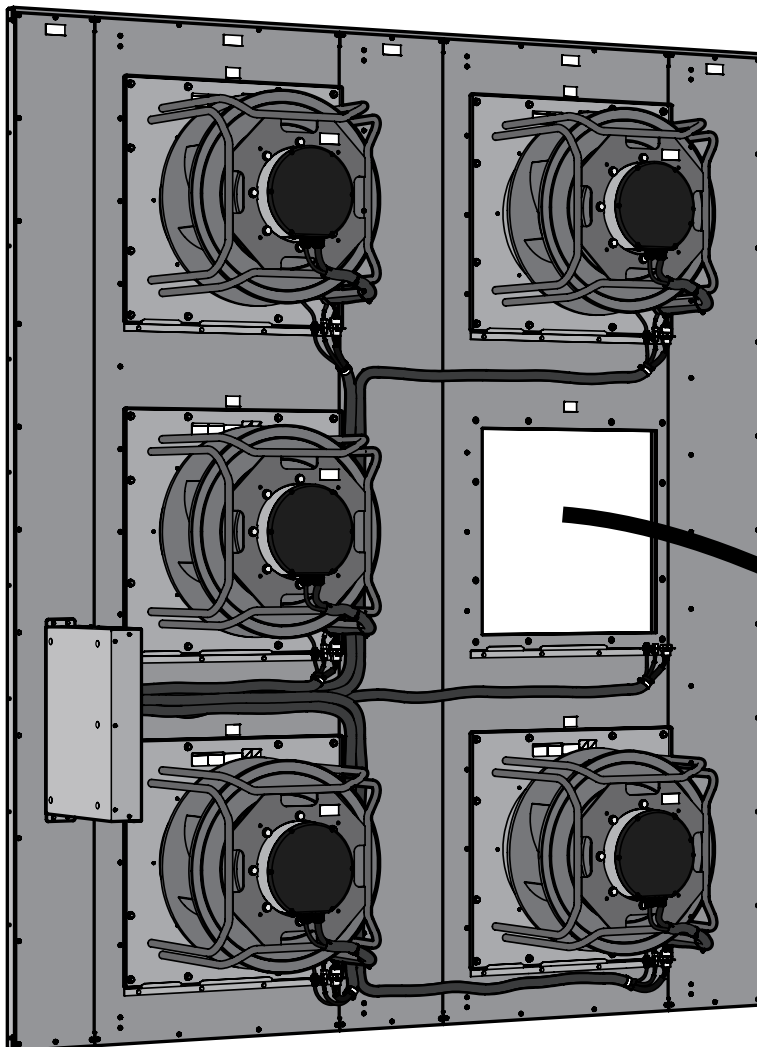
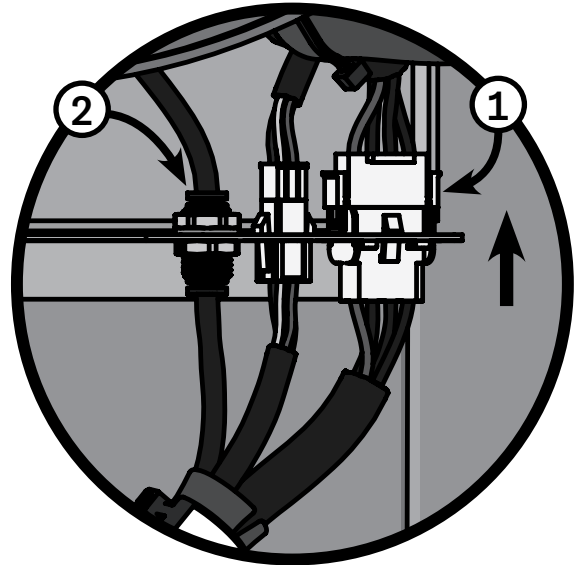

TOOLS & FASTENERS

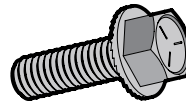

5/16"-18 x 1" or 1/2"-13-1
Hex Serrated Flange Bolt



5/16" or 1/2" Hex Head
Drive



PLUG FAN OR BLANK-OFF PLATE INSTALLATION

If there is spare **Plug Fan (A)** available when removing a one after failure, it is recommended that it is installed in place of the old **Plug Fan**. If not, a **Blank-Off Plate (B)** can be installed instead to prevent backflow when operating until a replacement is available.



Ensure the Disconnect is OFF and there is no power to the fan before attempting inlet cone alignment or any other maintenance or service on the fan or components.

PLUG FAN INSTALLATION (A)

1. Lift the **Plug Fan** up and onto the open ledge. Brace the **Plug Fan** against the frame to ensure it does not fall forward.
2. With the **Plug Fan** braced, fasten the **Plug Fan** to the **Fan Frame**.
3. Reconnect the power and control plugs and insert the pressure tube into the nozzle of the ledge.
4. Check inlet cone alignment (**Page 104**) before returning the fan to service.

BLANK-OFF PLATE INSTALLATION (B)

1. Set the **Blank-Off Plate** onto the open ledge. Brace the **Blank-Off Plate** against the frame to ensure it does not fall forward.
2. With the **Blank-Off Plate** braced, fasten the to the **Fan Frame**. Set unused bolts aside for re-use when a replacement **Plug Fan** is received.

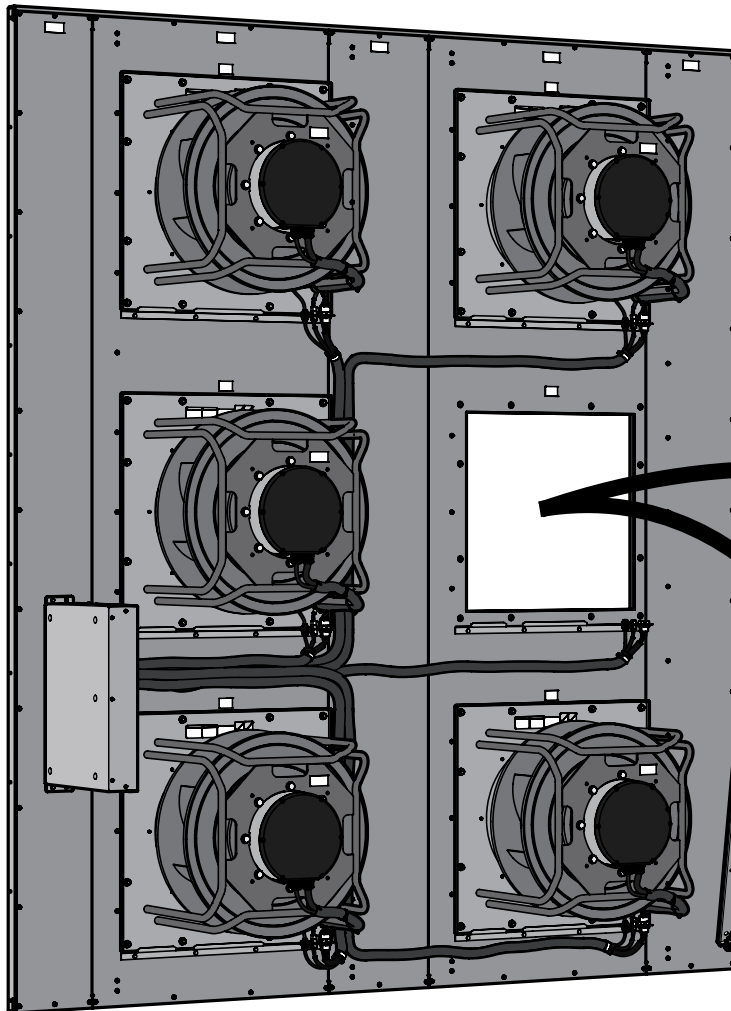

TOOLS & FASTENERS

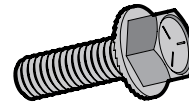

5/16"-18 x 1" or 1/2"-13-1
Hex Serrated Flange Bolt



5/16" or 1/2" Hex Head
Drive

Q-PAC

For assistance, questions, or troubleshooting, contact
Q-PAC Support at 904-863-5300 or support@q-pac.com