

Q-PAC

**BASIC
USER MANUAL
V3.1**

TABLE OF CONTENTS

SYSTEM OVERVIEW

SAFETY INFORMATION.....	6
RECEIVING AND HANDLING.....	7
SHORT TERM STORAGE.....	7
LONG TERM STORAGE.....	7
FAN LAYOUT.....	8
FAN ACCESSORIES	10
NAMEPLATES.....	12
CONTROL PANEL LAYOUT.....	14
FAN CONTROLLER LAYOUT.....	16
POWER HARMONICS.....	20
AIRFLOW MEASUREMENT.....	22

WIRING THE Q-PAC FAN

WIRING PREPARATION.....	26
FAN WIRING.....	28
SINGLE FAN	28
MULTIPLE FANS	30
CONTROL PANEL WIRING.....	32
FAN CONTROLLER BOARD.....	34
ELECTRICAL CHARACTERISTICS.....	36
TORQUE TIGHTENING REQUIREMENTS.....	38
START-UP AND TESTING.....	40

MAINTENANCE

INLET CONE ALIGNMENT.....	44
PLUG FAN REMOVAL.....	46
PLUG FAN OR BLANK-OFF PLATE INSTALLATION.....	47

SYSTEM OVERVIEW

SAFETY INFORMATION

The system design and installation must follow accepted industry practice as described in the ASHRAE Handbook, the National Electric Code, UL 60335-2-40, and other applicable standards. The equipment must be installed in accordance with regulations of authorities having jurisdiction and all applicable codes. Best practices shall be used to determine fan and control panel locations in the air handler. Installation and maintenance must be performed by qualified personnel familiar with the applicable codes and regulations, and experienced with this type of equipment.

Sheet metal parts, screws, mounting frames, clips, and other components may inherently have sharp edges which could cause injury; the installer must exercise caution.

For optimum safety and operation, the Q-PAC Fan must be installed at least one blade diameter away from upstream components or surfaces, and at least three feet (3 ft) from downstream components or surfaces.

For additional information and support, contact **Q-PAC Support** at (904) 863-5300 or support@q-pac.com.



ELECTRICAL HAZARD

Turn off power and lock out all switches and devices before beginning installation or servicing.



QUALIFIED PERSONNEL

Installation and servicing should be performed by qualified personnel only. Appropriate personal protective equipment recommended.



ELECTRICAL CODES

This equipment shall be installed and operated per all applicable local codes.



ENCLOSURE RATING

To maintain the enclosure rating, installation shall utilize only those devices having the same or higher rating when installed to the manufacturer's specifications.



SUPERVISION

This appliance is not intended for use by persons (including children) with reduced physical, sensory or mental capabilities, or lack of experience and knowledge, unless they have been given supervision or instruction concerning use of the appliance by a person responsible for their safety. Children should be supervised to ensure that they do not play with the appliance.



REPLACEMENT PARTS

For proper motor protection and short circuit coordination, parts shall be replaced with identical parts (brand and model) or other factory-authorized parts.

RECEIVING AND HANDLING

The Q-PAC Fan, as referenced in this guide, is shipped knockdown—arriving as a collection of pallets for on-site assembly, or may be received as a singular assembly. Upon receipt, all pallets and/or crates should be carefully inspected for signs of damage and tampering. If any signs are found, ensure that the Bill of Lading (BOL) is annotated with details of the affected items and contact **Q-PAC Support** at **(904) 863-5300** or **support@q-pac.com** to have a claim opened. Q-PAC Support will then begin the process to replace all affected items.

Upon successful receipt of shipment, keep all pallets and/or crates together, unopened, until ready for assembly to ensure that no components are lost or damaged.

SHORT TERM STORAGE

Short term storage requirements shall apply for systems which will be placed in service within one year from the date of shipment. Improper storage may result in impaired functionality and component failure. Components shall be stored indoors, in a temperature-controlled environment, free from moisture, dirt, debris, and excessive vibration. Components shall be stored in their original packaging unless installed in an air handler meeting these storage conditions.

LONG TERM STORAGE

Long term storage requirements shall apply for systems which will be placed in service after one year but not more than two years from the date of shipment. For storage exceeding two years, contact Q-PAC for storage recommendations. Improper storage may result in impaired functionality and component failure. Components shall be stored indoors, in a temperature-controlled environment, free from moisture, dirt, debris, and excessive vibration. Components shall be stored in their original packaging unless installed in a cabinet meeting these storage conditions.

It is recommended that plug fans are not installed when in long term storage unless they can be operated for at least one hour each month. Plug fans should be stored flat, with the motor axis oriented vertically. Prior to start-up, plug fans shall have the yellow jumper connection removed between the 24V and Digital Input terminals of the motor. The motor shall be powered for at least one hour without this jumper. This is recommended to carry out a reformation of the internal capacitors before applying line voltage to the inverter. Refer to the Plug Fan Assembly Guides for more information on motor wiring.

FAN LAYOUT

The Q-PAC Fan system consists of one or more Q-PAC fans - a variable-speed, multimotor plenum fan consisting of one to nine motors, the fan frame, the Fan Controller, and power/control harnesses. These fans can be connected to and controlled by Q-PAC's Control Panel or any external device through an analog or digital interface (Modbus).

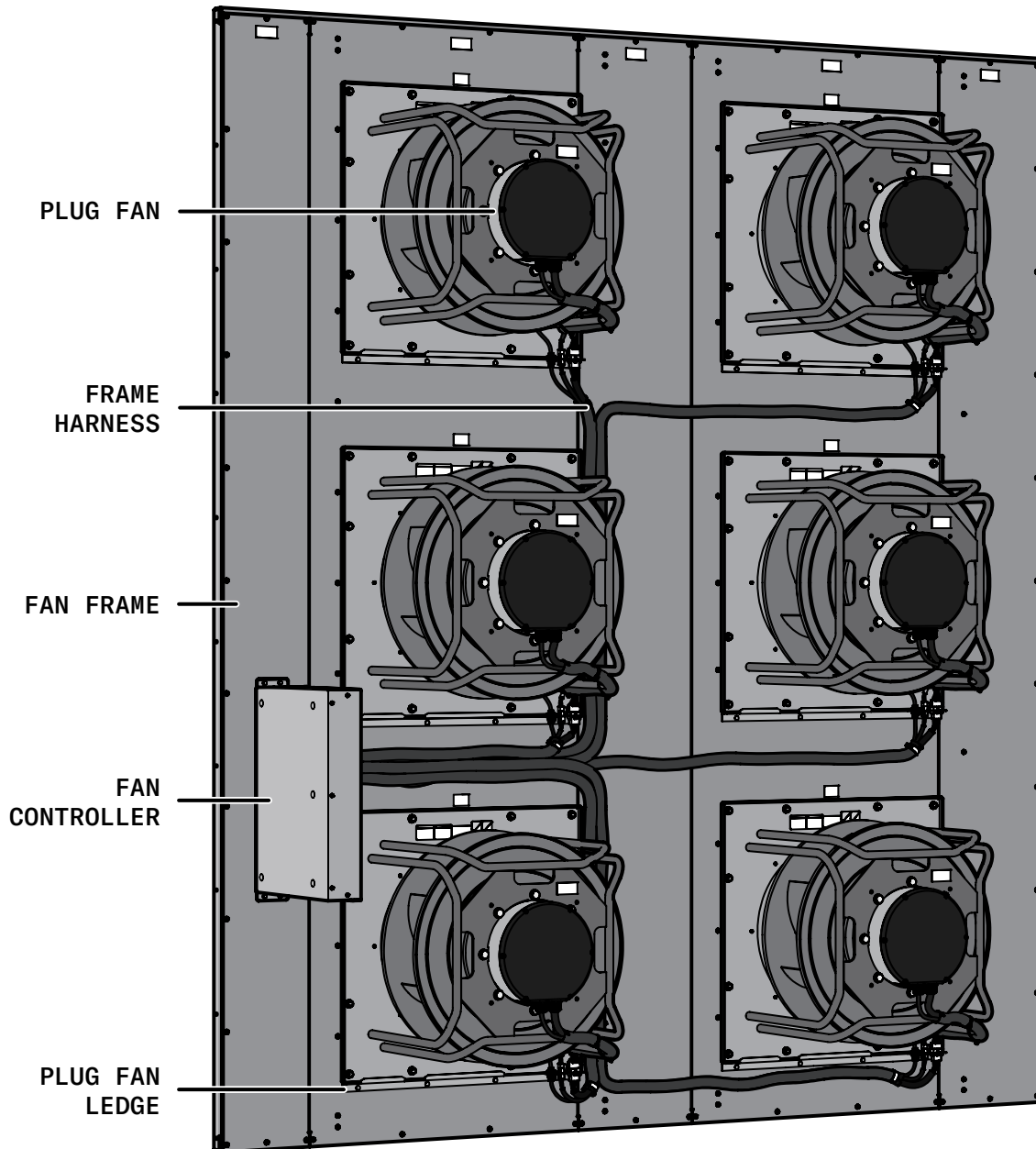

PLUG FAN

The Plug Fan is the interchangeable component consisting of a motorized impeller, inlet cone, motor harness, pressure tube, and supporting frame. The motor harness and pressure tube connect to a dedicated harness secured to the fan frame at the Plug Fan Ledge, which connects to the Fan Controller. The Q-PAC Fan uses plug fans from several manufacturers, given standardized connections by way of the motor harness.

FRAME HARNESS

Each Frame Harness consists of a power cable, control cable, and pressure tube joined within a wire loom. Each harness is manufactured at a specific length, unique to its corresponding route along the Fan Frame, from the Fan Controller to the Plug Fan Ledge. Each harness has a numeric label which corresponds to a set of plugs on the Fan Controller and a labeled route on the Fan Assembly Diagrams.

FAN FRAME

The Q-PAC Fan Frame consists of a set of interlocking galvanized steel panels assembled from left to right to form the pressure wall of the airstream and supporting frame for the Fan Controller, Plug Fans, and Frame Harnesses. Each frame panel consists of a bent structural channel and/or tab for mating with previous panels. The panels include a set of holes along the panel perimeter for securing the frame to the air handler and a set of holes along the channel for fastening successive panels together. Panels may also include a set of holes following the predetermined harness route and a set of a rivet nuts and a Plug Fan Ledge.

FAN CONTROLLER

The Fan Controller serves as the interface point for a Q-PAC fan, distributing power and control signals to each motor. It monitors the status of each motor and enables communication with external devices. The Fan Controller services up to nine motors with plug-and-play connections for power, control, and pressure monitoring, with an additional pressure port to monitor pressure immediately upstream of the Q-PAC fan.

PLUG FAN LEDGE

The Plug Fan Ledge serves as the connection point between each Plug Fan and its corresponding Frame Harness. The ledge secures the Frame Harness plugs to the Fan Frame when replacing a Plug Fan and serve as a support for the weight of the Plug Fan during this process.

FAN ACCESSORIES

CONTROL PANEL - BASIC

The Control Panel is an optional interface for the Q-PAC Fan, installed outside of the airstream to control the Q-PAC Fan(s). Each panel can control up to four Q-PAC Fans (up to nine motors each), though each panel is sized for a set quantity of fans per the order. The Control Panel can control the fans manually, through HAND mode, or automatically, through a 0 - 10 VDC control signal.

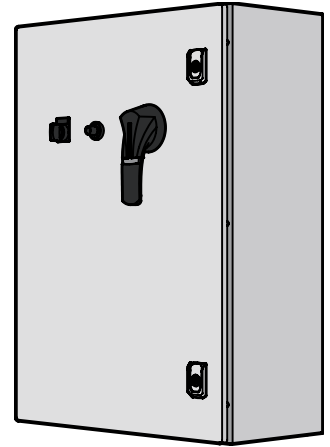

PERIMETER ANGLES

The Perimeter Angle is a set of L-shaped structural galvanized steel components that can be used if the air handler does not include a compatible flange to support the Q-PAC Fan. These angles are secured to flat, sturdy surfaces of the air handler, parallel to the direction of airflow. Perimeter Angles are provided at the system level, supporting one or more Q-PAC Fans as needed. For information on how to install the Perimeter Angles, refer to the Q-PAC Fan Assembly Guide.

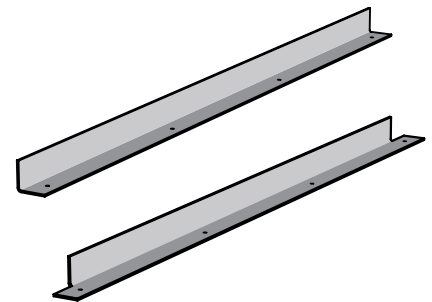

BACKDRAFT DAMPERS

Backdraft Dampers are a type of damper which are spring-loaded or gravity-operated. They automatically open as airflow passes through in one direction, but shut if that airflow stops or reverses. Backdraft Dampers may be used in critical applications to prevent backflow when a motor fails or if the fan is shut off. Q-PAC uses adjustable heavy duty counterweighted dampers.

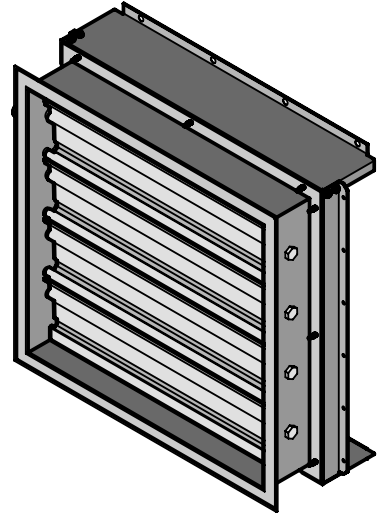

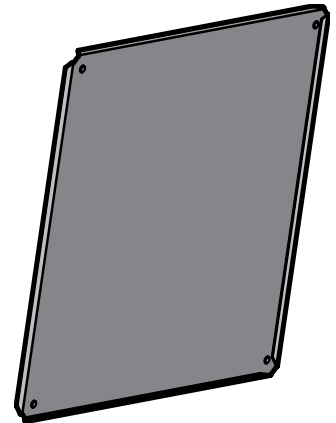

BLANK-OFF PLATE

The Blank-Off Plate provides a manual method of backflow prevention in cases of motor failure. The Blank-Off Plate is installed in place of a Plug Fan to block airflow through that opening in the frame. This is useful when a Plug Fan will not be installed for an extended period of time. Blank-Off Plates may also be utilized in cases in which a fan was designed for a future airflow requirement, but a lower total airflow is required until that time.



NAMEPLATES



CONTROL PANEL

 <p>(904) 863-5300 SUPPORT@Q-PAC.COM 4010 DEERPARK BLVD ELKTON, FL 32033</p>			
SO#:		9230	
TAG:		AHU-1	
MODEL:		1700224	
SERIAL#:		23H9999	
DATE OF MFG:		MM/DD/YYYY	
CONTROL PACKAGE:		BASIC	
POWER:		480V 3~ 60Hz	
SCCR:	100kA RMS SYM AT 460 V		
FLC:		55.70 A	
ENCLOSURE TYPE:		1	
ELECTRICAL DRAWING:		1234	

The Q-PAC Control Panel is UL Listed per **UL 508A**, signifying compliance with North American safety standards. This listing information is displayed on the front of the Control Panel. It is important that the Q-PAC Fan is operated in accordance with the given power ratings, plug fan selection, and other elements to maintain listing compliance.

For further information, contact **Q-PAC Support** at (904) **863-5300** or **support@q-pac.com**.

FAN CONTROLLER

 <p>(904) 863-5300 SUPPORT@Q-PAC.COM 4010 DEERPARK BLVD ELKTON, FL 32033</p>		<p>RECOGNIZED COMPONENT</p>  <p>Intertek 4010006</p>		<p>Q-PAC Fan Conforms to UL 60335-2-40:2022 Ed.4</p> <p>Fan Controller Certified to UL 60730-2-15:2019 Ed.3</p> <p>US Pat. Nos. 11.852.151 11.375.085</p>	
SO#:		9230			
TAG:	7999 (K752)	AHU-99-2 SF			
MODEL:		1-9-1-2-1-1700076			
SERIAL#:		23H9999			
MFG:		MM/DD/YYYY			
MODBUS ADDR:		017			
POWER:		480V 3~ 60Hz			
SCCR:	10kA RMS SYM AT 600 V MAX				
MTR FLA:		7.86 A			
MCA:		72.70 A			
MOCP:		80.00 A			
<p>USE 15 AMP CLASS CC 600V FUSES</p>					

The Q-PAC Fan is an ETL Recognized Component per UL 60335-2-40, CSA C22.2 and UL 60730-2-15. This listing information is displayed on the cover plate of the Fan Controller. It is important that Q-PAC Fan is operated in accordance with the given power ratings, plug fan selection, and other elements to maintain compliance.

For further information, contact **Q-PAC Support** at (904) **863-5300** or **support@q-pac.com**.

Q-PAC FAN MODEL NUMBER

EXAMPLE MODEL NUMBER:

1	-	9	-	1	-	2	-	1	-	1700076
A		B		C		D		E		F

BREAKDOWN:

A PRODUCT CLASS

Internal tracking of product segmentation.

B MOTOR QTY

Number of motors used in the fan. 1 - 9

C MOTOR LAYOUT

Arrangement of motors within the fan, based on motor quantity and aspect ratio. 1 - 22

D INPUT VOLTAGE

Nominal voltage rating of the fan. 1 = 208V 3~ 60Hz
2 = 480V 3~ 60Hz

E BACKFLOW DEVICE

Method of backflow prevention in case of motor failure. 1 = Blank-off Plate
2 = Backdraft Dampers

F PLUG FAN MODEL

Q-PAC model number for the motor and impeller assembly used in the fan. See Page 21 for full list of model numbers.

CONTROL PANEL LAYOUT

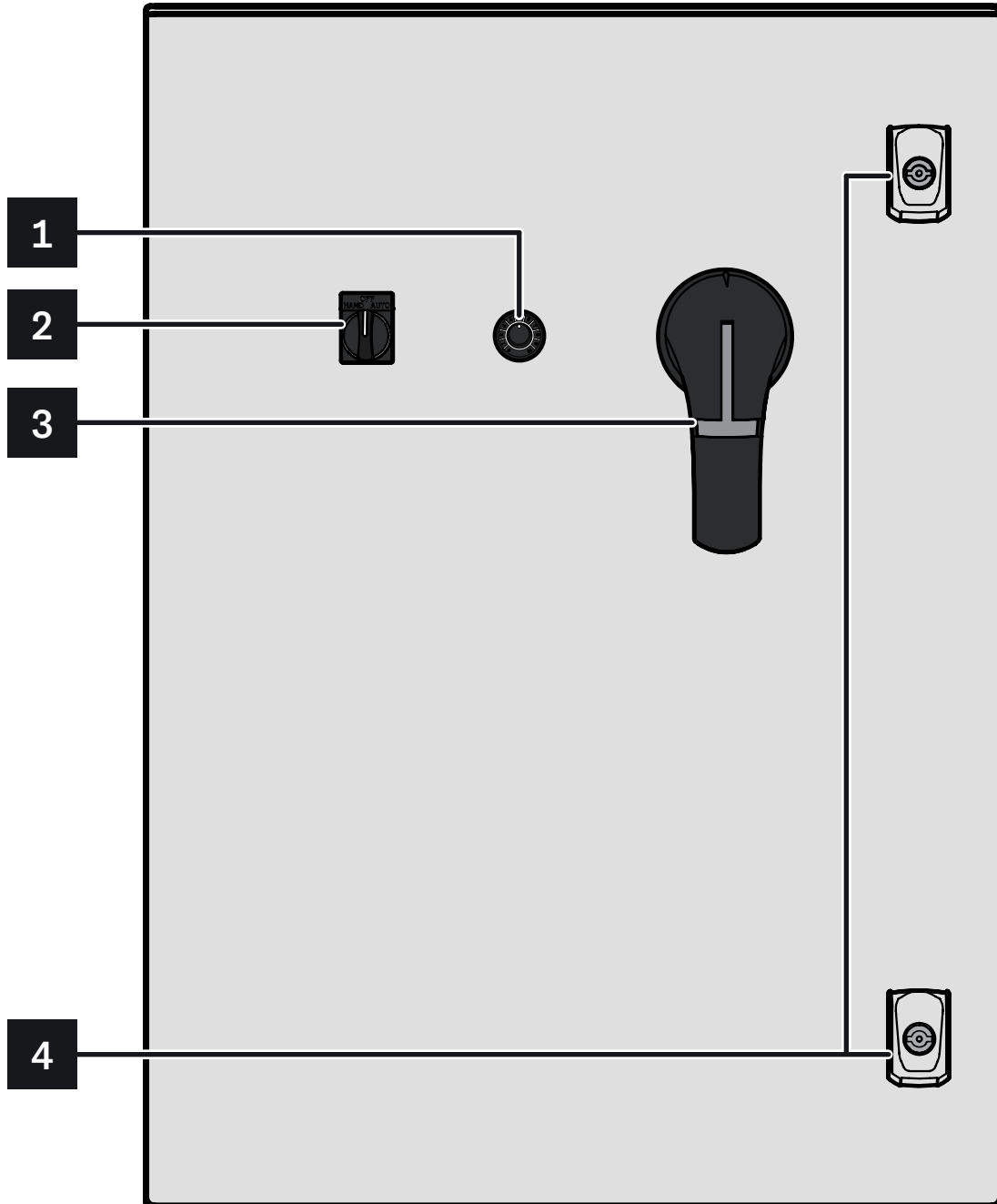

1

POTENTIOMETER

Variable resistor with a rotating dial to manually adjust speed when in HAND MODE.



Use caution when operating the system in HAND MODE. Improper use may result in damage to the upstream or downstream components or ductwork.

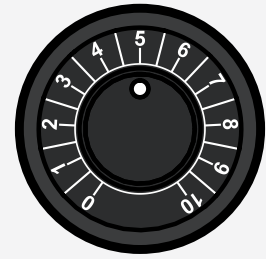

2

HAND / OFF / AUTO (HOA) SWITCH

HAND Bypass the controller and use the potentiometer to control motor speed linearly. Overrides Interlock, Delay on Start Timer, Relay 1 delays, and Fireman Override. Will not override the Safety Circuit.

OFF System is turned off. Motors will not operate.

AUTO System speed is determined by the controller.



3

DISCONNECT HANDLE

Main electrical shutoff of the fan system for service or maintenance.

4

LOCKS

Control Panel door locks, accessible via flathead tool.

FAN CONTROLLER LAYOUT

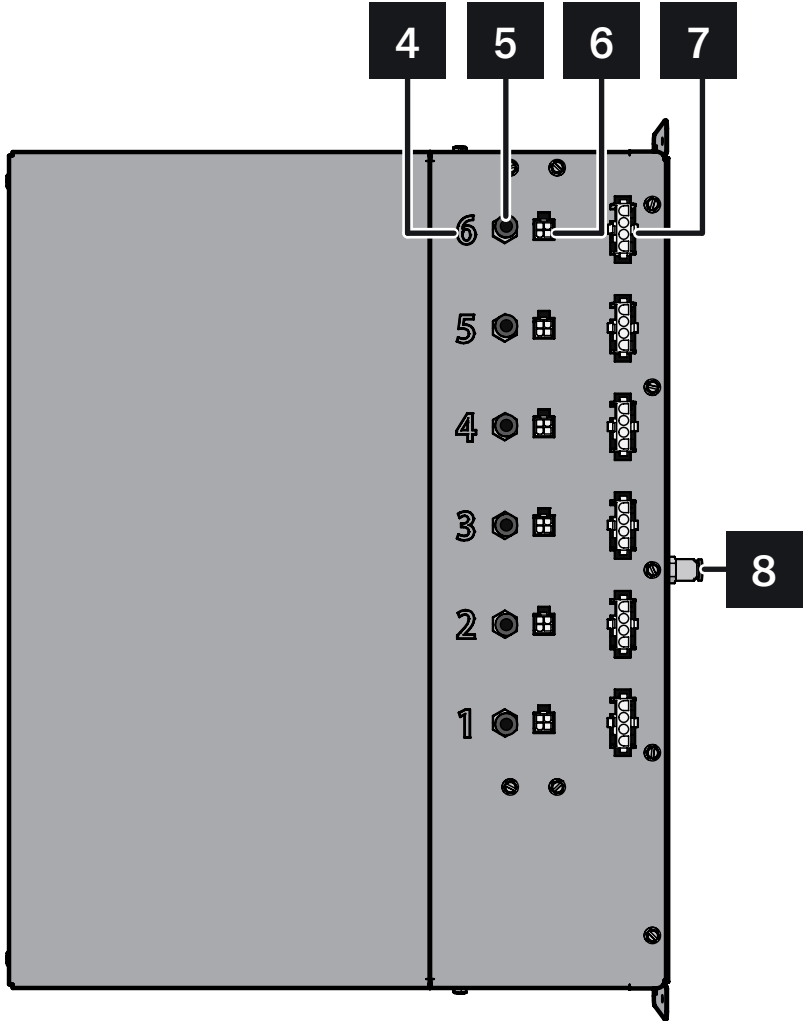
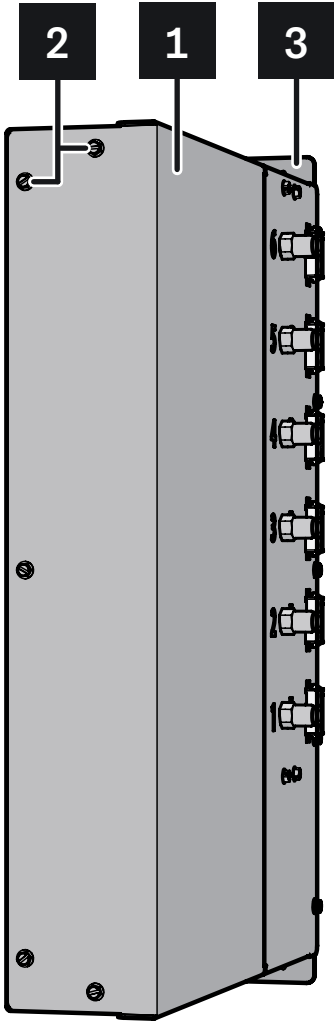

1

FRONT COVER

Removable panel permitting access to the **Q-PAC Fan Controller Board** for field wiring.

2

FRONT COVER SCREWS

Five (5) #8-32 hex head screws with a slotted drive. These screws must be unfastened to remove the **Front Cover**.

3

MOUNTING BRACKETS

Two flanged mounts to secure the Fan Controller to the frame of the Q-PAC Fan. See the **Q-PAC Fan Assembly Guide** for more information.

4

HARNESS INDICATOR

Etched labels on the **Fan Controller** side panel serving as a guide when connecting the harnesses between the Fan Controller and each motor.

5

LOW PRESSURE NOZZLE

Push fitting for the pressure tubing of each harness, corresponding with the etched **Harness Indicator**.

6

CONTROL CONNECTION

Female control receptacle of each harness, corresponding with the etched **Harness Indicator**.

7

POWER CONNECTION

Female power receptacle of each harness, corresponding with the etched **Harness Indicator**.

8

HIGH PRESSURE NOZZLE

Nozzle designed to pass through a cutout in the fan frame to measure pressure immediately upstream of the Q-PAC Fan.

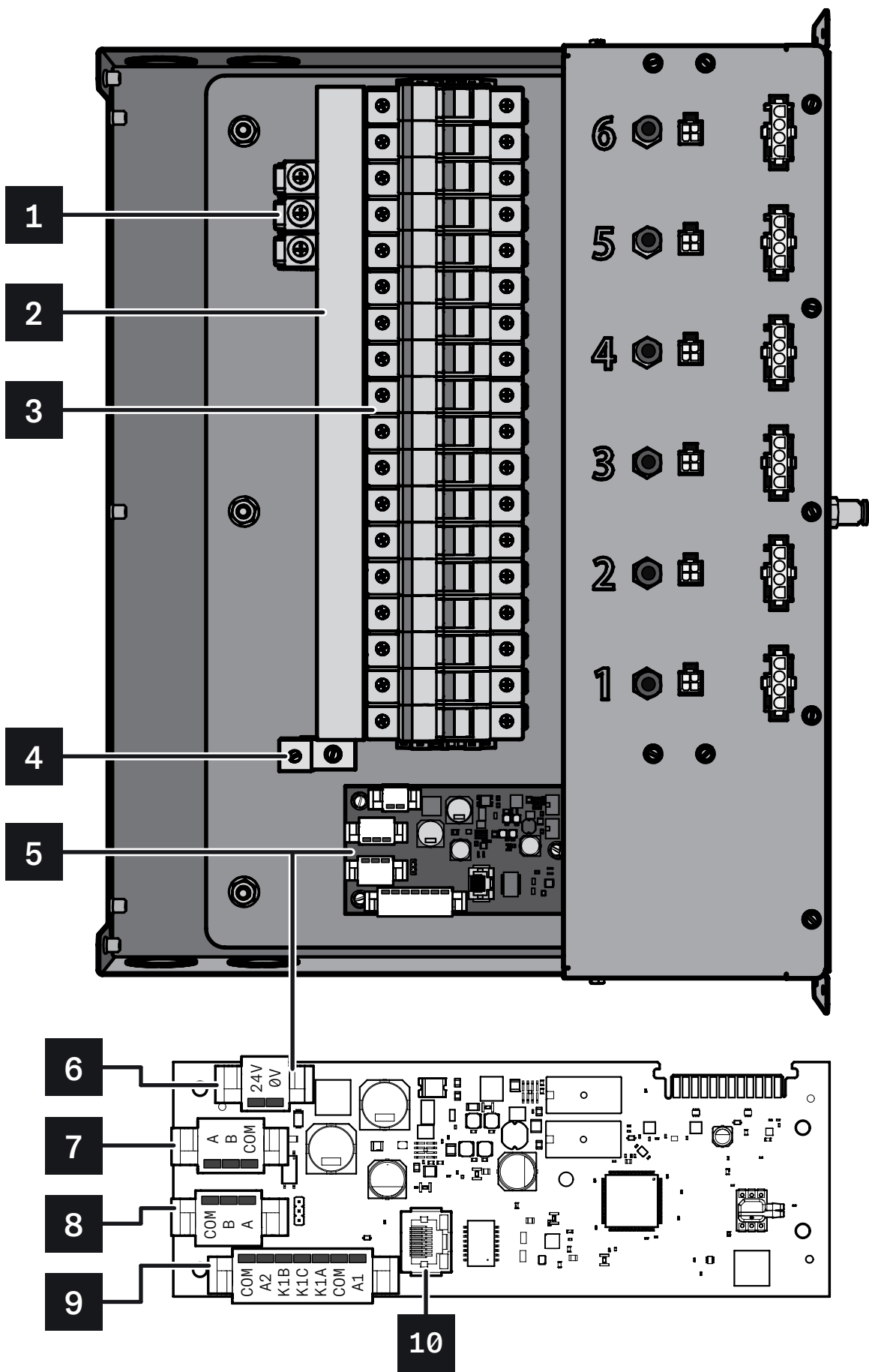

1**INPUT POWER CONNECTOR (PI)**

Input for power to be distributed to the motors of the Q-PAC Fan. Voltage either 208VAC or 480VAC and current up to 96A. See Nameplate for actual values.

2**POWER BUS BAR**

Distributes input power to the fuses.

3**FUSE HOLDERS**

Holds class CC fuses to protect each phase of the power lines to each motor.

4**GROUND CONNECTOR (GND)**

Earth ground connection.

5**FAN CONTROLLER BOARD**

Q-PAC Fan proprietary PCB containing the Control Panel Connector (CN1), Low Voltage Power Supply Input (CN3), Modbus Communication Ports (CN5 and CN6), and Ethernet Port (RJ-45).

6**LOW VOLTAGE INPUT POWER (CN3)**

Provide 24V AC/DC 500mA with a Class 2 supply.

7**COMMUNICATIONS PORT (CN6)**

RS-485 serial data connection.

8**COMMUNICATIONS PORT (CN5)**

RS-485 serial data connection.

9**CONNECTOR TO CONTROL PANEL (CN1)**

Fan Controller input/output connector. See **Page 34** for signal descriptions.

10**ETHERNET PORT (RJ-45)**

Reserved for future usage.

POWER HARMONICS

The term “harmonics” refers to electrical noise. Harmonics result from nonlinear loads converting AC line voltage to DC because of switching devices like variable frequency drives (VFDs), computer power supplies and energy-efficient lighting, which introduce noise at different frequencies.

Harmonics becomes a problem when the noise is strong, or when noise from multiple devices superimposes on a shared transmission line.

Harmonics are often attributed to cumulative noise from several separate devices. Therefore managing harmonics is a joint responsibility involving end-users, system owners or operators, and OEMs. End-users limit what equipment is on which circuit, or change operating set points. System owners and operators modify system characteristics so that voltage distortion levels are acceptable if needed. OEMs, like Q-PAC, ensure their equipment is compliant with applicable conducted emission regulations within the jurisdiction.

For proper operation of an electrical system, harmonic resonance and harmonic distortion should be minimized. Building electrical distribution systems with a large number of nonlinear loads may experience harmonic resonance - the superimposing of noise from multiple devices. This causes harmonic distortion current which can accumulate at a major supply transformer causing harmonic voltage distortion. Common symptoms of issues experiencing harmonics issues include:

- Nuisance tripping of circuit breaker and fuses
- Overheating of motors, cables, or electrical components
- Electromagnetic Interference (EMI) on control and data signals
- Increased installation and utility cost
- Reduced power output from supply transformers

IEEE-519 recommends harmonic measurements and limits. For Q-PAC installations ($V < 1$ kV), the recommendation is to stay below 7.5% individual and 12% total harmonic distortion. This is for the 99th percentile weekly short time, measured at the point of common connection (PCC).

Q-PAC Fans include different motors, with different options for harmonics depending on the original motor manufacturer. Support information for specific models can be found on **Page 21**.

For further information or questions about potential harmonics issues with your system, contact **Q-PAC Support** at **(904) 863-5300** or **support@q-pac.com**.

ZIEHL - ABEGG MOTORS

ZIEHL-ABEGG recommends the following motors receive adjusted programming when used with a passive filter for harmonics. ZIEHL-ABEGG's active harmonic filter may be used without reprogramming the motors. The table below lists the reference model numbers for Q-PAC and ZIEHL-ABEGG.

Contact **Q-PAC Support** at (904) 863-5300 or support@q-pac.com for assistance reprogramming these motors for use with harmonic filters.

Q-PAC	ZIEHL - ABEGG	Q-PAC	ZIEHL - ABEGG	Q-PAC	ZIEHL - ABEGG
1700069	116169	1700074	116167	1700079	116178
1700070	116552	1700075	116174	1700080	116182
1700071	116553	1700076	116175	1700081	116181
1700072	117050	1700077	116176	1700082	116165
1700073	116617	1700078	116177	1700083	117885

ROSENBERG MOTORS

Rosenberg motors do not require reprogramming, but are recommended for use with an active filter, if necessary for the application.

Q-PAC	ROSENBERG
1700090	N88-40327
1700091	N88-45316
1700519	N88-40303
1700523	N88-50322
1700526	N88-35831

EBM - PAPST MOTORS

EBM's RadiPac and RadiCal series of EC centrifugal fans have an integrated 3-phase active PFC solution that enables their motors to achieve a power factor of 0.99 and a THDI value of less than 5 percent. This applies to model 1700143.

Q-PAC	EBM - PAPST
1700141	EG1R240-450-282
1700143	EG1R480-450-282

AIRFLOW MEASUREMENT

Q-PAC Fans calculate airflow based upon the pressure differential across each motorized impeller - the static pressure immediately in front of the inlet cone and the pressure at the narrowest point of the inlet cone. This technique is based on the Bernoulli and Continuity equations, which provide for the calculation of airflow through a converging nozzle based upon measurement of the static pressure across the nozzle.

Q-PAC Fans measure this differential pressure with a dedicated pressure transducer for each motorized impeller, reporting the measured value back to the controller to calculate airflow through that impeller. This value can be accessed via AO1 on the Fan Controller Board (Page 34); this connection is not included in the Q-PAC Basic Control Panel. This 0 - 10V output is linearly scaled between 0 and the maximum airflow of the motorized impeller of the Q-PAC Fan. For example, a 5V signal translates to 50% of the maximum airflow of the fan. The equation for this model is given as:

$$\text{Airflow} = \frac{V}{10} \times N \times q_{\max}$$

Where,

V	=	0 - 10V signal
N	=	Number of motors
q_{max}	=	Maximum airflow of an individual plug fan

For further information, contact **Q-PAC Support** at (904) 863-5300 or support@q-pac.com.

AIRFLOW REFERENCE VALUES

The following tables give the maximum airflow, in CFM, for each plug fan model. These values are multiplied by the measured voltage across AO1+ (Page 34) and the number of motors in the fan to calculate the fan's total airflow.

MODEL	MAX AIRFLOW	MODEL	MAX AIRFLOW	MODEL	MAX AIRFLOW
1700032	3950	1700042	3400	1700051	7500
1700033	9400	1700043	2900	1700052	7800
1700034	3900	1700044	4400	1700053	8900
1700036	6800	1700045	4800	1700054	9200
1700037	7900	1700046	3600	1700055	10400
1700038	4200	1700047	5000	1700056	5400
1700039	4700	1700048	5600	1700057	4200
1700040	3400	1700049	6250	1700058	4200
1700041	5300	1700050	6600	1700059	9800

MODEL	MAX AIRFLOW	MODEL	MAX AIRFLOW	MODEL	MAX AIRFLOW
1700060	4300	1700072	6800	1700082	4200
1700061	10200	1700073	4200	1700083	5500
1700062	9700	1700074	3600	1700100	7000
1700064	9200	1700075	5000	1700101	8900
1700066	5500	1700076	6250	1700140	9190
1700067	13400	1700077	6600	1700141	9100
1700068	18900	1700078	7500	1700143	9710
1700069	4800	1700079	9000	1700515	3300
1700070	3400	1700080	9200	1700519	5300
1700071	3950	1700081	10400		

The following models support multiple voltages, though maximum airflow varies with the input voltage.



The Q-PAC Fan should only be operated within its rated voltage range. Please contact **Q-PAC Support** at (904) 863-5300 or support@q-pac.com if the fan must operate at a different voltage.

MODEL	INPUT POWER	MAX AIRFLOW	INPUT POWER	MAX AIRFLOW
1700090	200-240V 3~ 60Hz	5400	440-480V 3~ 60Hz	5900
1700091	200-240V 3~ 60Hz	6750	440-480V 3~ 60Hz	7100
1700523	200-240V 3~ 60Hz	8400	440-480V 3~ 60Hz	9800
1700526	200-240V 3~ 60Hz	4300	440-480V 3~ 60Hz	4900

**WIRING THE
Q - PAC FAN**

WIRING PREPARATION



Wiring the Q-PAC Fan should be completed only after the fan has been fully assembled and installed in the air handler. Refer to the **Q-PAC Fan Assembly Guide**.

Wiring the fan consists of three main steps:

1. Removing the Q-PAC Fan Controller Cover Plate
2. Removing the knock-out port(s) for conduit installation
3. Wiring the Fan Controller Board terminals

REMOVING THE FAN CONTROLLER COVER

To remove the Fan Controller Cover Plate,

1. Remove the five (5) #8-32 hex head screws using either a 1/4" hex head drive or a standard or slotted (flathead) screwdriver.
2. Slide the Cover Plate forward, away from the Fan Frame, and out, away from the Fan Controller to access the internal fuses and terminals.

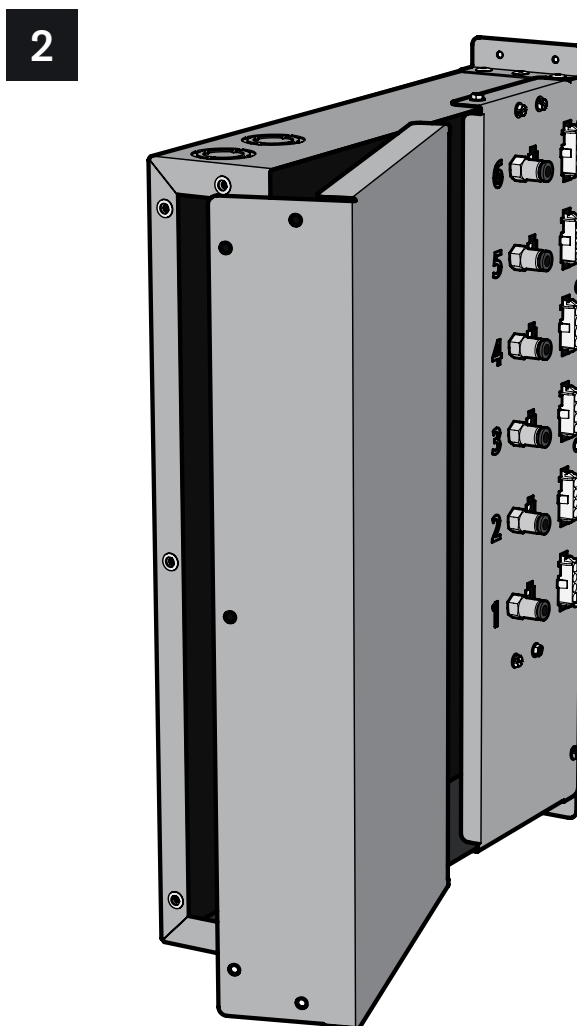
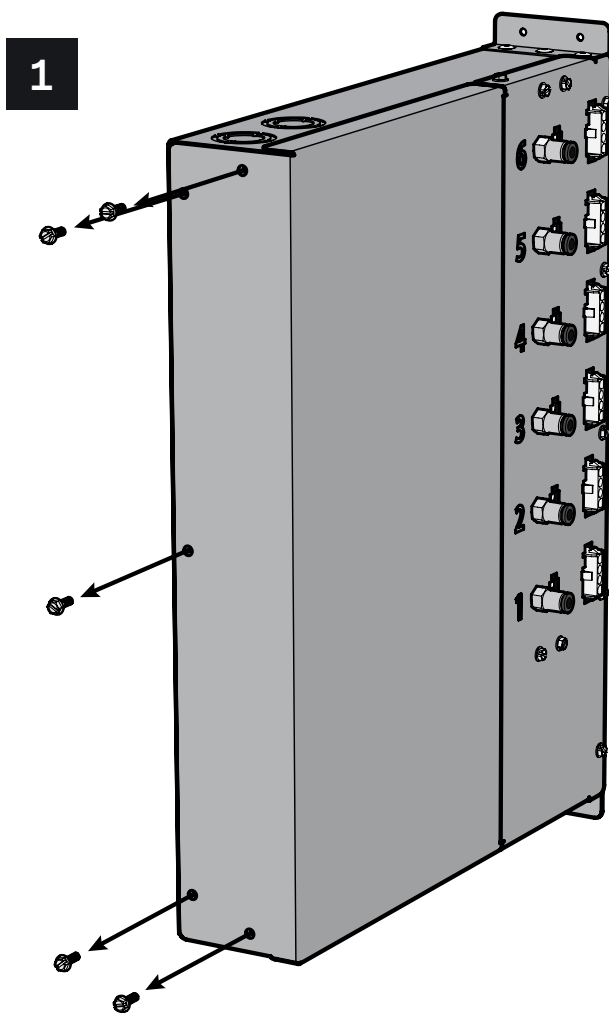

REMOVING THE FAN CONTROLLER KNOCKOUT PORTS

The Fan Controller includes four knockout ports, two each at the top and bottom of the unit. Each port features three (3) size options to suit standard trade sizes of 1/2 in, 3/4 in, and 1 in.

1/2 in AND 1 in KNOCKOUTS

1. Using a standard or slotted (flathead) screwdriver and mallet (or similar tools), position the tip of the screwdriver just inside the edge of the knockout, near one of the tabs.
2. Tap the screwdriver with the mallet to push the knockout away from the shell of the Fan Controller.
3. Repeat until the knockout is free, using a set of pliers or similar tools as necessary to fully remove the knockout.

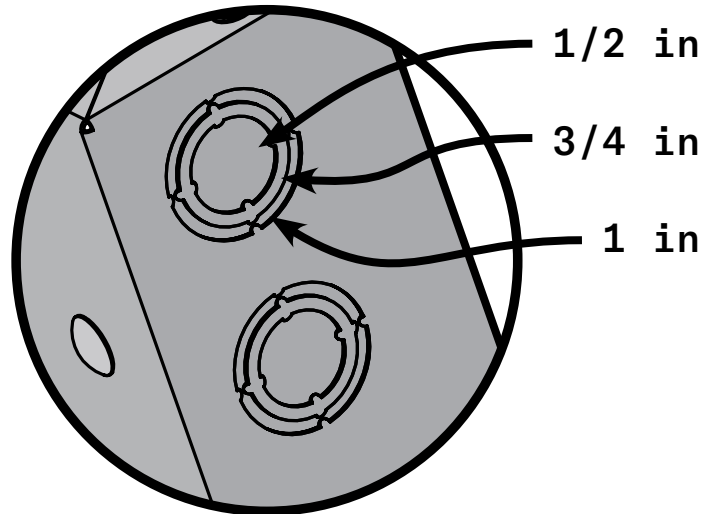

3/4 in KNOCKOUTS

1. Using a standard or slotted (flathead) screwdriver, pry the center ring of the knockout forward, away from the shell, at opposing sides.
2. Using a set of pliers or similar tools, bent these tabs back and forth until the connection breaks free.

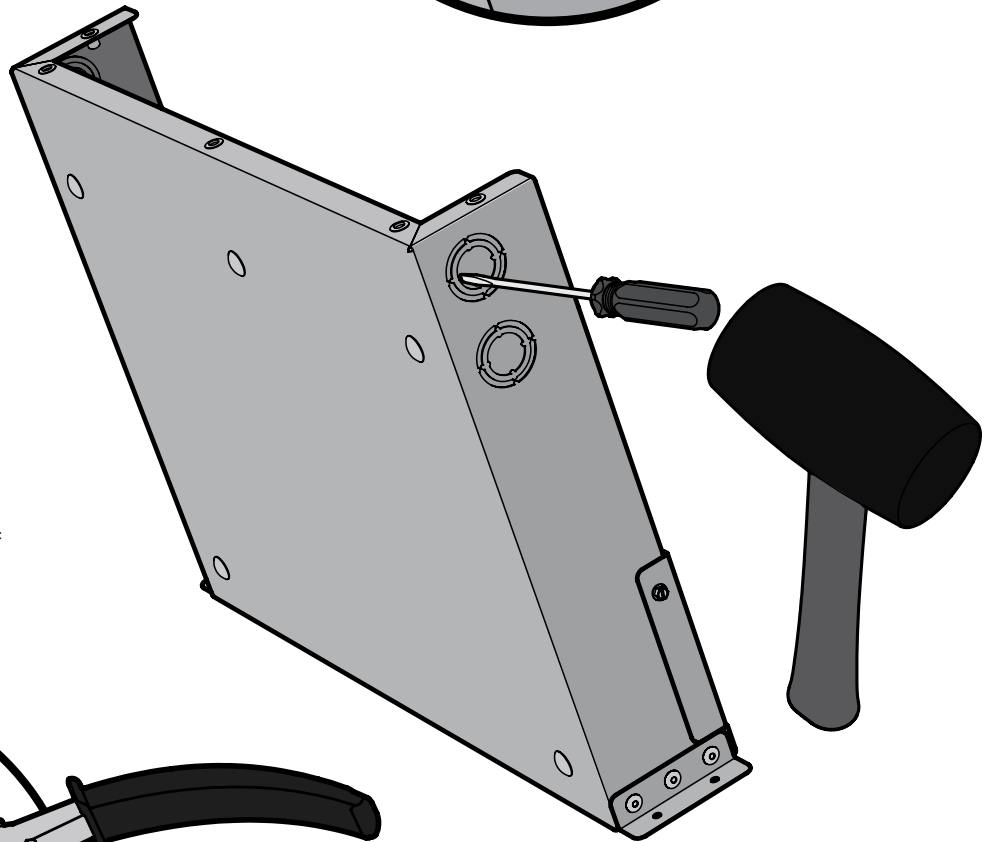

Use caution when removing the knock-outs to ensure that internal components of the **Fan Controller** are free from damage.

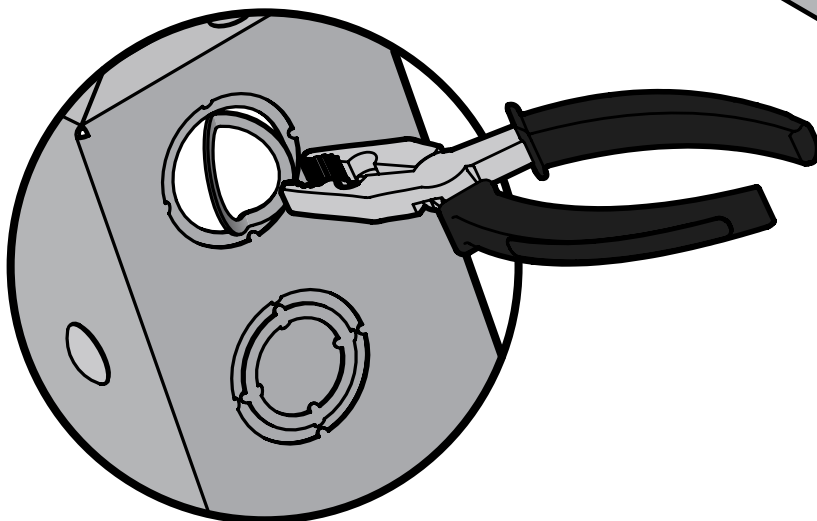

FAN WIRING

The Control Panel has a dedicated set of terminals for power and controls for each Q-PAC Fan. This means that, for multiple fans, there is no need to daisy chain controls between fans. For systems of only one fan, there will be no connection present for the CN5 or CN6 terminals. The wiring of the single and multiple-fan conditions are given below and in the reference Wiring Guides provided with the order.

SINGLE FAN

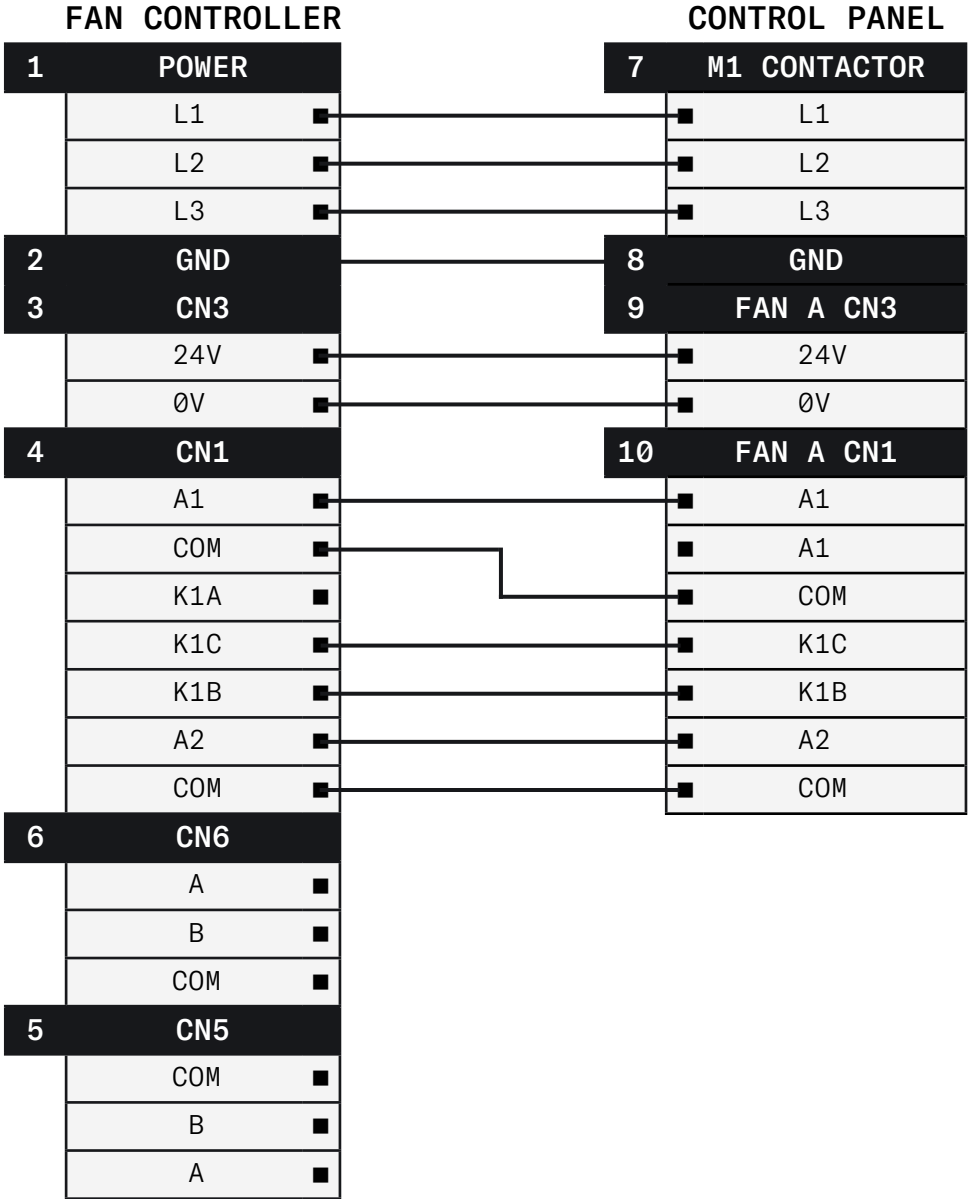

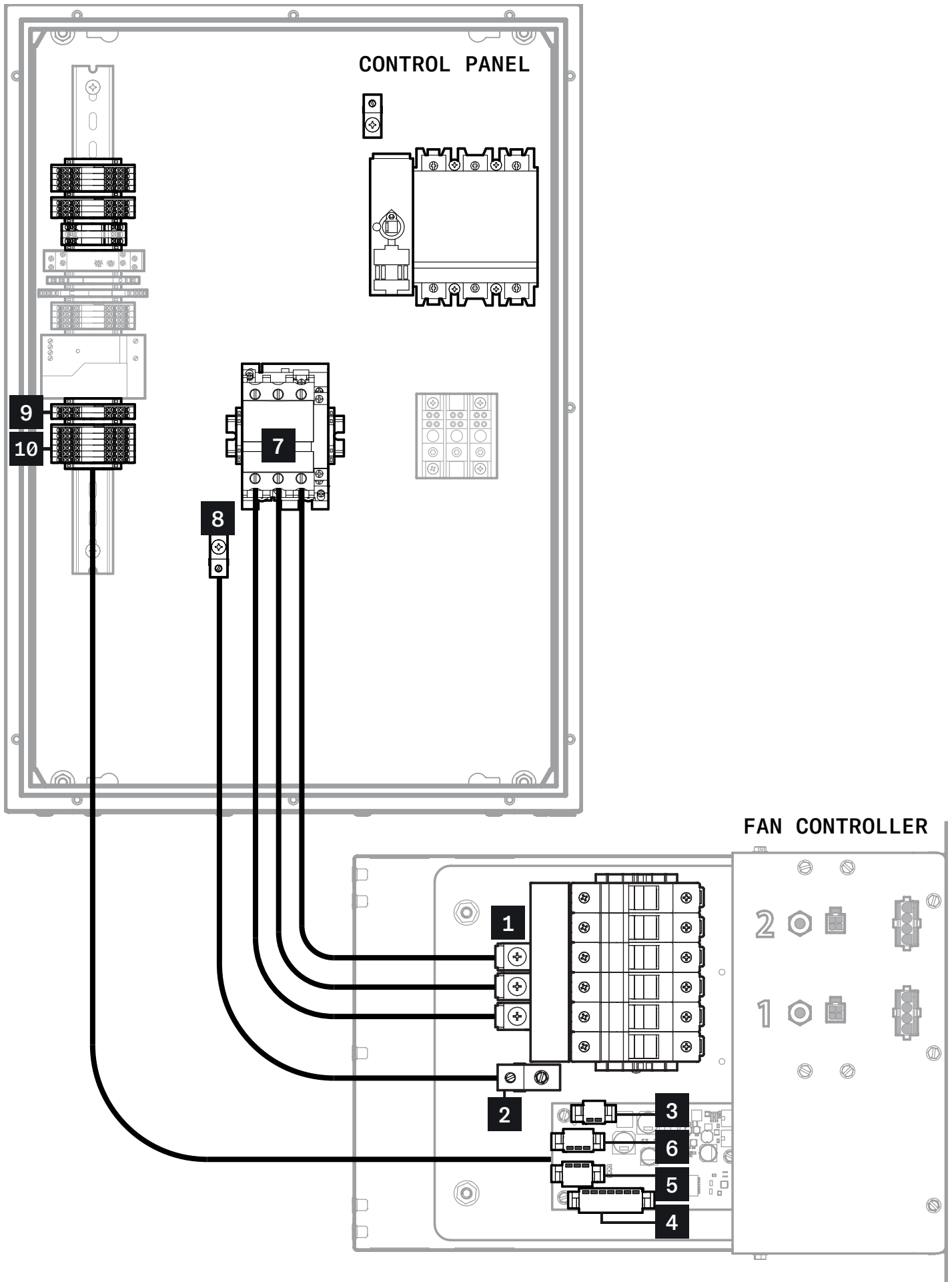

MULTIPLE FANS

When connecting to multiple Q-PAC Fans, the Control Panel will include a separate set of terminals and fuse blocks for each fan. Each set of terminals will be labeled with the corresponding fan label, A-D, as found on the Fan Controller.

FIRST FAN

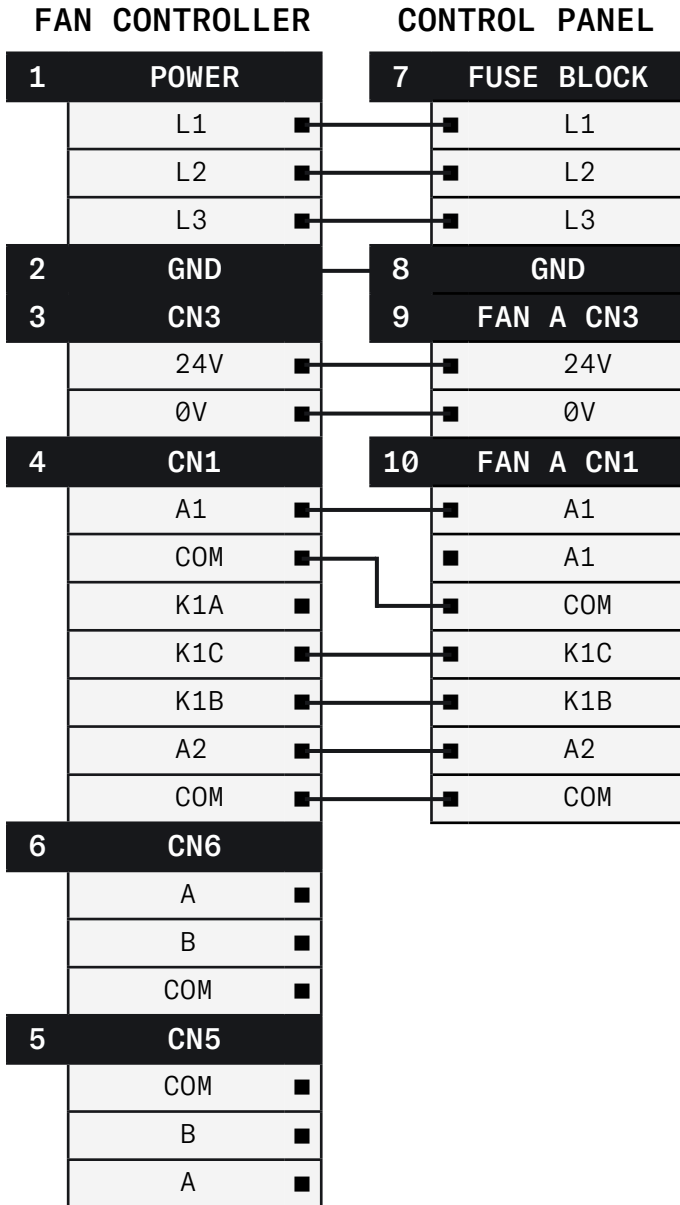

ALL OTHER FANS

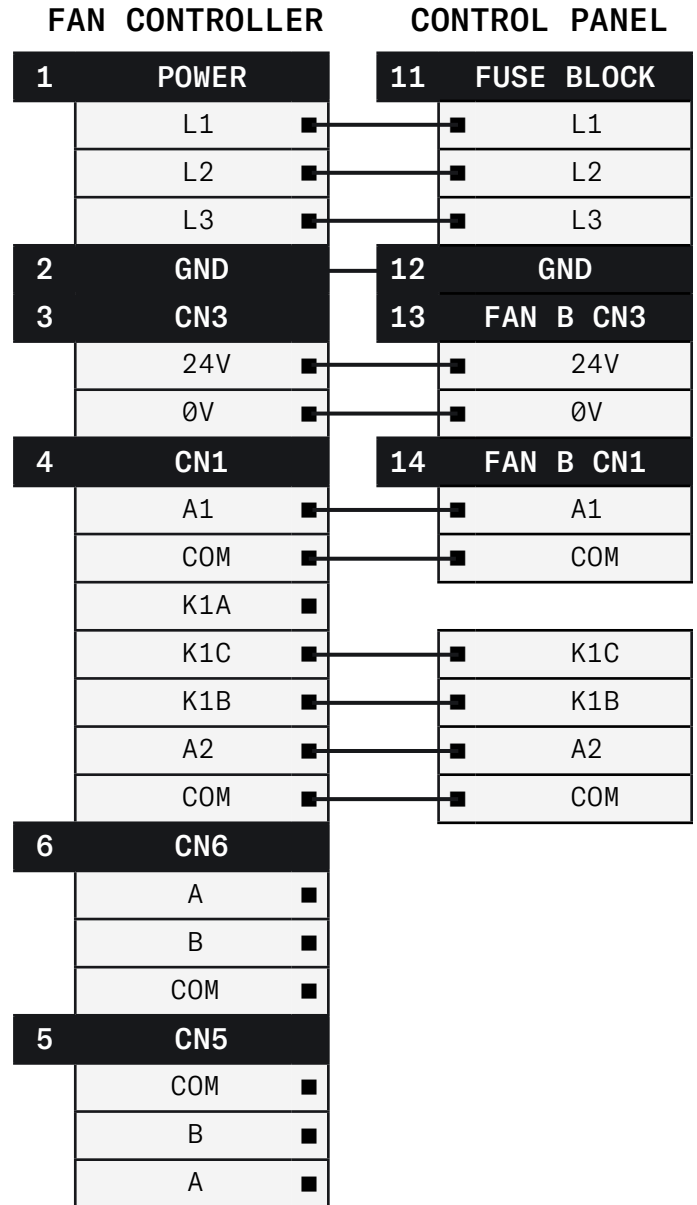

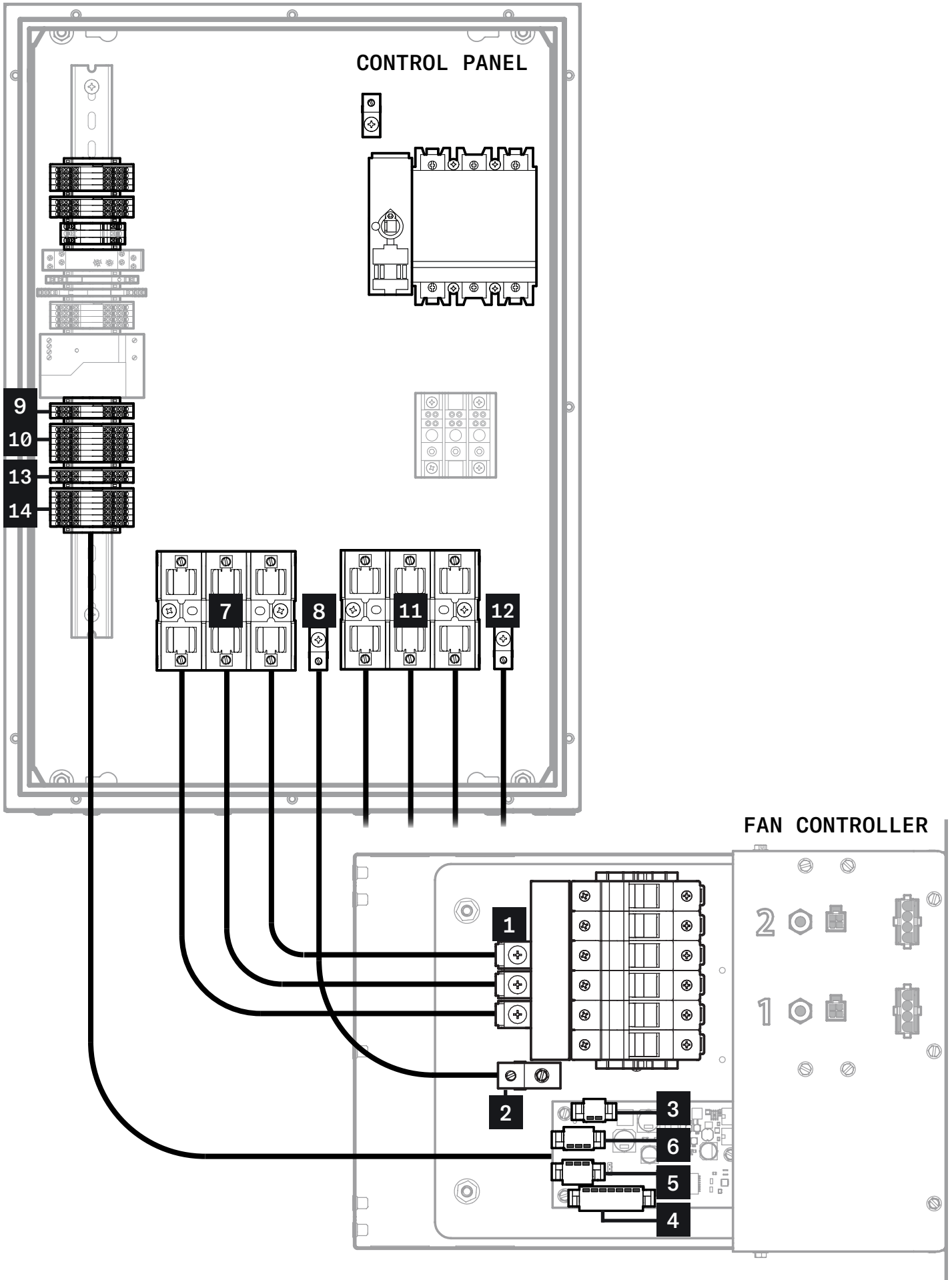

CONTROL PANEL WIRING

The Control Panel is designed as an external connection point for the fan system back to the BMS/BAS. Required and optional connection points are indicated below.

REQUIRED

1 TB 1			
■ AI1	Analog Input	Speed control, 0 - 10 VDC	Yes
■ COM	Common	Reference for AI1	Yes
■ NO1	NO Contact	Normally open circuit: System is in fault. Closed circuit: System is OK	
■ NO2	NO Contact		
2 TB 2			
■ 24VDC	Digital Output	Output for Digital Input controls (DI1, DI2), 24VDC	Yes
■ DI1	Digital Input	Safety Circuit	Yes
■ DI2	Digital Input	Start/Stop	Yes
3 TB 3			
■ +24	Supplemental power supply for field-supplied sensors and controls, 24VDC output, 0.75A maximum.		
■ -24			
4 INPUT POWER			
■ L1	3 Phase 208V or 480V input voltage for motors		Yes
■ L2	3 Phase 208V or 480V input voltage for motors		Yes
■ L3	3 Phase 208V or 480V input voltage for motors		Yes
5 GND			Yes

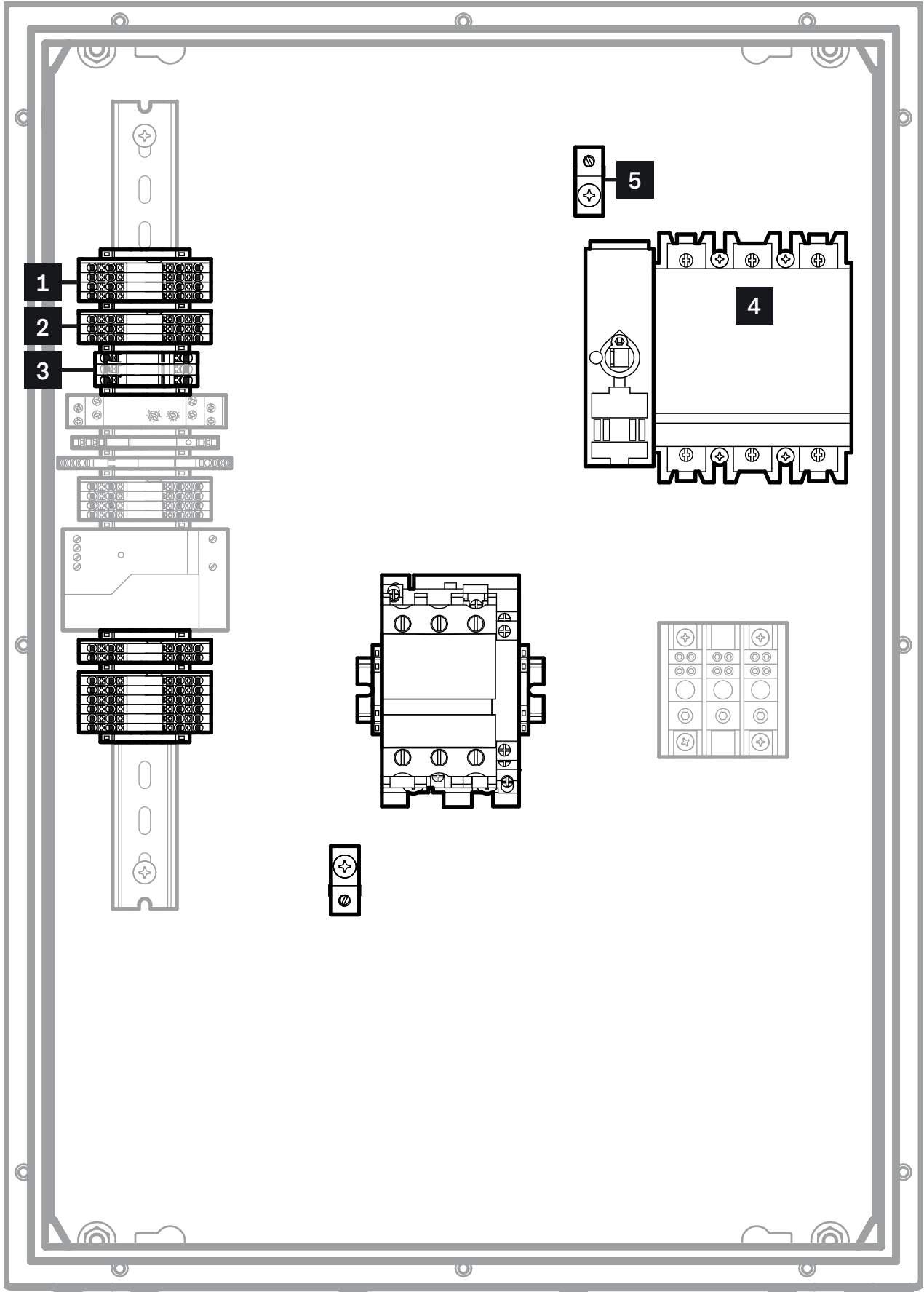

CONTROL PANEL (SINGLE FAN)

FAN CONTROLLER BOARD

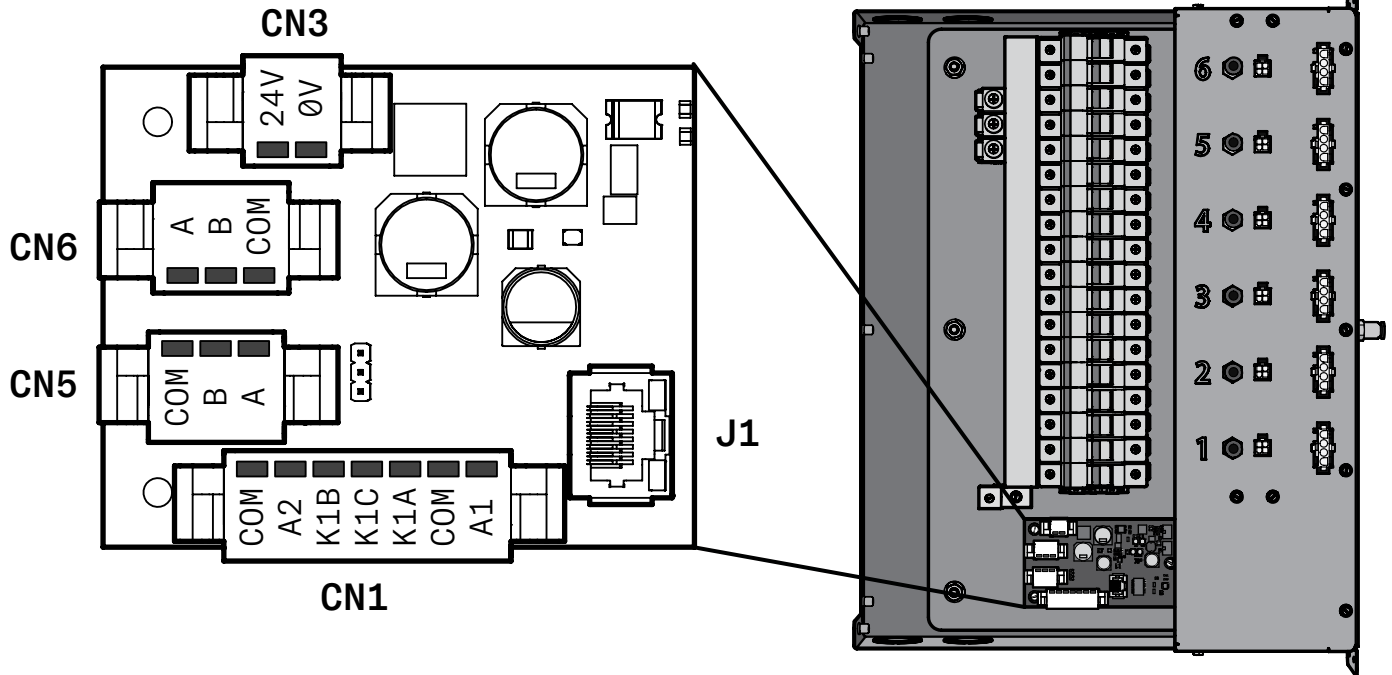

CN1: ANALOG INTERFACE

■ A1	0-10V signal proportional to the motor speed.
■ COM	0V reference for A1.
■ K1A	Normally closed (unpowered) contact of the alarm relay. When the controller receives power, the contact opens to indicate the absence of an alarm. If a fault occurs the contact will close again.
■ K1C	Common contact of the alarm relay. When a fault is present in the unit, this pin is connected to Alarm relay NC K1A and disconnected from Alarm relay NO K1B .
■ K1B	Normally open (unpowered) contact of the alarm relay. When the controller receives power, this contact closes to indicate the absence of an alarm. If a fault occurs the contact will open again.
■ A2	0V signal proportional to the calculated airflow.
■ COM	0V reference for A2.

CN3: INPUT POWER

■ 24V	24VDC/24VAC input voltage.
■ 0V	0VDC ground / 24VAC input voltage.

CN5: COMMUNICATION

■ A	Communications port +.
■ B	Communications port -.
■ GND	Communications port ground.

CN6: COMMUNICATION

■ A	Communications port +.
■ B	Communications port -.
■ GND	Communications port ground.

WIRE SIZING

When connecting the Q-PAC Fan to the Control Panel or other system components, it is recommended to use the following wire sizes:

CONTROL PANEL

208/480 VAC SUPPLY

Conductor size – determined by NEC – and Control Panel FLC, as listed on the Control Panel Nameplate (**Page 12**).

CONTROLS

- 24 VDC (+/- 10%) 500 mA OR 24 VAC (+/- 10%) 500 mA to **TB2 24V**
- 0-10 VDC 1 mA to **TB1 AI1, AI2, and AO1**

FAN CONTROLLER

208/480 VAC SUPPLY

Conductor size determined by NEC and Fan Controller MCA, as listed on the Fan Controller Nameplate (**Page 12**).

CONTROLS

- Min 24 AWG (CU) to **CN1** and **CN3**
- Min 24 AWG (CU) Shielded Twisted Pair to **CN5** and **CN6**

ELECTRICAL CHARACTERISTICS

The Fan Controller has two separate circuits: low voltage and high voltage. The low voltage circuit supplies power to the internal boards of the Fan Controller while the high voltage circuit supplies power to the motors of the Q-PAC Fan. The electrical characteristics of each are given below:

LOW VOLTAGE CIRCUIT

INPUT POWER (CN3)

NOMINAL INPUT VOLTAGE	24VDC or 24VAC
MAXIMUM INPUT VOLTAGE ¹	63VDC or 44VAC
FLA	500mA
MOCP	1A

¹ When a voltage higher than 40VDC or 28.3VAC is applied through CN3, the overvoltage protection circuit disconnects the input of the power supply block to prevent damage. The circuit automatically resets when the protection fuse returns to its operation temperature range.

ANALOG INPUTS (CN1)

SPEED MODULATION INPUT - VOLTAGE RANGE	24VDC or 24VAC
SPEED MODULATION INPUT - INPUT RESISTANCE	100Kohm
SPEED MODULATION INPUT - MAXIMUM VOLTAGE	40VDC

ANALOG OUTPUTS (CN1)

AIRFLOW ANALOG OUTPUT - VOLTAGE RANGE	0 - 10V
---------------------------------------	---------

RELAY OUTPUTS (CN1)

ALARM RELAY CONTACTS RATED LOAD ²	0.5A @ 125VAC or 2A @ 30VDC
MAXIMUM OPERATING VOLTAGE	125VAC or 125 VDC
MAXIMUM SWITCHING CAPACITY	62.5VA, 60W

² Resistive load

HIGH VOLTAGE CIRCUIT

The high voltage circuit characteristics will vary with the motor and motor quantity of the Q-PAC Fan. This information is therefore given on the **Fan Controller Nameplate** as shown below. The table below provides an example of the high voltage circuit characteristics.

Q-PAC		RECOGNIZED COMPONENT	Q-PAC Fan Conforms to UL 60335-2-40:2022 Ed.4
(904) 863-5300 SUPPORT@Q-PAC.COM 4010 DEERPARK BLVD ELKTON, FL 32033		 Intertek 4010006	Fan Controller Certified to UL 60730-2-15:2019 Ed.3
			US Pat. Nos. 11.852.151 11.375.085
SO#:		9230	
TAG:	7999 (K752)	AHU-99-2 SF	
MODEL:		1-9-1-2-1-1700076	
SERIAL#:		23H9999	
MFG:		MM/DD/YYYY	
MODBUS ADDR:		017	
POWER:		480V 3~ 60Hz	— A
SCCR:	10kA RMS SYM AT 600 V MAX		
MTR FLA:		7.86 A	— B
MCA:		72.70 A	— C
MOCP:		80.00 A	— D
<u>USE 15 AMP CLASS CC 600V FUSES</u>			

INPUT POWER

A	NOMINAL INPUT VOLTAGE	480V / 3~ / 60 Hz
	MAXIMUM INPUT VOLTAGE	600VAC
B	FLA PER MOTOR	7.86 A
C	MCA	72.70 A
D	MOCP	80.00 A

TORQUE TIGHTENING REQUIREMENTS

BOLTED BUS JOINTS

SIZE	TORQUE (lb-ft)	TORQUE WITH BELLEVILLE WASHER (lb-ft)
1/4 in	4	-
5/16 in	9	-
3/8 in	14	14
1/2 in	39	35
5/8 in	80	45

SLOTTED HEAD SCREWS

SIZE	AWG / MCM	SLOT WIDTH	SLOT LENGTH	TORQUE (lb-ft)
#4 - #8	22 - 8	< 0.47 in	< 1/4 in	7
			1 / 4 in	9
		> 0.47 in	< 5/32 in	9
			5/32 - 1/4 in	12
			9/32 in	15
			> 9/32 in	20
#10 and Larger	18 - 10	< 0.47 in	< 1/4 in	20
	8			25
	6 - 3	> 0.47 in	> 1/4 in	35
	2			40
	18 - 10			35
	6 - 4			45
3 - 1000		50		

HEX HEAD SCREWS

EXTERNAL HEX

AWG / MCM	TORQUE (lb-ft)
18 - 8	75
6 - 4	110
3 - 1	150
1/0 - 2/0	180
3/0 - 4/0	250
250 - 350	325
400 - 750	375
800 - 1000	500
> 1000	600

INTERNAL HEX / SOCKET

SIZE	TORQUE (lb-in)
1/8 in	45
5/32 in	100
3/16 in	120
7/32 in	150
1/4 in	200
5/16 in	275
3/8 in	375
1/2 in	500
9/16 in	600

START-UP AND TESTING

BEFORE FIRST START-UP



Ensure the Q-PAC Fan has been fully assembled and installed per the **Q-PAC Fan Assembly Guide**. Do not attempt to wire the Control Panel, Q-PAC Fan Controller, or complete any electrical testing before assembly as been completed.

1. Ensure assembly and installation of the Q-PAC Fan(s) has been completed per the **Q-PAC Fan Assembly Guide**.
2. Secure the Control Panel to the wall or similar surface using the corner mounting tabs, following local building code requirements and ensuring suitable working clearance.
3. Complete all conduit and electrical connections per the **Wiring Diagram**. See **Pages 28-31** or the included order documents.
4. Ensure the **Safety Circuit** and **Start/Stop** are closed. If contractor has not already installed the **Safety Circuit** and **Start/Stop**, use a temporary jumper between **DI1** and **24VDC** and between **DI2** and **24VDC**.
5. Turn potentiometer to ZERO and HOA Switch to OFF.
6. Check that all electrical connections comply with the specifications on the **Fan Controller** and **Control Panel** nameplates.
7. Check all mounting bolts, plugs, and wiring connections to ensure they are secure. Refer to the **Wiring Guide (Pages 28-31)** and **Torque Requirements (Page 38 and 39)**.
8. Ensure all harnesses are secured to the fan frame, all cable ties are tight, and all plug connections are secure.
9. Rotate each impeller by hand to inspect for contact with the inlet cone. If contact is observed, refer to **Inlet Cone Alignment** instructions on **Page 44**. Contact may be present if any of the following are observed:
 - i. There is noticeable material transfer/residue on the inlet cone or other signs of scraping.
 - ii. When rotating the impeller, there is an audible rubbing or scraping sound.
 - iii. When rotating multiple impellers simultaneously, at even speeds, one impeller stops rotating considerably earlier than the other.
10. Remove all leftover installation materials and other foreign objects from the fan area and the rest of the air handler.
11. Ensure all personnel are out of reach of the impeller blades.

BUMP TEST



Ensure the test preparation as listed in **BEFORE FIRST START-UP** has been completed. Do not attempt to operate the Q-PAC Fan until all electrical connections have been verified.

1. Turn on the **Disconnect**.
2. Turn **HOA Switch** to **HAND**.
3. Turn **Potentiometer** slowly to **2**.
4. Check to see if the plug fan impellers are spinning. If not, check electrical connections. Ensure the **Safety Circuit** and **Start/Stop** are closed. If contractor has not already installed the **Safety Circuit** and **Start/Stop**, use a temporary jumper between **DI1** and **24VDC** and between **DI2** and **24VDC**.
5. Watch for any visual or audible signs that the plug fan impeller is making contact with the inlet cone. If found, refer to **Inlet Cone Alignment** instructions on **Page 44**.
6. Once rotation of the impellers is confirmed, observe the fan for quiet operation with low vibration. Strong vibration due to unbalanced operation or poor installation may result in motor or fan failure.
7. Turn off the **Disconnect**.

RUN TEST



Ensure the test preparation as listed in **BEFORE FIRST START-UP** and **BUMP TEST** have been completed. Do not attempt to operate the Q-PAC Fan until all electrical connections have been verified.

1. Turn on the **Disconnect**.
2. Turn **HOA Switch** to **AUTO** to operate the fan according to the motor speed signal (0-10VDC) applied to **A11**.
3. Check to see if the impellers are rotating. If not, turn off power to the fan and check the electrical connections in the Fan Controller and connected hardware. Check any included safety circuits or other protections and relays.
4. Once rotation of the impellers is confirmed, observe the fan for quiet operation with low vibration. Strong vibration due to unbalanced operation or poor installation may result in motor or fan failure.
5. Allow the fan to run for a minimum of five (5) minutes and ensure that it reaches steady-state operation—maintaining steady airflow for at least five (5) minutes with no alarms at the Control Panel.
6. Turn off the **Disconnect**.

MAINTENANCE

INLET CONE ALIGNMENT

Proper alignment of the inlet cone is important for optimal airflow and efficiency, but also to minimize vibration and noise and ensure motor and bearing life is maximized. Improper alignment may cause uneven air distribution across the plug fan blades. This can cause unbalanced aerodynamic forces which may appear as vibration, rattling, and other noise, but ultimately may result in added stress on the motor bearings. This may result in reduced motor life and premature failure, on top of reduced performance and increased power consumption over time.



Ensure power is disconnected to the fan before attempting inlet cone alignment or any other maintenance or service on the fan or components.

To align the plug fan inlet cone(s):

1. Identify which inlet cones are out of alignment. To identify inlet cones which are out of alignment, check for the following:
 - i. There is noticeable material transfer/residue on the inlet cone or other signs of scraping.
 - ii. When rotating the impeller, there is an audible rubbing or scraping sound.
 - iii. When rotating multiple impellers simultaneously, at even speeds, one impeller stops rotating considerably earlier than the other.
2. On the upstream side of the unit, loosen (but do not remove) the fasteners securing the inlet cone to the fan plate.
3. Adjust the position of the inlet cone and ensure there is no further contact with the impeller. It is recommended that all conditions of Step 1 are rechecked.
4. Tighten the inlet cone fasteners.
5. Repeat **Step 1** for the next plug fan impeller.

INLET CONE
FASTENERS

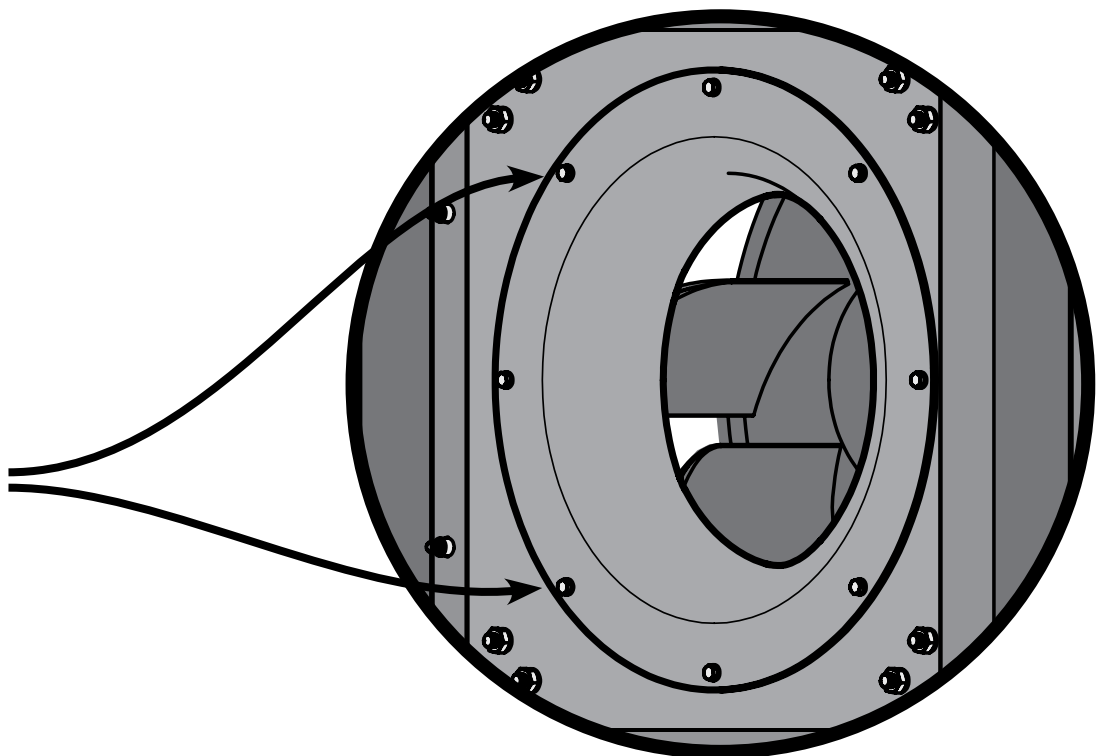

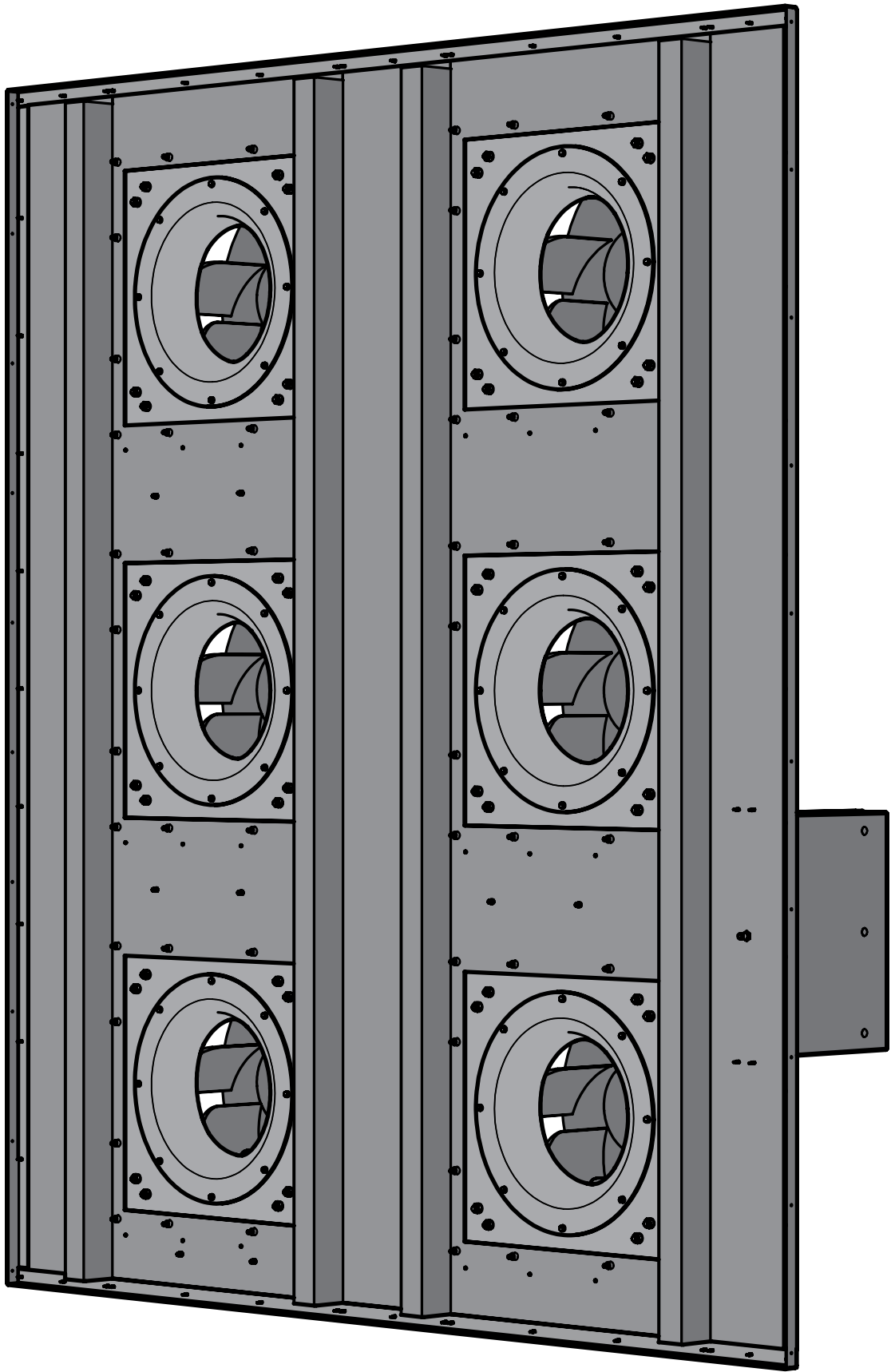

UPSTREAM VIEW

PLUG FAN REMOVAL

Over the operating life of the Q-PAC Fan(s), it may be necessary to replace **Plug Fans** due to damage or malfunction. The Q-PAC Fan is designed for **Plug Fans** to be swapped with the removal of a few bolts.



Ensure the Disconnect is OFF and there is no power to the fan before attempting inlet cone alignment or any other maintenance or service on the fan or components.

1. Disconnect the power and control plugs from the frame ledge by pinching the plug tab(s) and pulling the plug away.
2. Remove the pressure tubing from the nozzle by pressing downward on the plastic ring and pulling the tubing out.
3. Unfasten each bolt along the perimeter of the **Plug Fan** mounting plate. Ensure that the **Plug Fan** is properly braced when removing the final bolt to ensure that it does not fall forward. Save these bolts for installing the new **Plug Fan** or **Blank-Off Plate**.
4. Lift the **Plug Fan** upward, and away from the frame ledge.

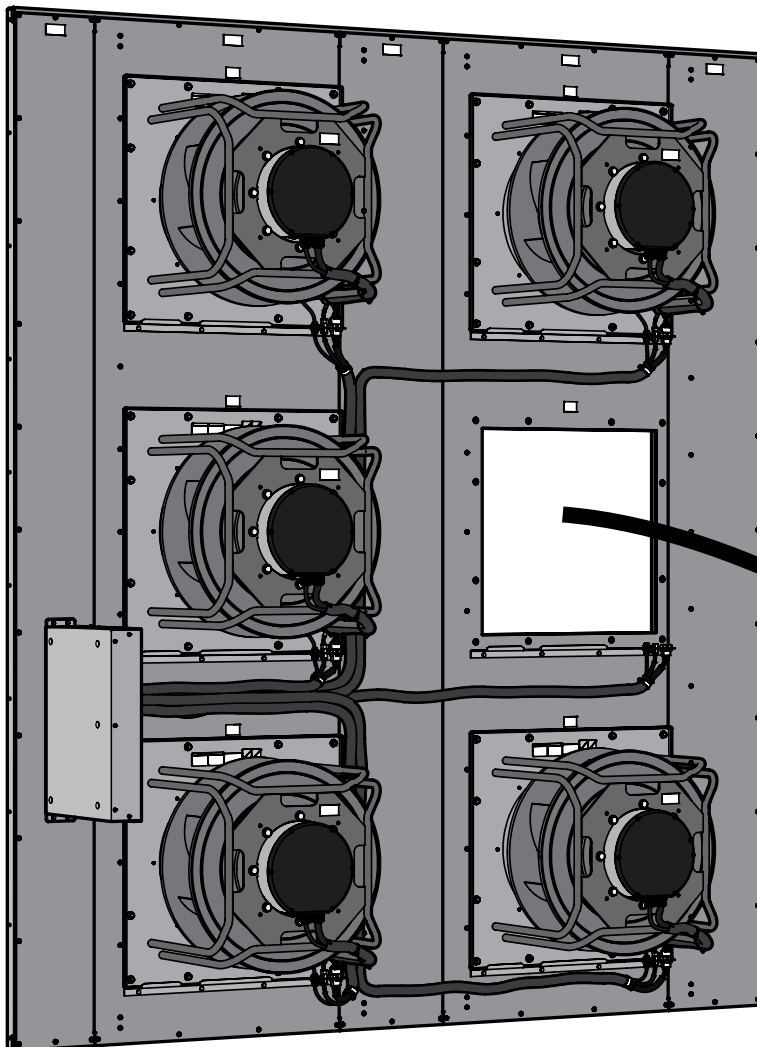
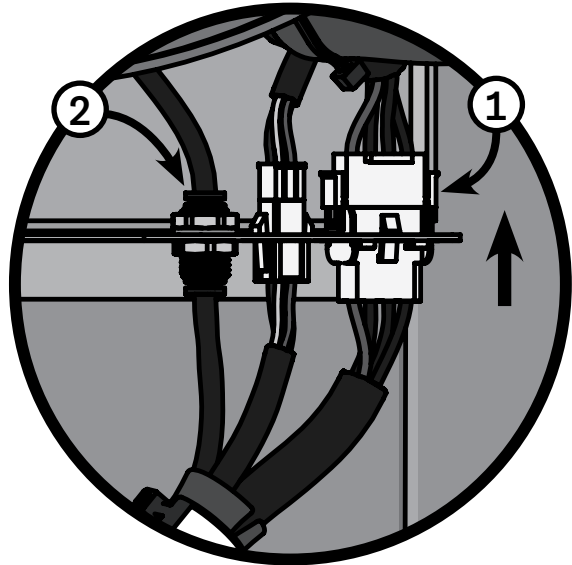

TOOLS & FASTENERS

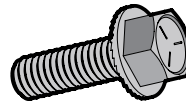

5/16"-18 x 1" or 1/2"-13-1
Hex Serrated Flange Bolt



5/16" or 1/2" Hex Head
Drive

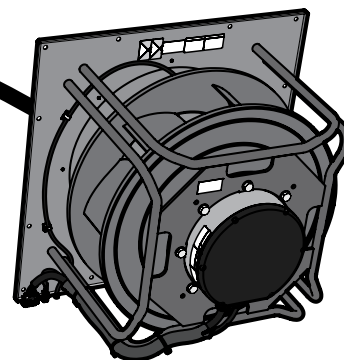

PLUG FAN OR BLANK-OFF PLATE INSTALLATION

If there is spare **Plug Fan (A)** available when removing a one after failure, it is recommended that it is installed in place of the old **Plug Fan**. If not, a **Blank-Off Plate (B)** can be installed instead to prevent backflow when operating until a replacement is available.



Ensure the Disconnect is OFF and there is no power to the fan before attempting inlet cone alignment or any other maintenance or service on the fan or components.

PLUG FAN INSTALLATION (A)

1. Lift the **Plug Fan** up and onto the open ledge. Brace the **Plug Fan** against the frame to ensure it does not fall forward.
2. With the **Plug Fan** braced, fasten the **Plug Fan** to the **Fan Frame**.
3. Reconnect the power and control plugs and insert the pressure tube into the nozzle of the ledge.
4. Check inlet connect alignment (**Page 44**) before returning the fan to service.

BLANK-OFF PLATE INSTALLATION (B)

1. Set the **Blank-Off Plate** onto the open ledge. Brace the **Blank-Off Plate** against the frame to ensure it does not fall forward.
2. With the **Blank-Off Plate** braced, fasten the to the **Fan Frame**. Set unused bolts aside for re-use when a replacement **Plug Fan** is received.

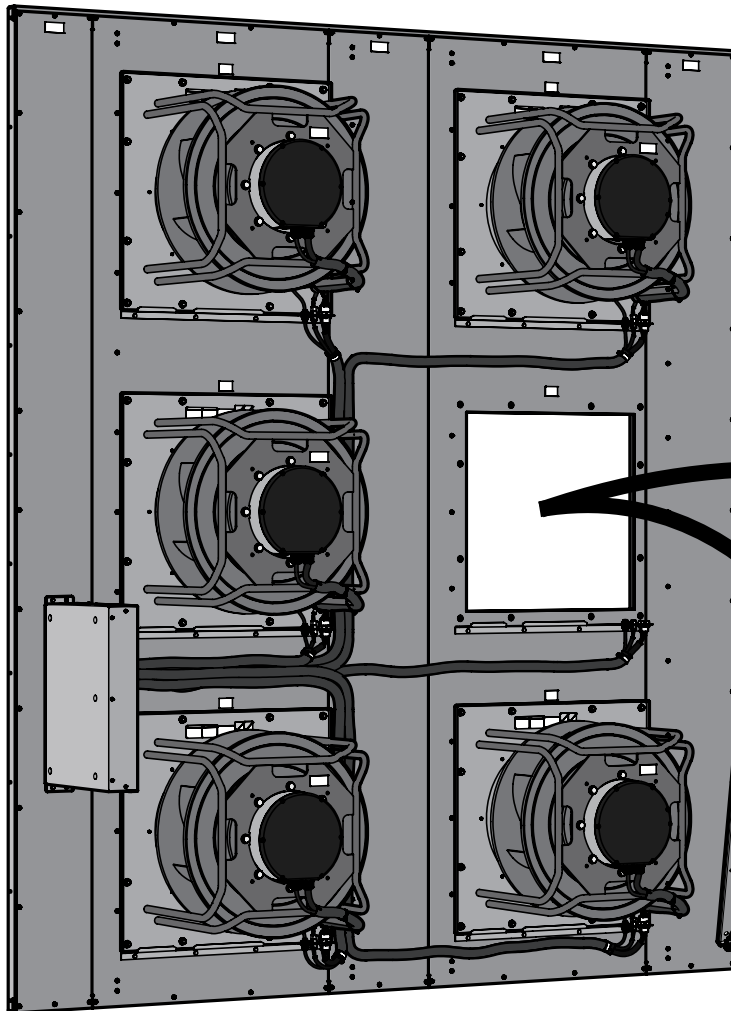

TOOLS & FASTENERS

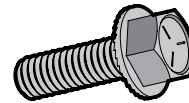

5/16"-18 x 1" or 1/2"-13-1
Hex Serrated Flange Bolt



5/16" or 1/2" Hex Head
Drive

Q-PAC

For assistance, questions, or troubleshooting, contact
Q-PAC Support at (904) 863-5300 or support@q-pac.com