

# CRX-3iA



Max. load capacity  
at wrist: 3kg



Max. reach  
(end of flange):  
692 mm

# FANUC

Robot			Max. load capacity at wrist (kg)	****Reach (mm)	Controlled axes	**Repeatability (mm)	Mechanical weight (kg)	Motion range (°)						*Maximum speed (°/s)		***Allowable Wrist Load			Protection		
Series	Version	Type						J1	J2	J3	J4	J5	J6	Collaborative Mode [mm/sec]	High Speed Mode [mm/sec]	J4 Moment/ Inertia	J5 Moment/ Inertia	J6 Moment/ Inertia	Input power source (VAC)	Body standard	Wrist & J3 arm
CRX	iA	3	3	692	6	±0.02	11	400	360	592	380	360	450	1200	2500	8.5/ 0.32	6.5/ 0.24	4/ 0.08			

● standard ○ on request - not available \* During short distance, it may not reach the maximum value stated. Please set motion speed according to risk assessment of system. \*\* Based on ISO9283 \*\*\*Nm/Kg.m<sup>2</sup> \*\*\*\*At the end of flange

CRX-3iA Standard model

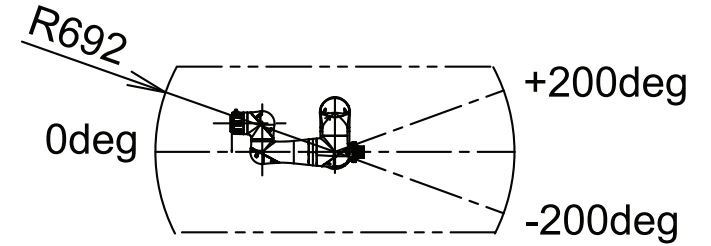

## END OF FLANGE

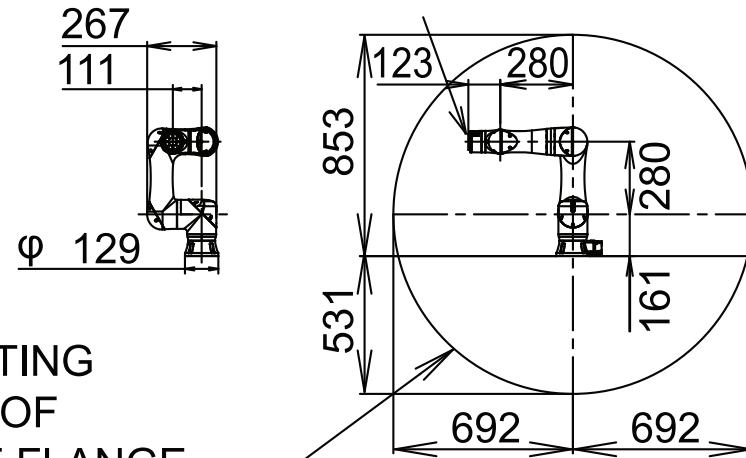

OPERATING SPACE OF END OF FLANGE (J4=+90 DEG)